



GAILTALBAHN



© Helmut Stattmann

18+ | 739 Teile | Schlieren 1735

Die Schlierenwagen der ÖBB 1. Klasse



© Gerfried Moll

Gattung	Ap
Nummer	17-35 000-019
Anzahl	20
Hersteller	SGP
Baujahr(e)	1970
Spurweite	1435 mm
vLänge über Puffer	23.700 m
Länge	23.400 m
Höhe	3.700 m
Drehzapfenabstand	17.600 m
Drehgestellachsstand	2.700 m
Höchstgeschwindigkeit	140 km/h
Bremse	Druckluftbremse & Handbremse
Kupplungstyp	Schraubenkupplung

Die Schlierenwagen der ÖBB



© Helmut Stattmann

Die Schweizerische Bundesbahnen (SBB) beschafften ab 1956 unter der Bezeichnung „Einheitswagen I“ eine neue Generation an 23,7 m langen Reisezugwagen. Neben 1. und 2. Klasse-Wagen wurden auch Speisewagen, Gepäckwagen und Steuerwagen gefertigt. Durch den Erfolg in der Schweiz wurden die Österreichischen Bundesbahnen (ÖBB) auf diese Wagen aufmerksam.

In der Folge bestellte die ÖBB 1963 bei den heimischen Firmen Simmering-Graz-Pauker (SGP) und Jenbacher Werken verschiedene Ausführungen von Waggons nach dem Vorbild der SBB Einheitswagen I. Statt Wagen aufwendig und langwierig selbst zu entwickeln, griffen die Hersteller auf Lizenzfertigungen zurück, die von den Herstellern Schweizerische Industriegesellschaft Neuhausen (SIG) und der Schweizerischen Waggonfabrik gewährt wurden.

Da letztere ihren Firmensitz in der Schweizer Stadt Schlieren hat, setzte sich in Österreich der Name „Schlierenwagen“ für diese Type durch. Zwischen 1965 und 1981 wurden insgesamt 800 Stück an

die ÖBB geliefert. In den ersten Jahren wurden die Wagen noch in Tannengrün mit weiß-aluminiumfarbigem Dach ausgeliefert. Ab 1975 erfolgte die Umstellung auf die Farbkombination Blutorange und Elfenbein. Die Wagen waren für 140 km/h zugelassen und konnten auch international für Fahrten in die Schweiz, nach Deutschland und nach Italien eingesetzt werden.

Für die ÖBB wurden 1. Klasse-Wagen, gemischte 1. und 2. Klasse-Wagen, 2. Klasse-Wagen, 2. Klasse-Wagen mit Gepäckabteil und 2. Klasse-Wagen mit Buffet gefertigt. Die 1. Klasse-Waggons verfügten wegen dem komfortableren vergrößerten Sitzabstand über weniger Sitzreihen als die Waggons der 2. Klasse, was auch an der Fensteranzahl erkennbar ist. In den folgenden Jahren entstanden durch Umbauten weitere Subtypen, u. A. auch für den Fahrradtransport.

Die Schlierenwagen der ÖBB



© Helmut Stattmann

Nach der Auslieferung wurden die damals neuen Wagen nur im hochwertigen internationalen Fernverkehr eingesetzt. Sukzessive verlagerte sich der Einsatz im Lauf der Jahre zunächst in den innerösterreichischen D- und Eilzugverkehr, bis die Wagen schlussendlich im Regionalverkehr eingesetzt wurden.

Schlierenwagen wurden von ÖBB am Ende ihrer Einsatzzeit auch ins Ausland abgegeben, u. a. in den Kosovo und nach Ungarn (GySEV und MÁV). Der größte Teil wurde jedoch verschrottet.

Derzeit sind Schlierenwagen in Österreich noch bei der Österreichischen Gesellschaft für Eisenbahngeschichte (ÖGEG), dem Verein der Eisenbahnfreunde Lienz (EBFL), der Regiobahn und dem Verein Neue Landesbahn vorhanden und kommen im Ausflugs- und Sonderverkehr zum Einsatz.

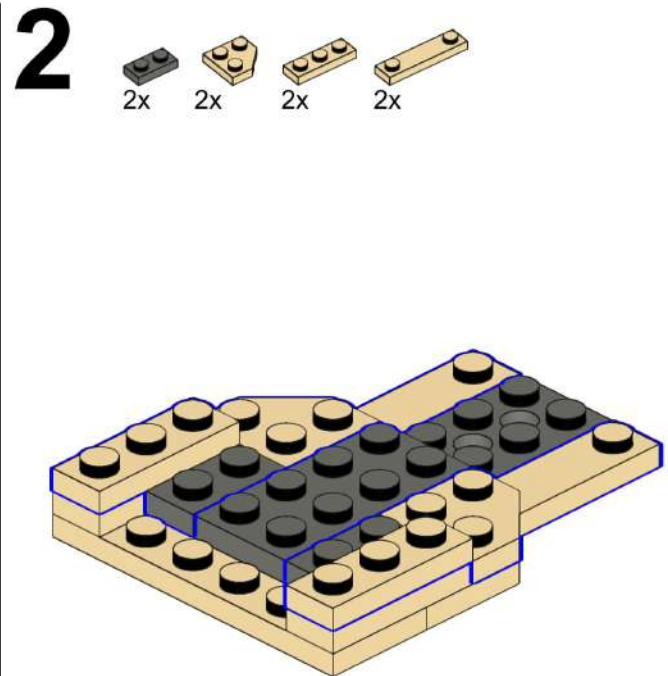
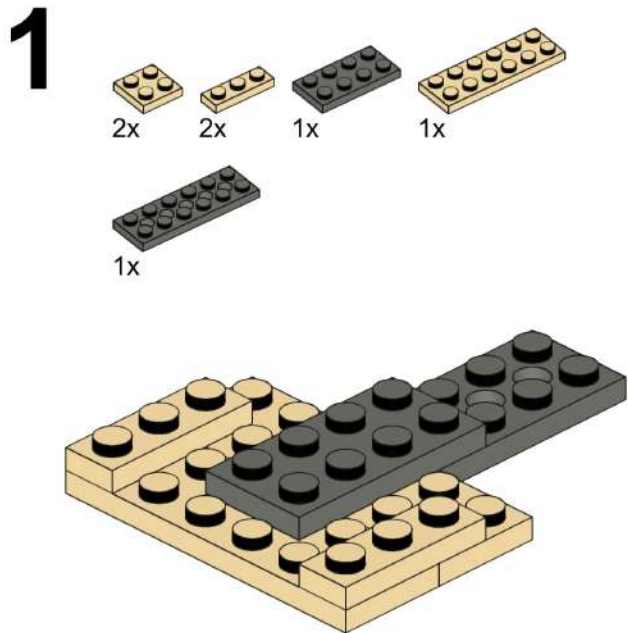

3

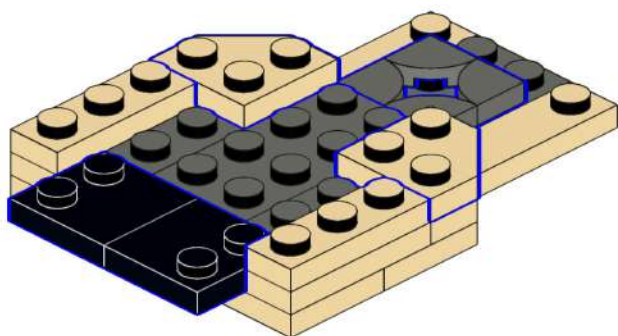
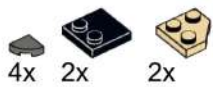

4

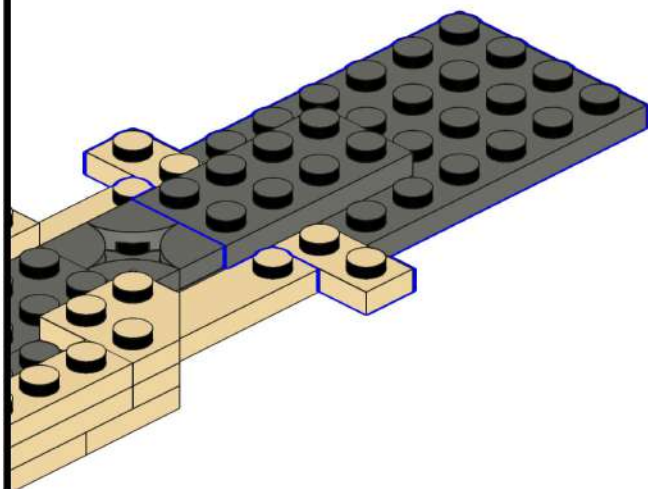
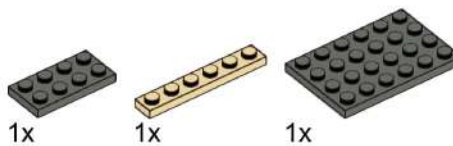

5

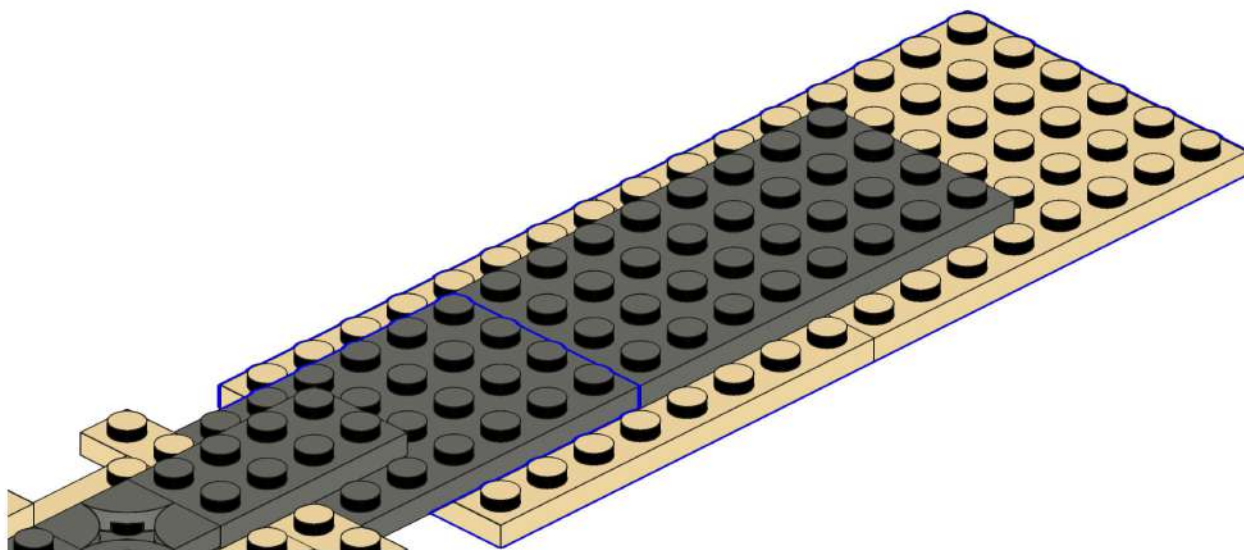
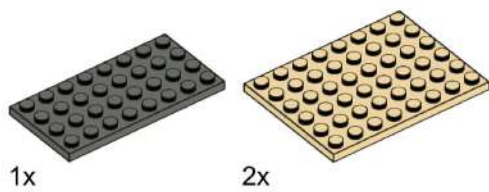

6

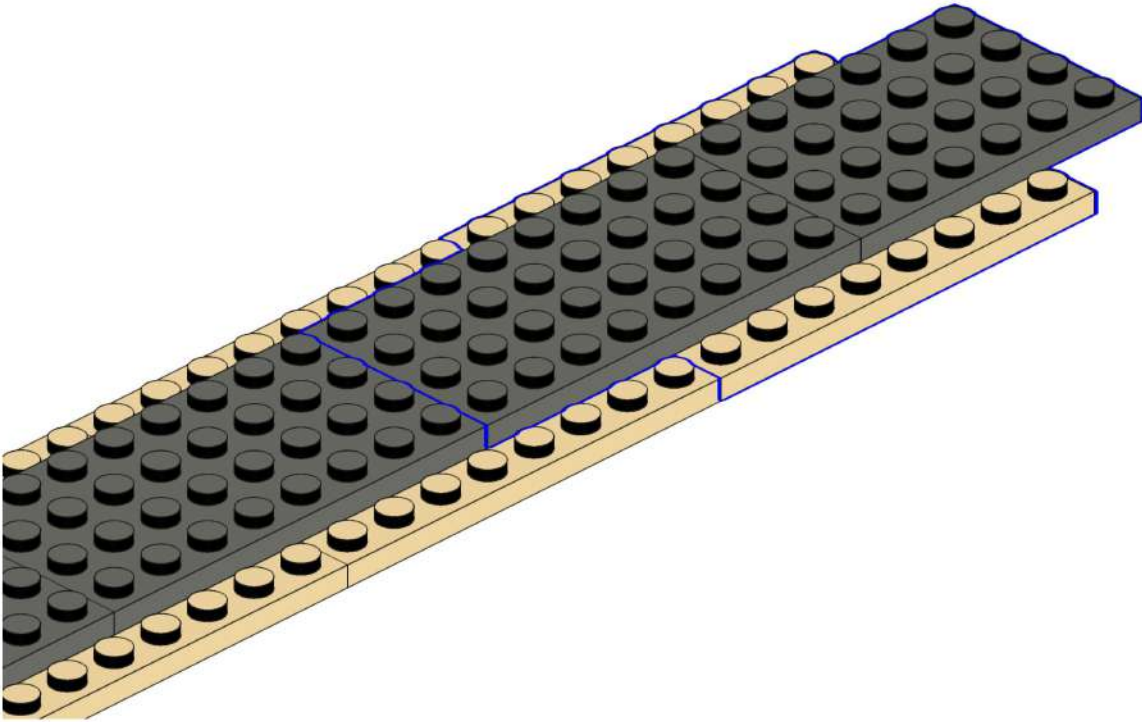

7

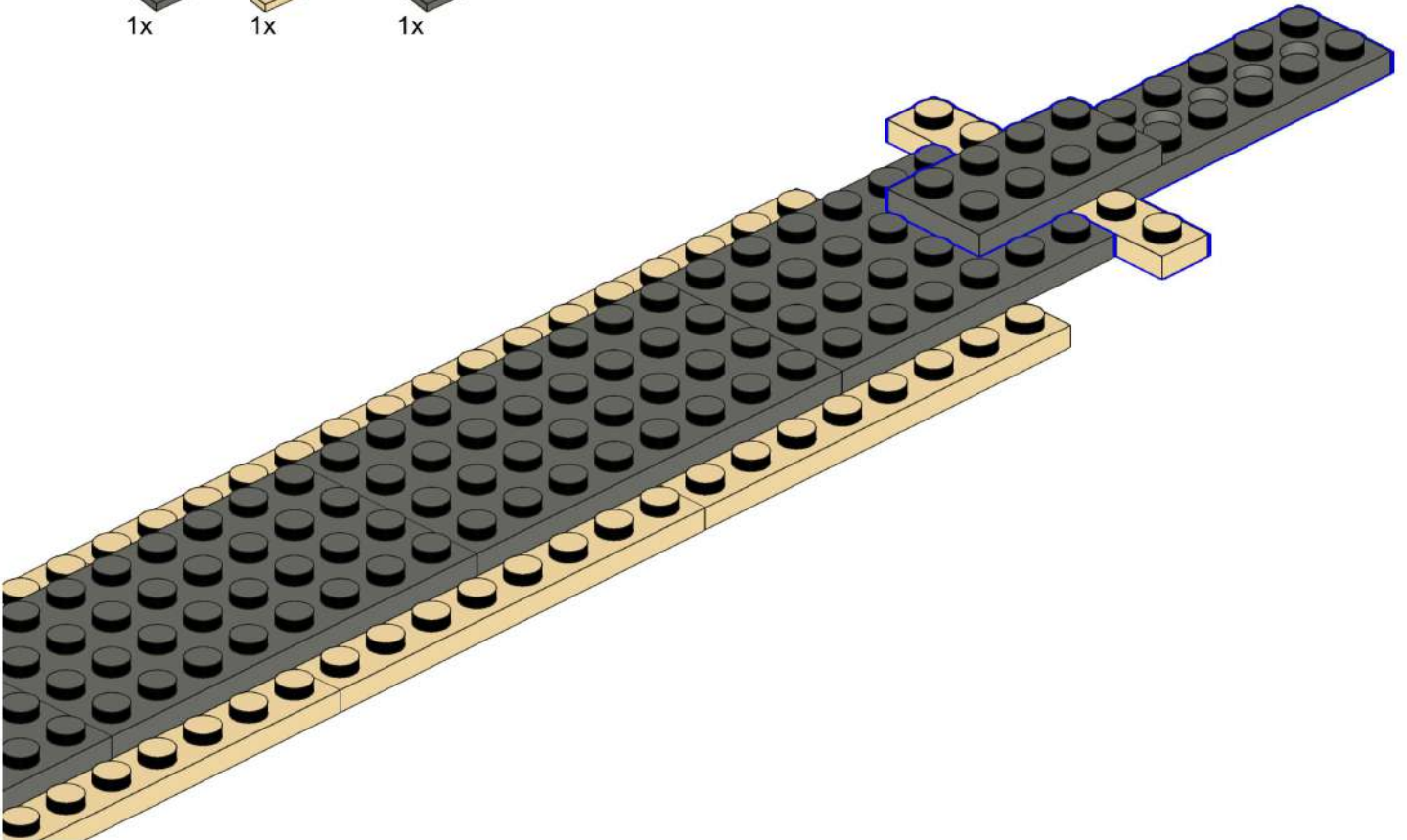
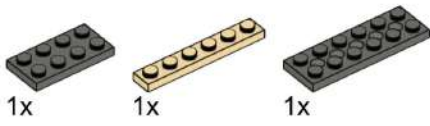

7



1x

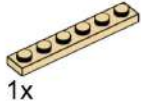

1x



1x

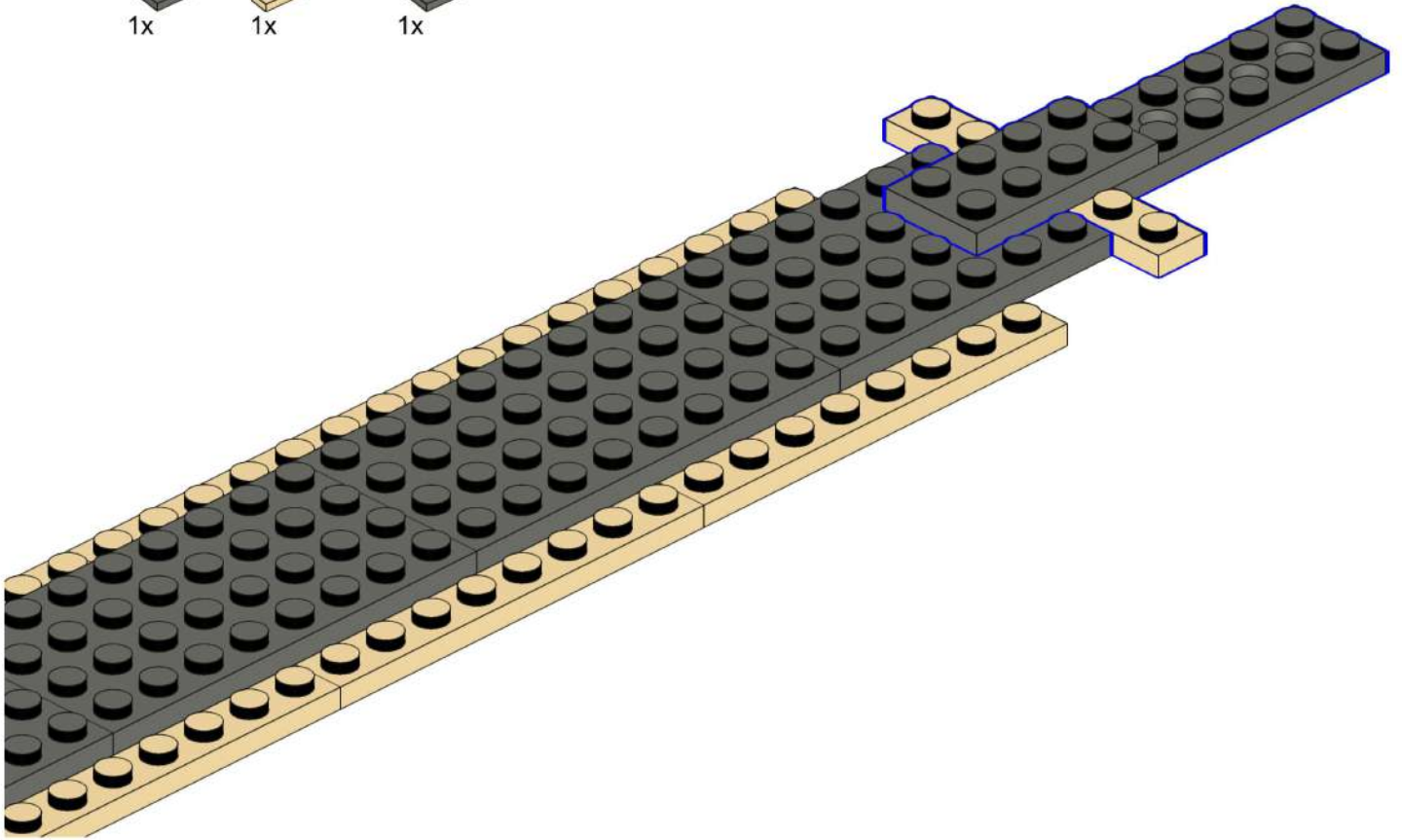

8



4x



2x

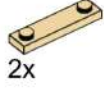

2x

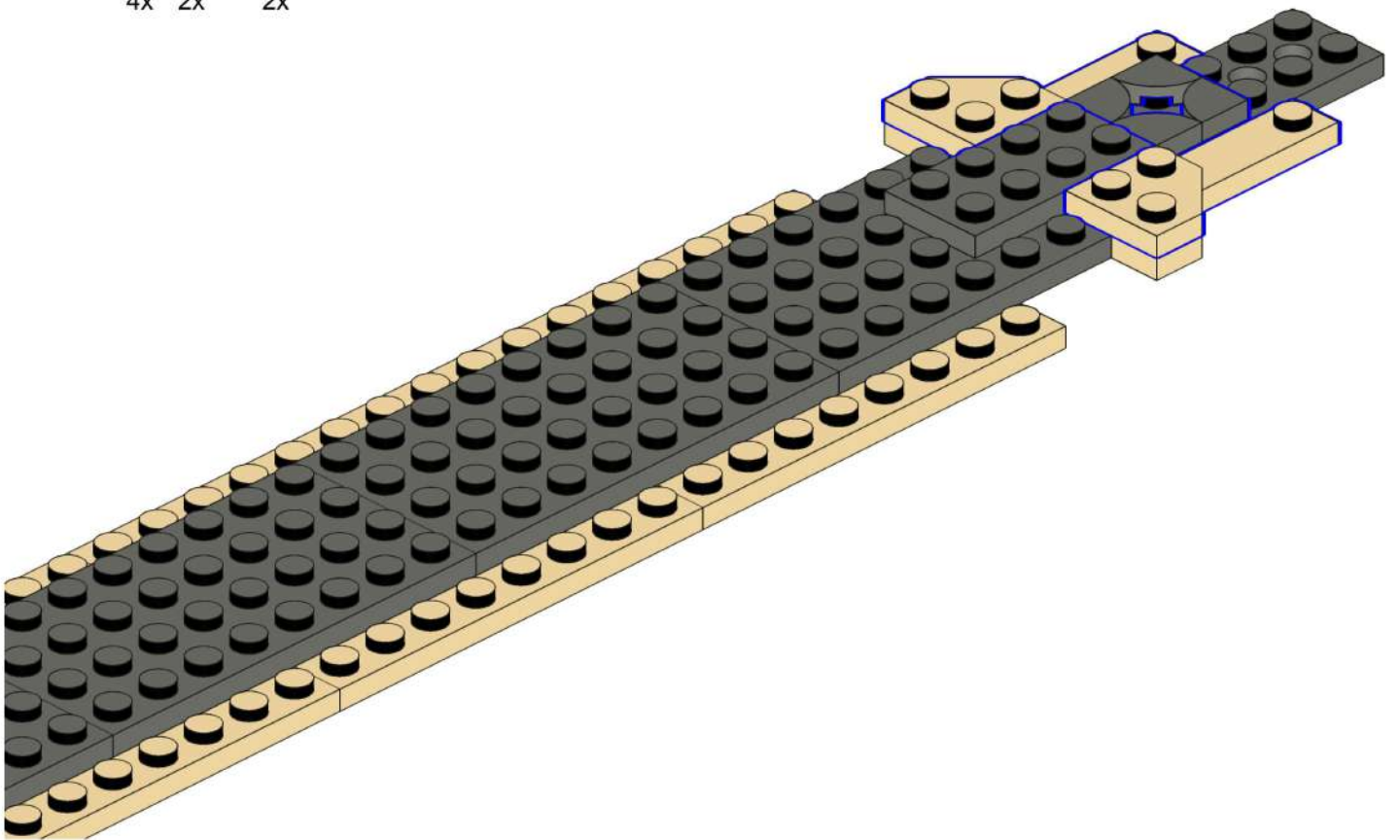

9

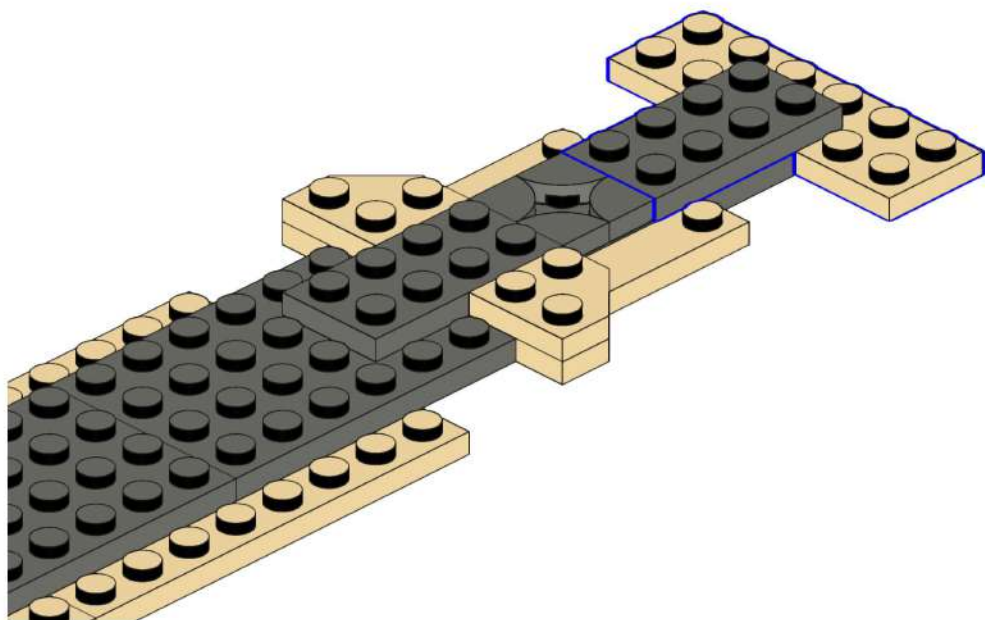
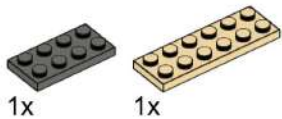

10

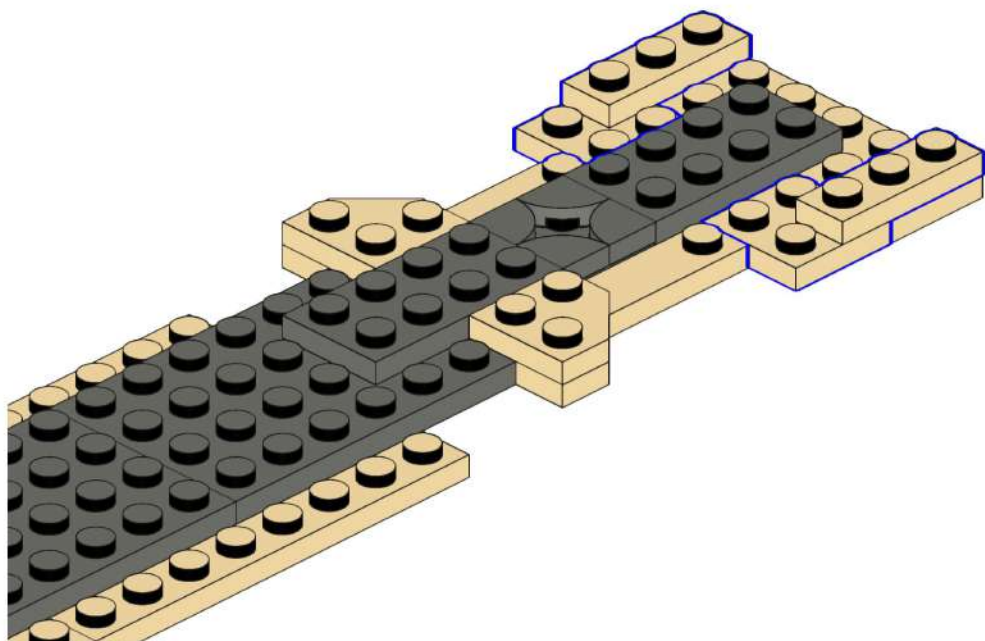
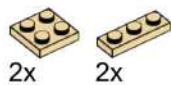

11

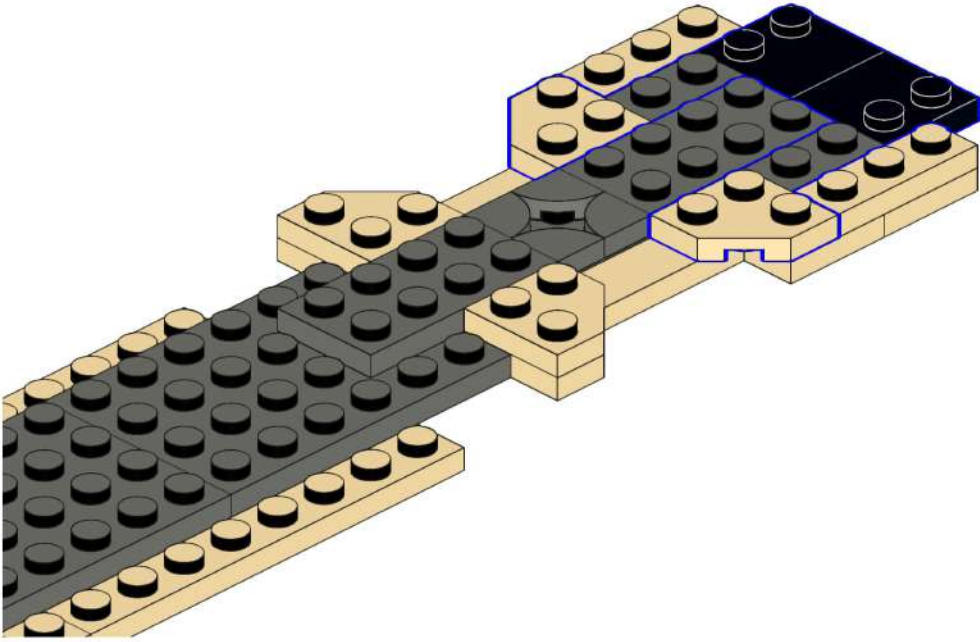

12

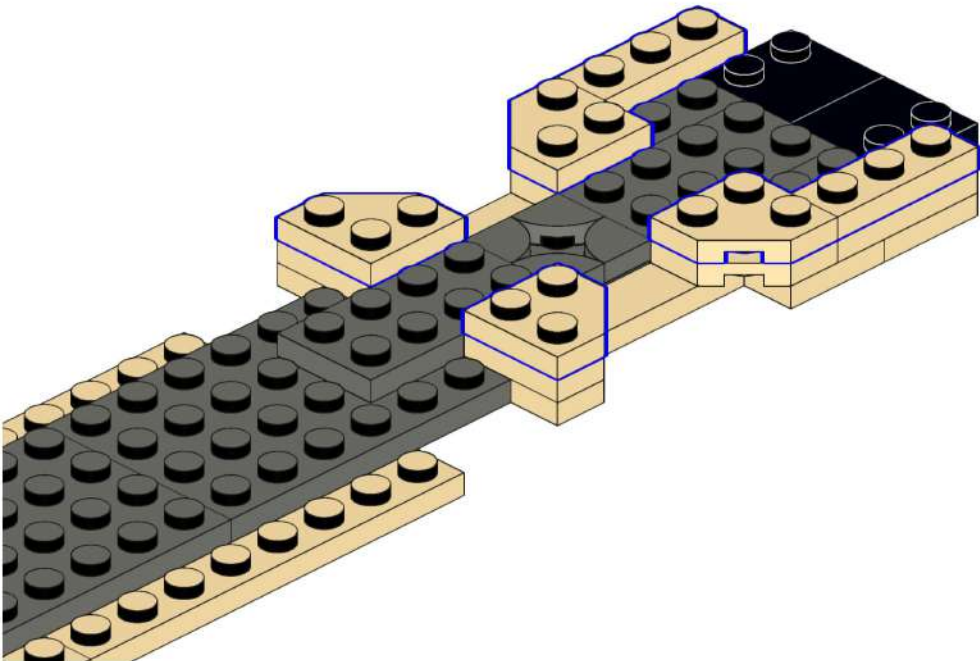
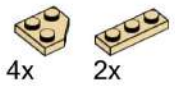

13



2x

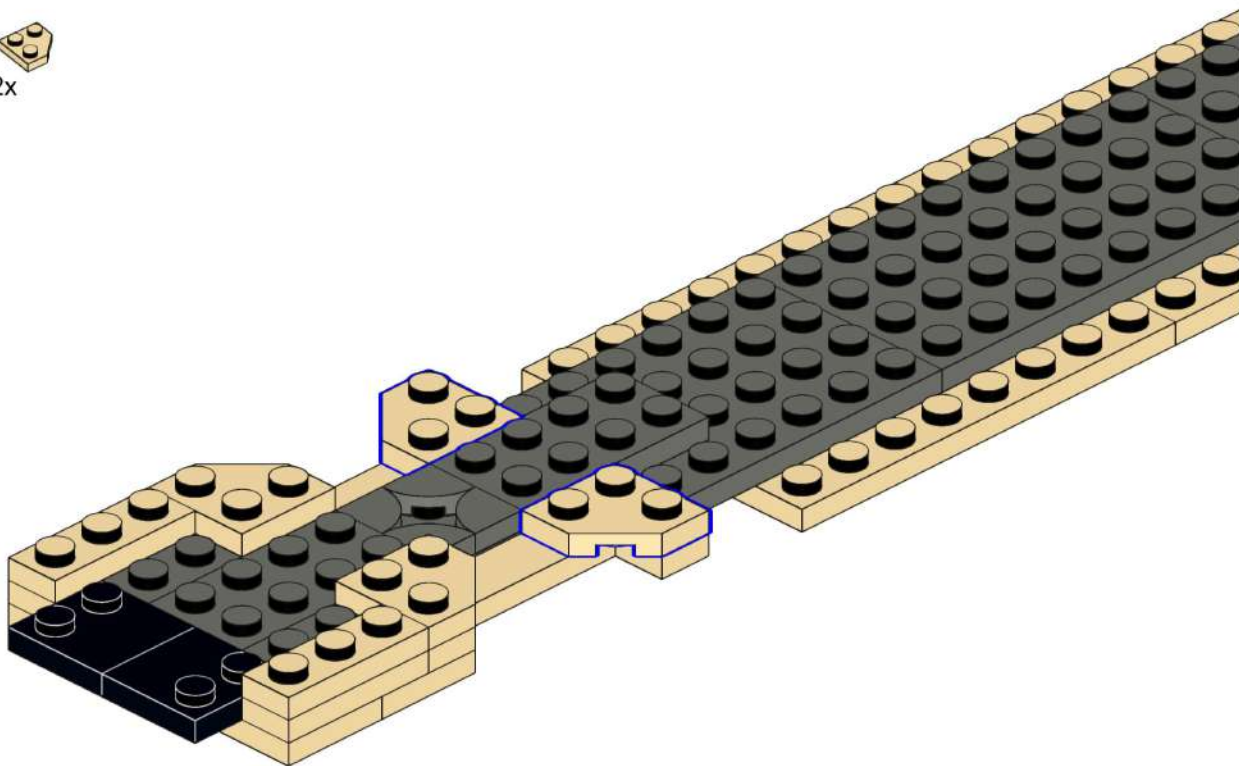

14



2x

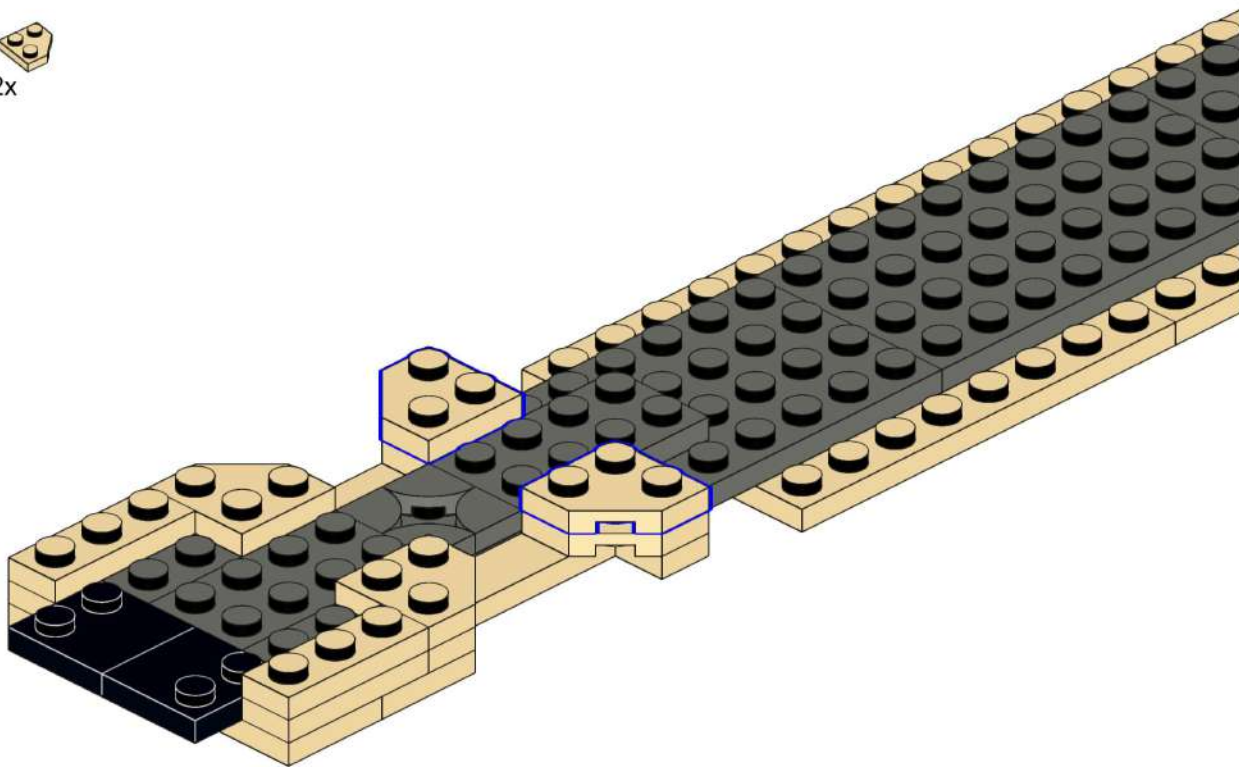

15

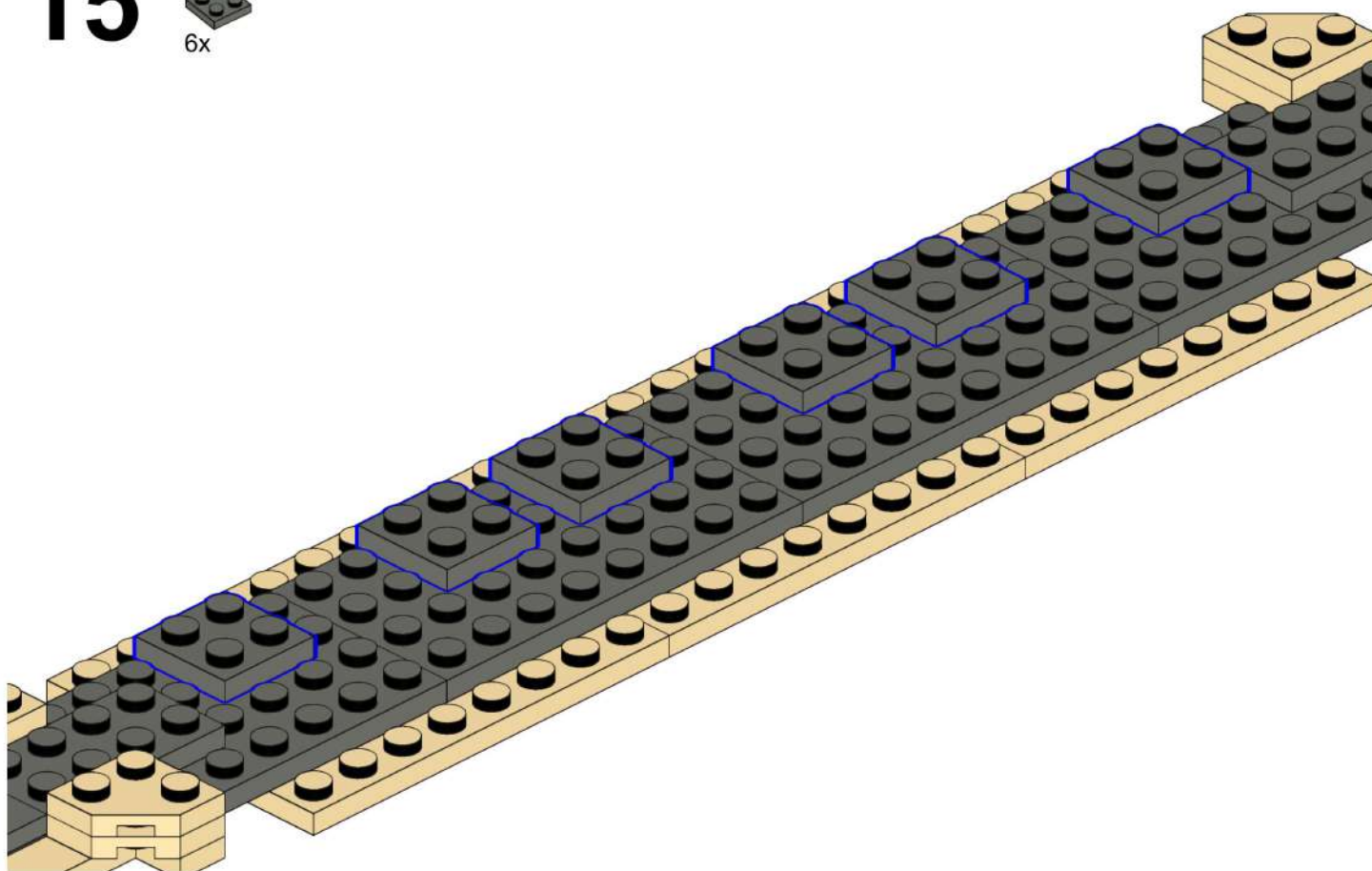

16

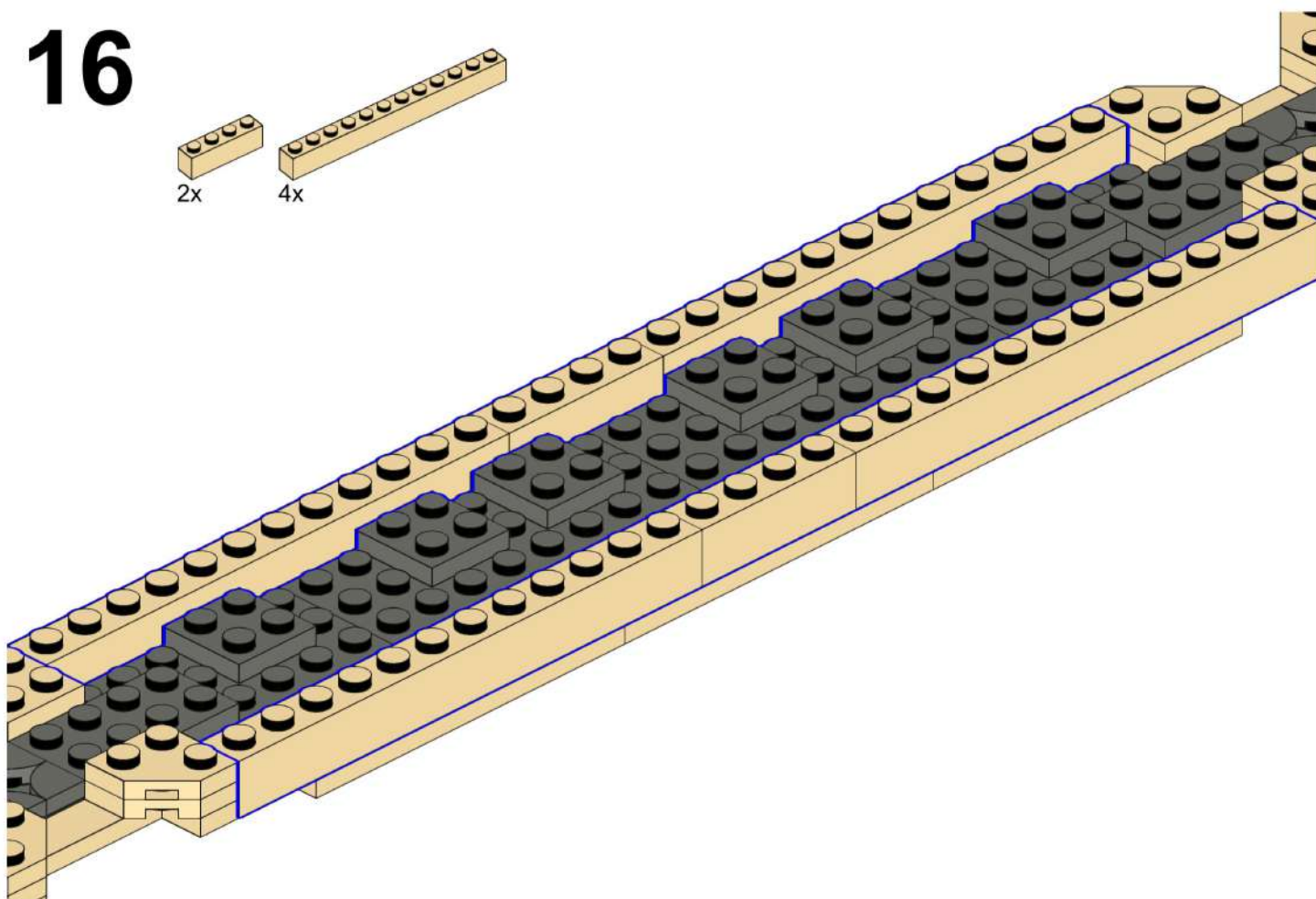
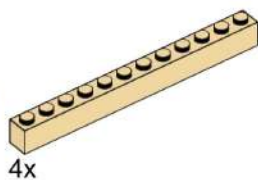
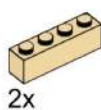

17

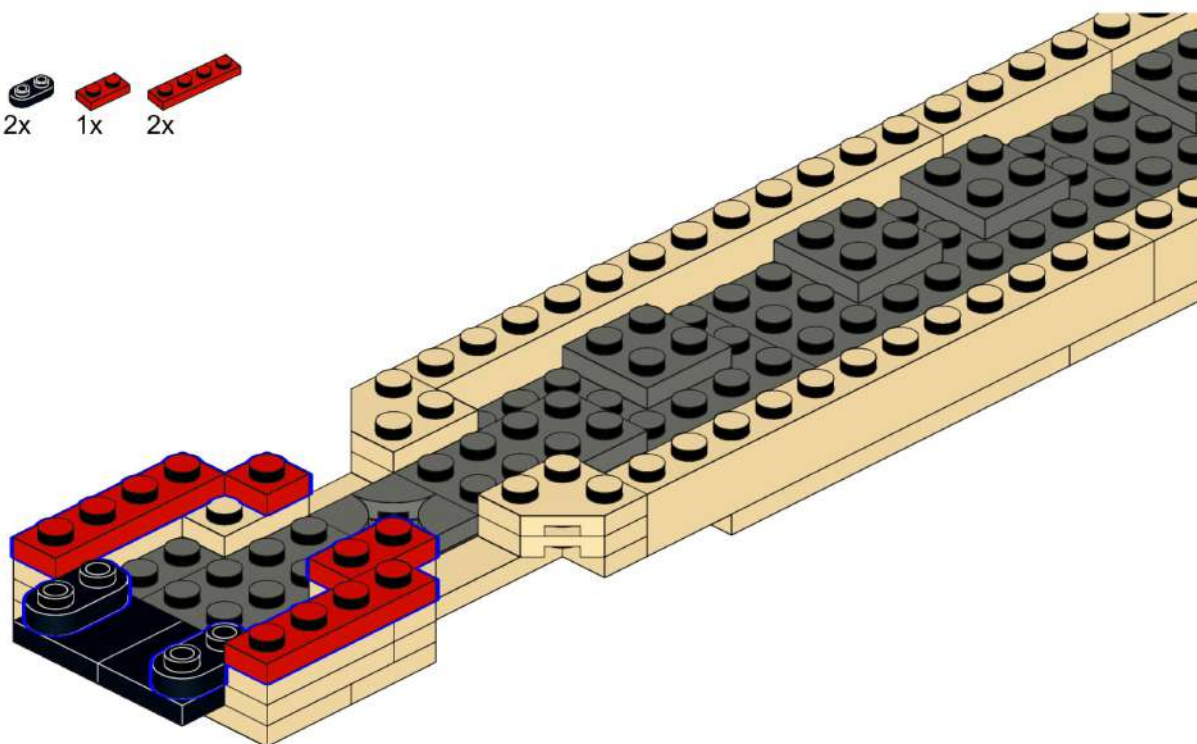

18

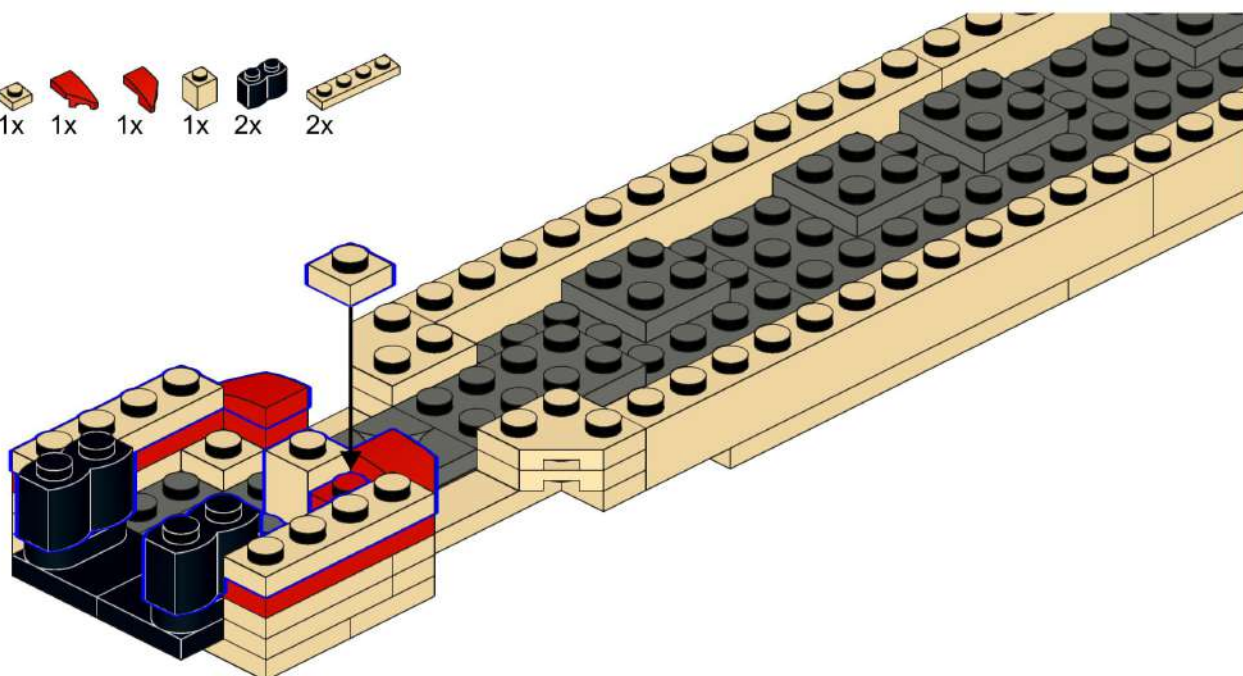
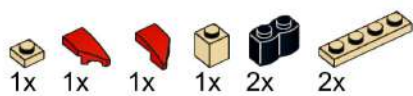

19

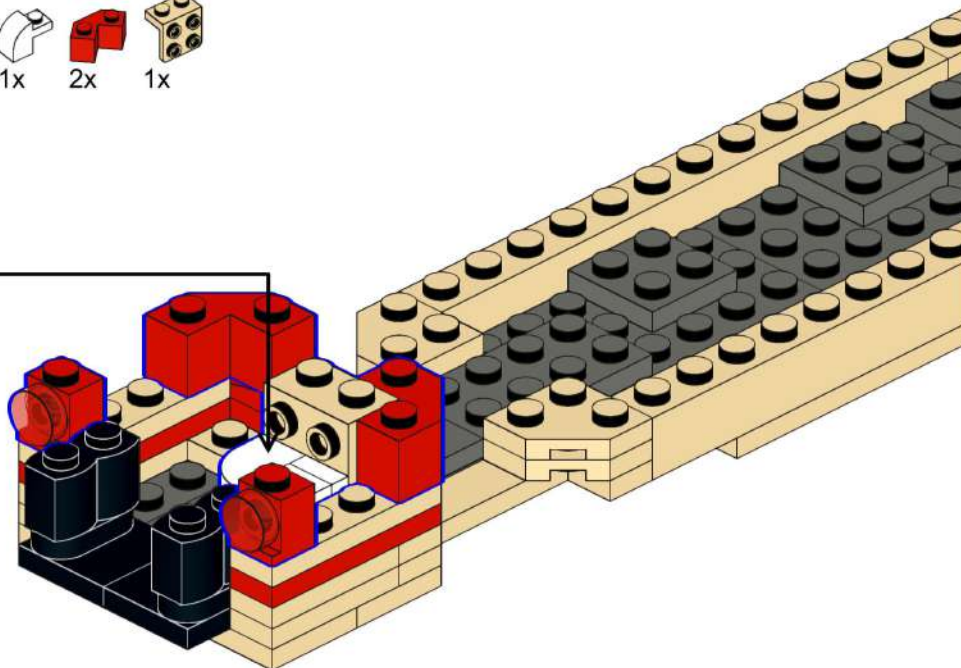
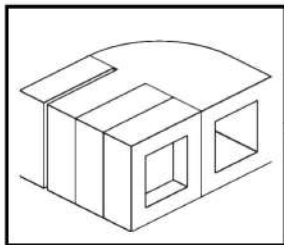
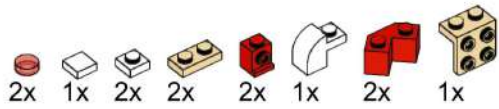

20

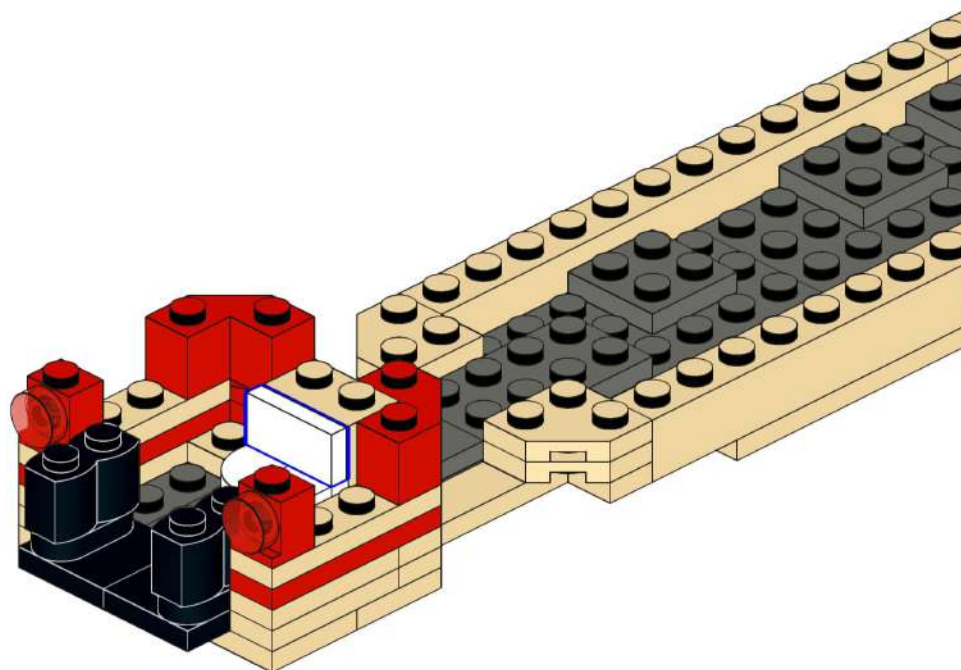

21

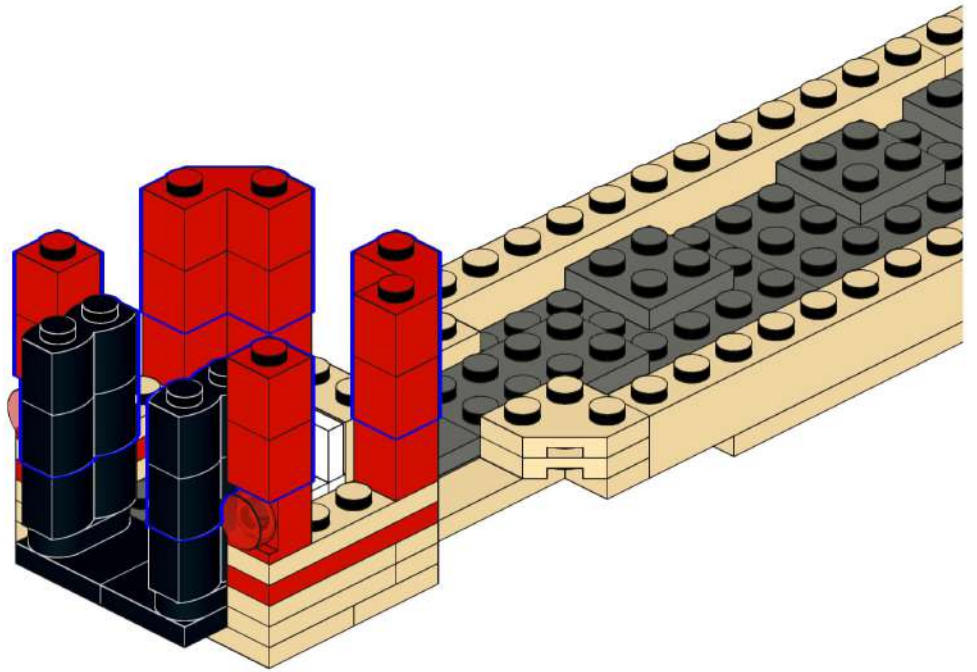

22

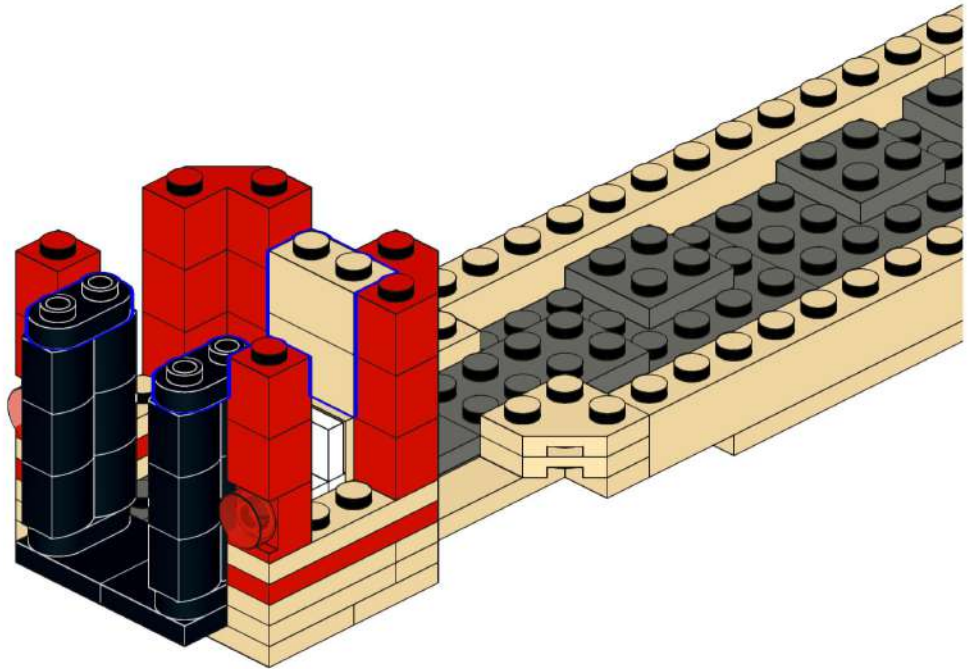
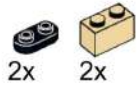

23

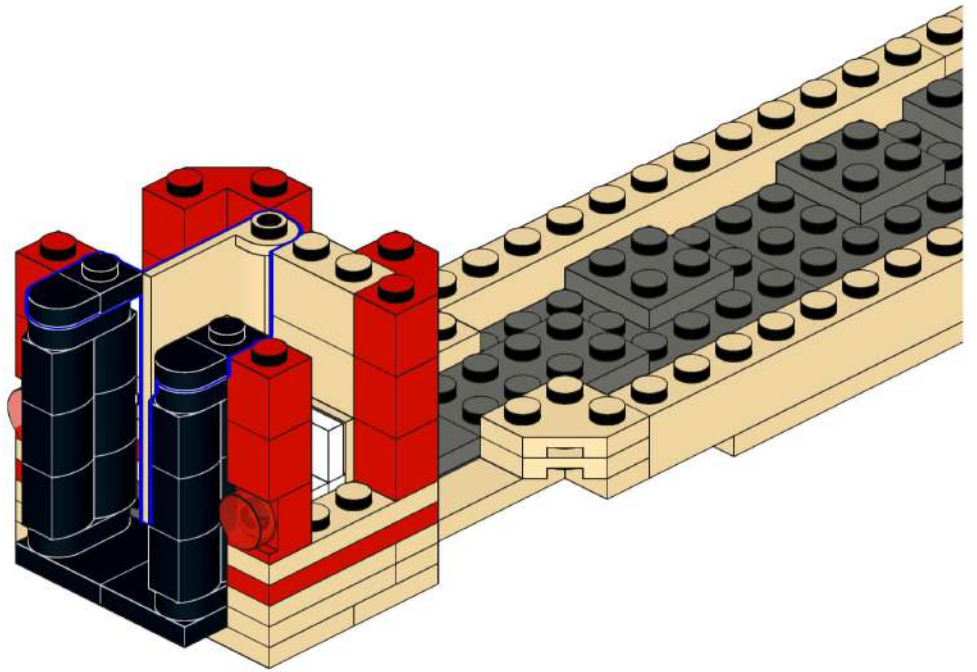
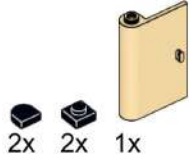

24

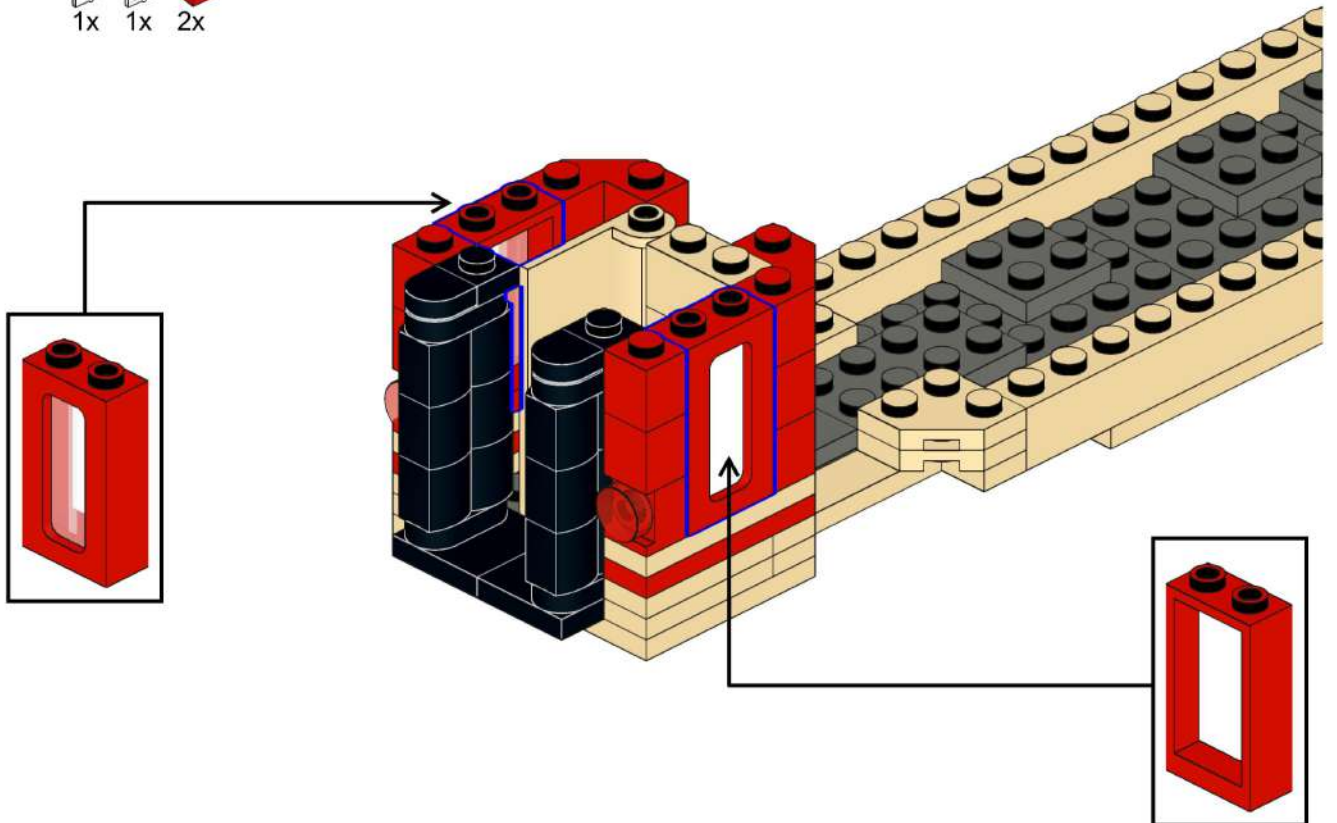
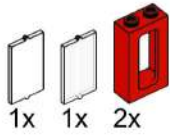

25

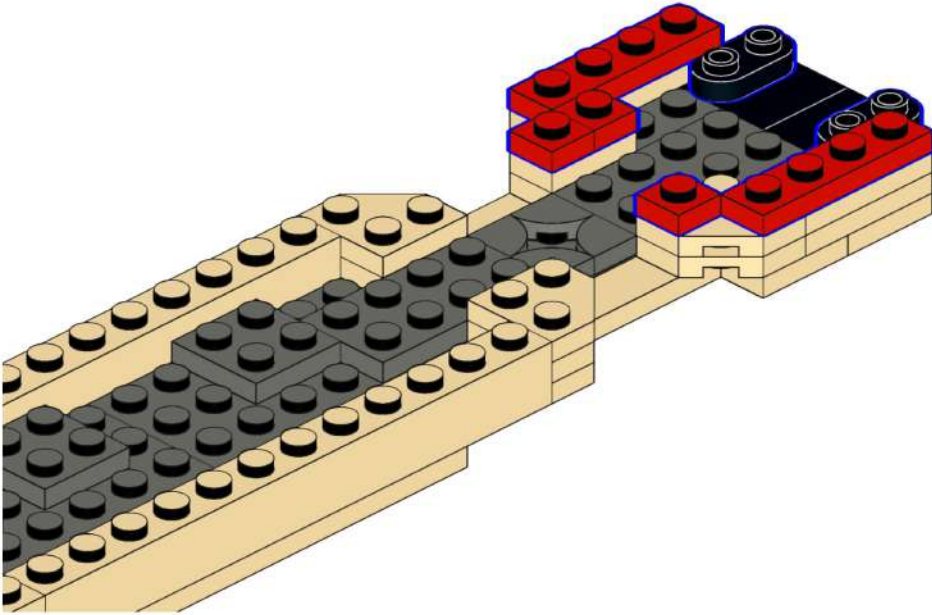

26

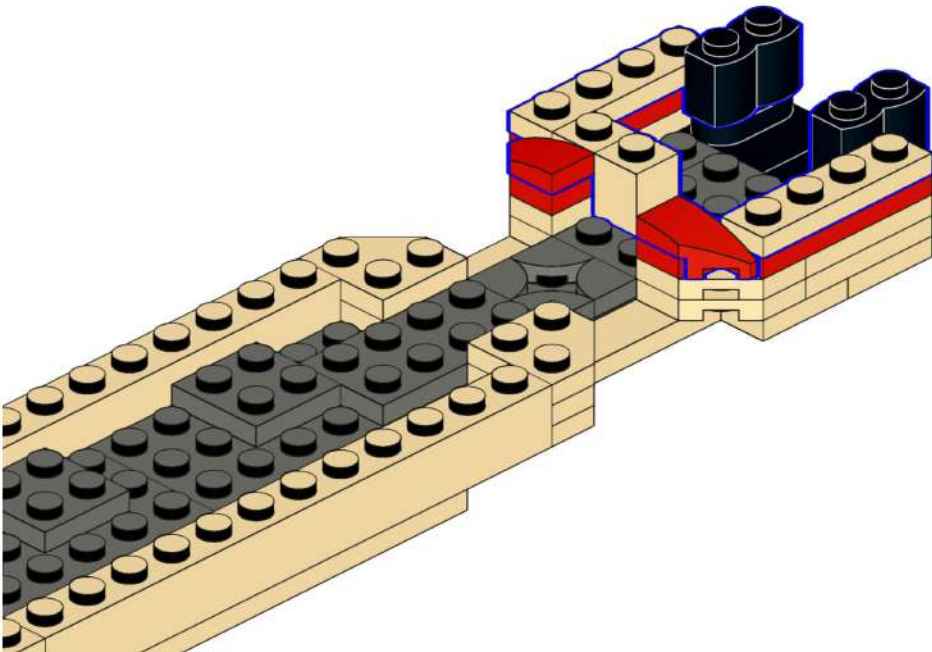
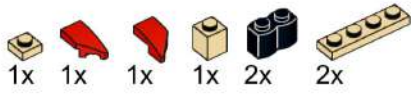

27



- 1x [White 1x1 Technic Brick]
- 2x [Red 1x1 Technic Pin]
- 2x [White 1x2 Technic Brick]
- 2x [Yellow 1x2 Technic Brick]
- 2x [Red 1x2 Technic Brick]
- 1x [White 1x2 Technic Brick]
- 2x [Red 1x2 Technic Brick]
- 1x [Yellow 1x2 Technic Brick]

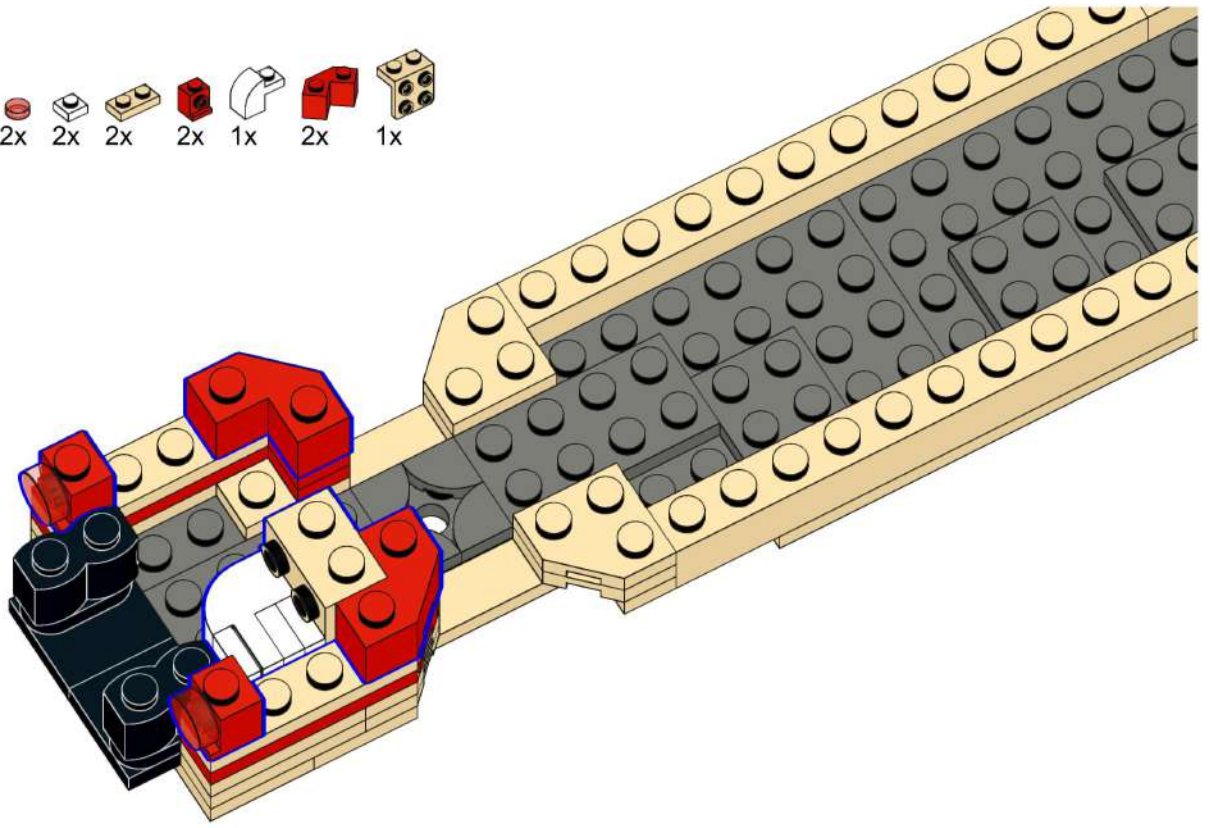

28

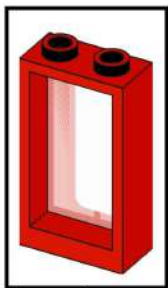

- 1x [White 1x1 Technic Brick]
- 4x [Red 1x1 Technic Pin]
- 2x [Yellow 1x2 Technic Brick]
- 4x [Red 1x2 Technic Brick]
- 1x [White 1x2 Technic Brick]
- 1x [White 1x2 Technic Brick]
- 2x [Red 1x2 Technic Brick]

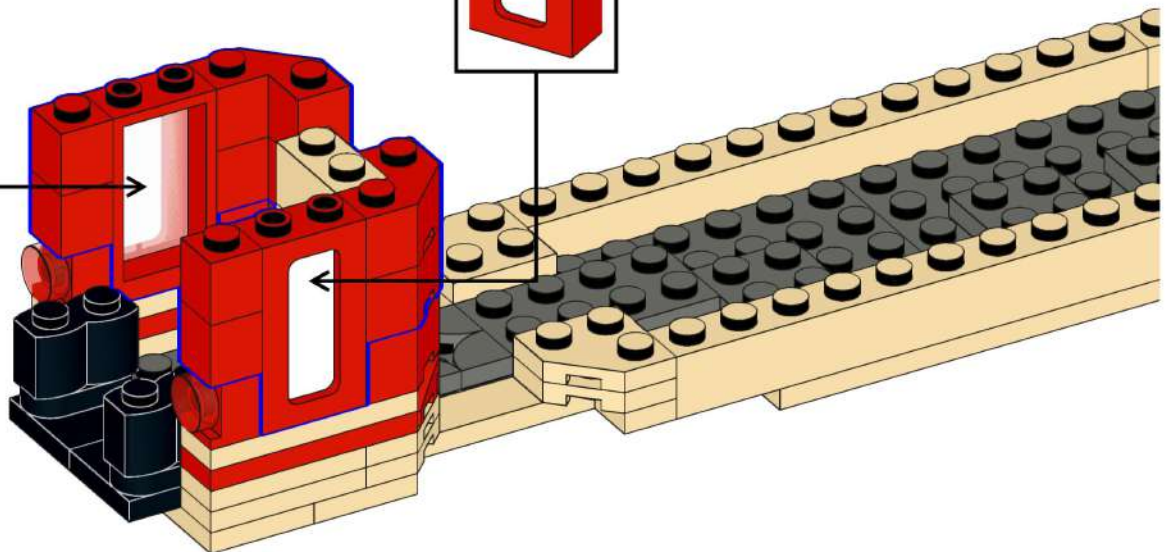
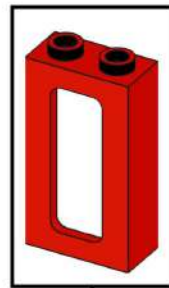

31

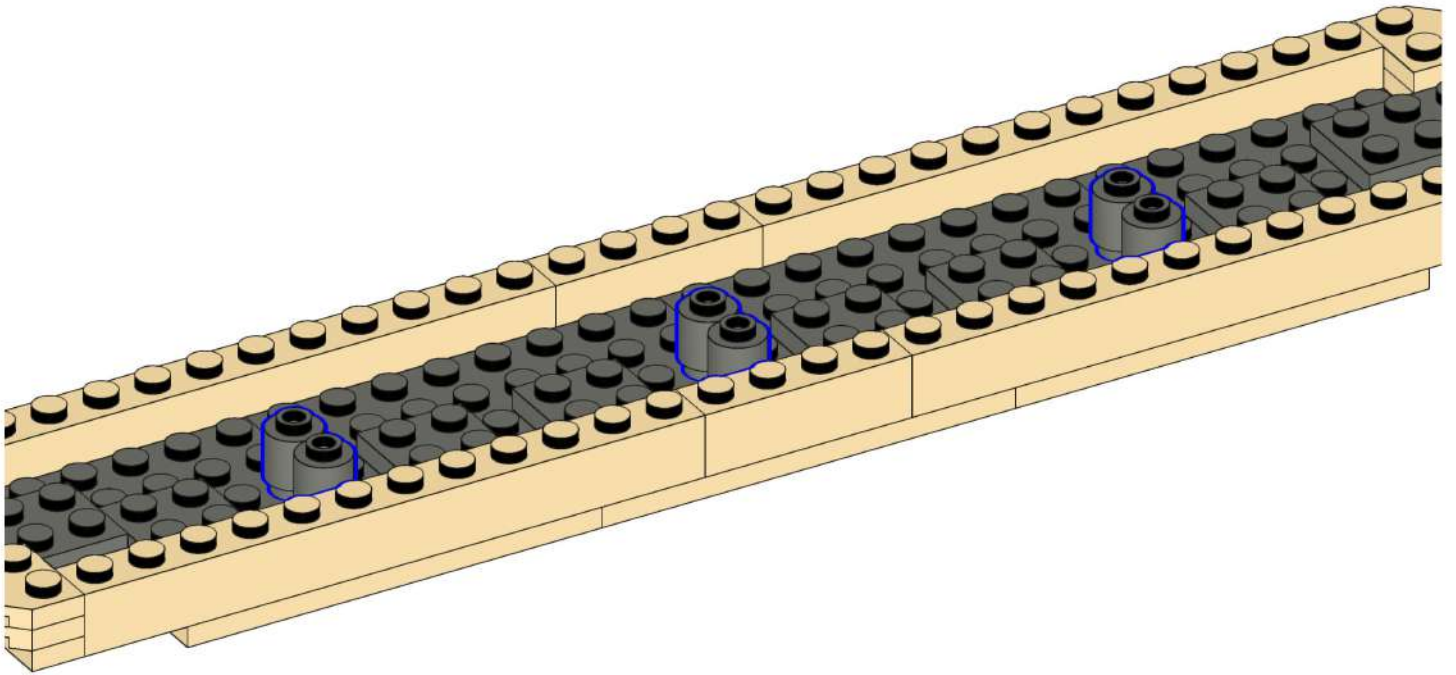

32

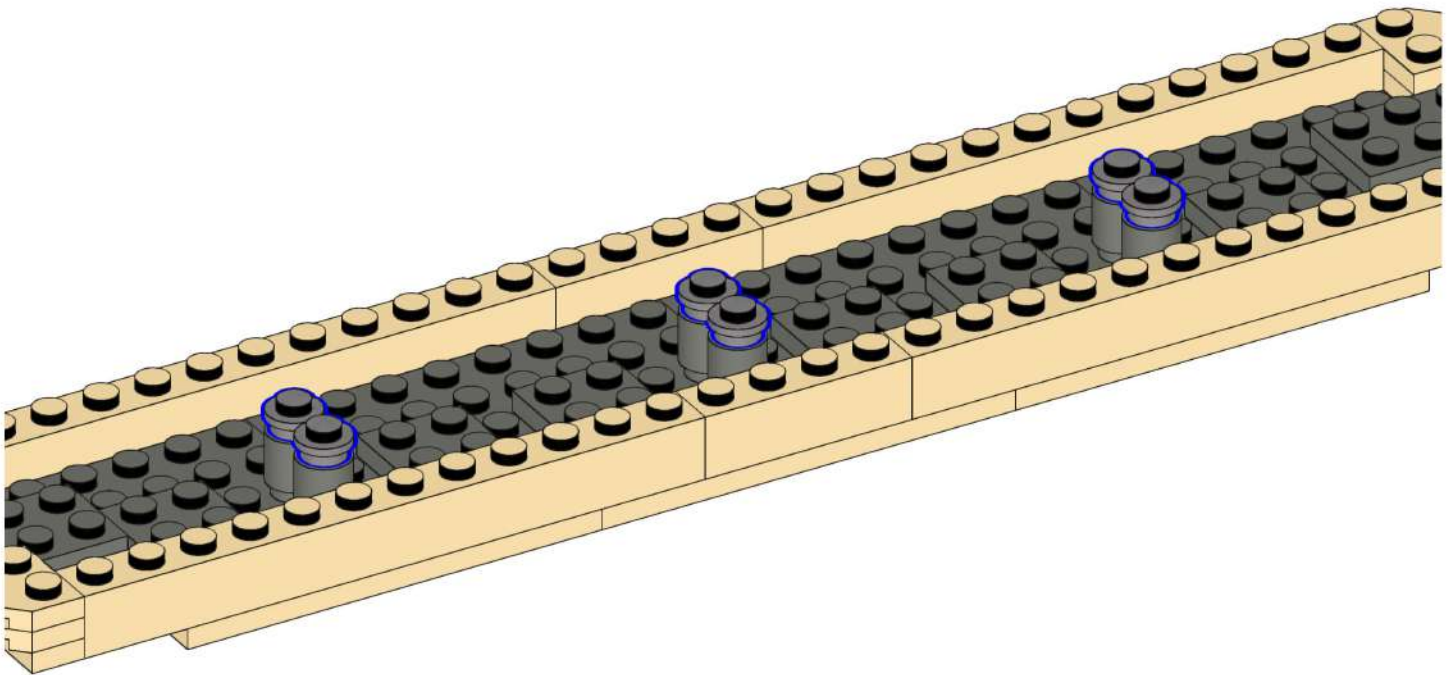

33

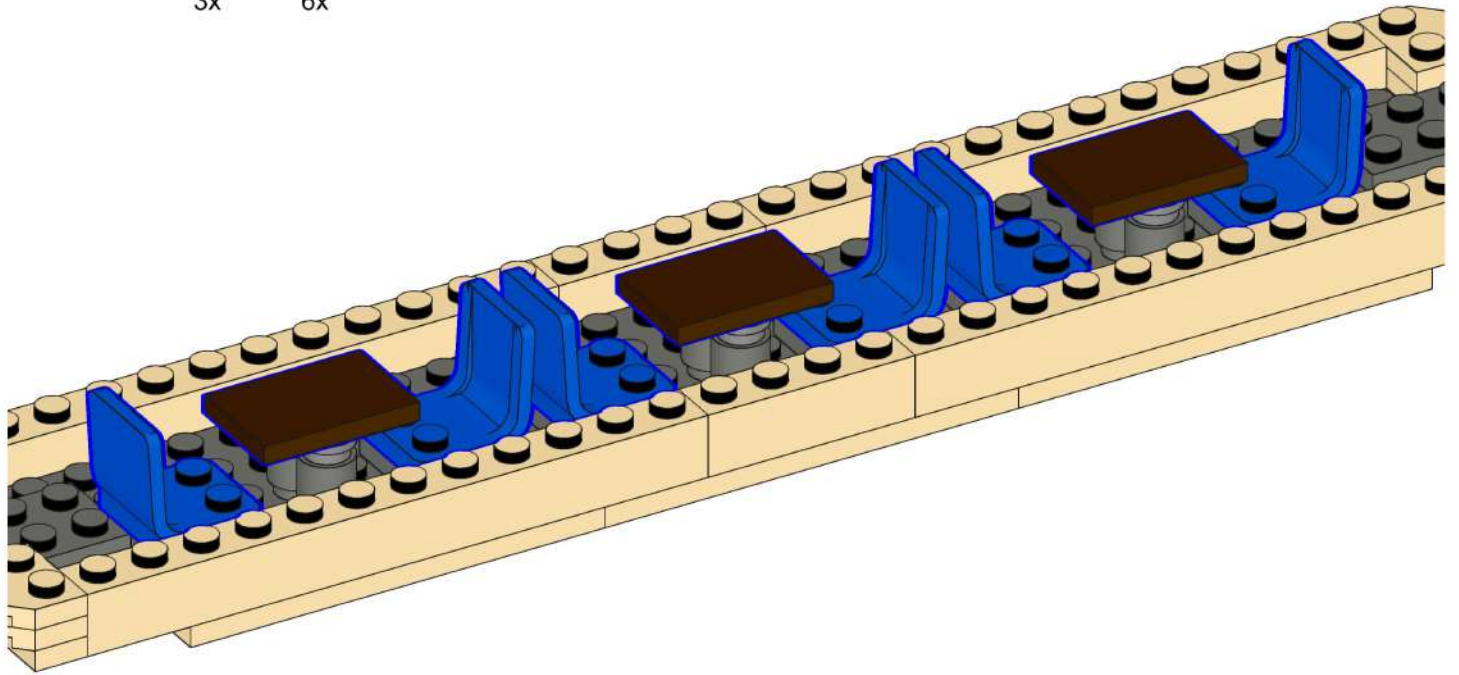
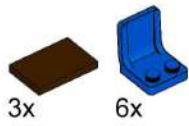

34

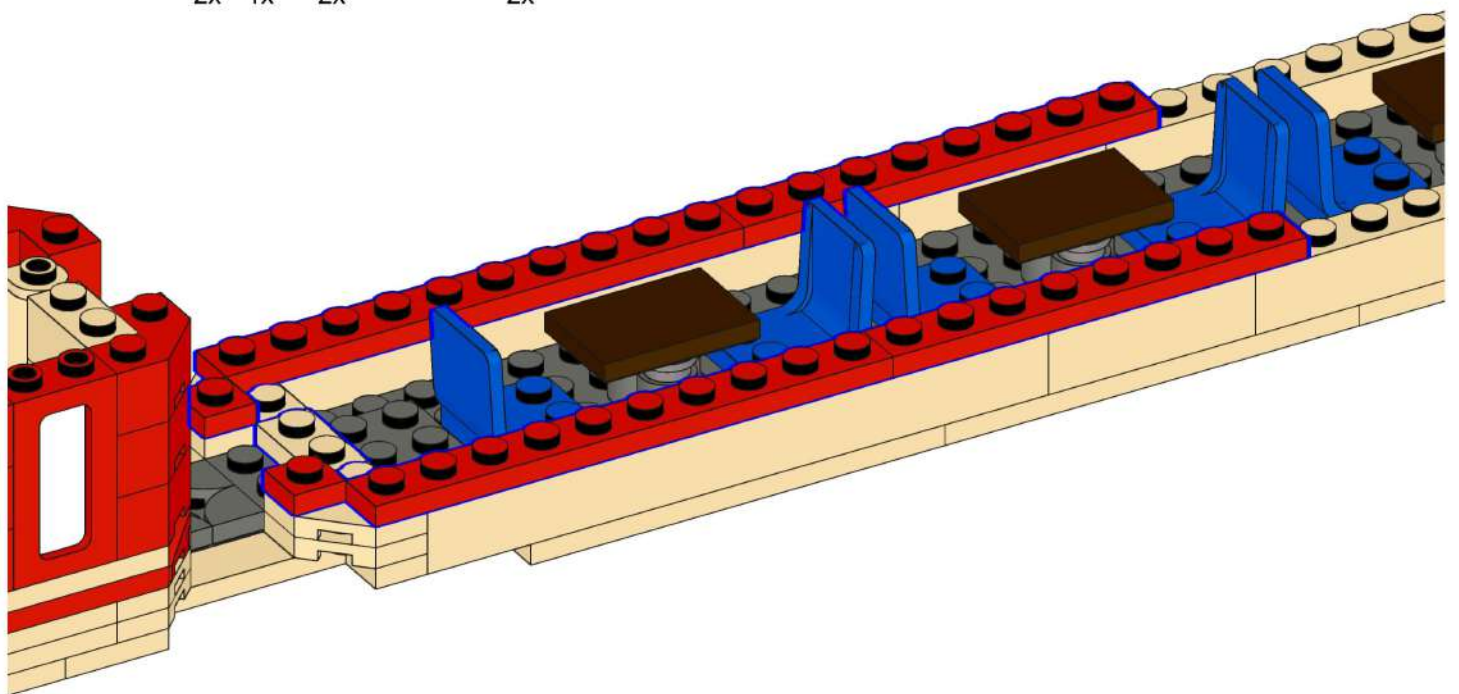
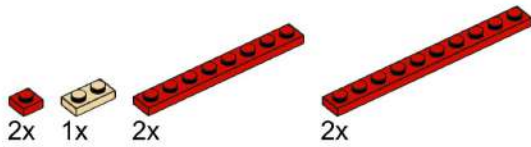

35

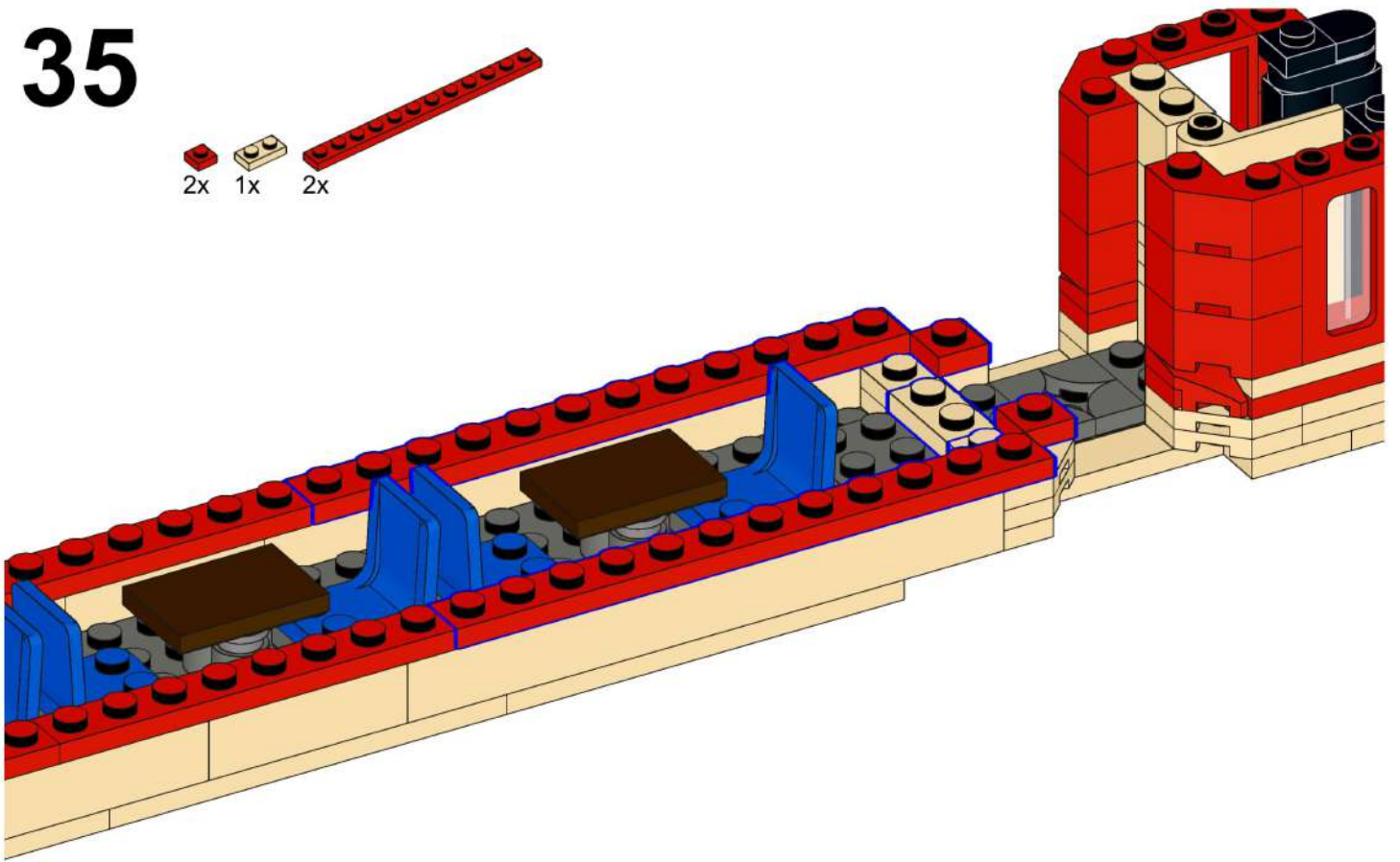
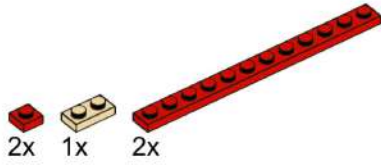

36

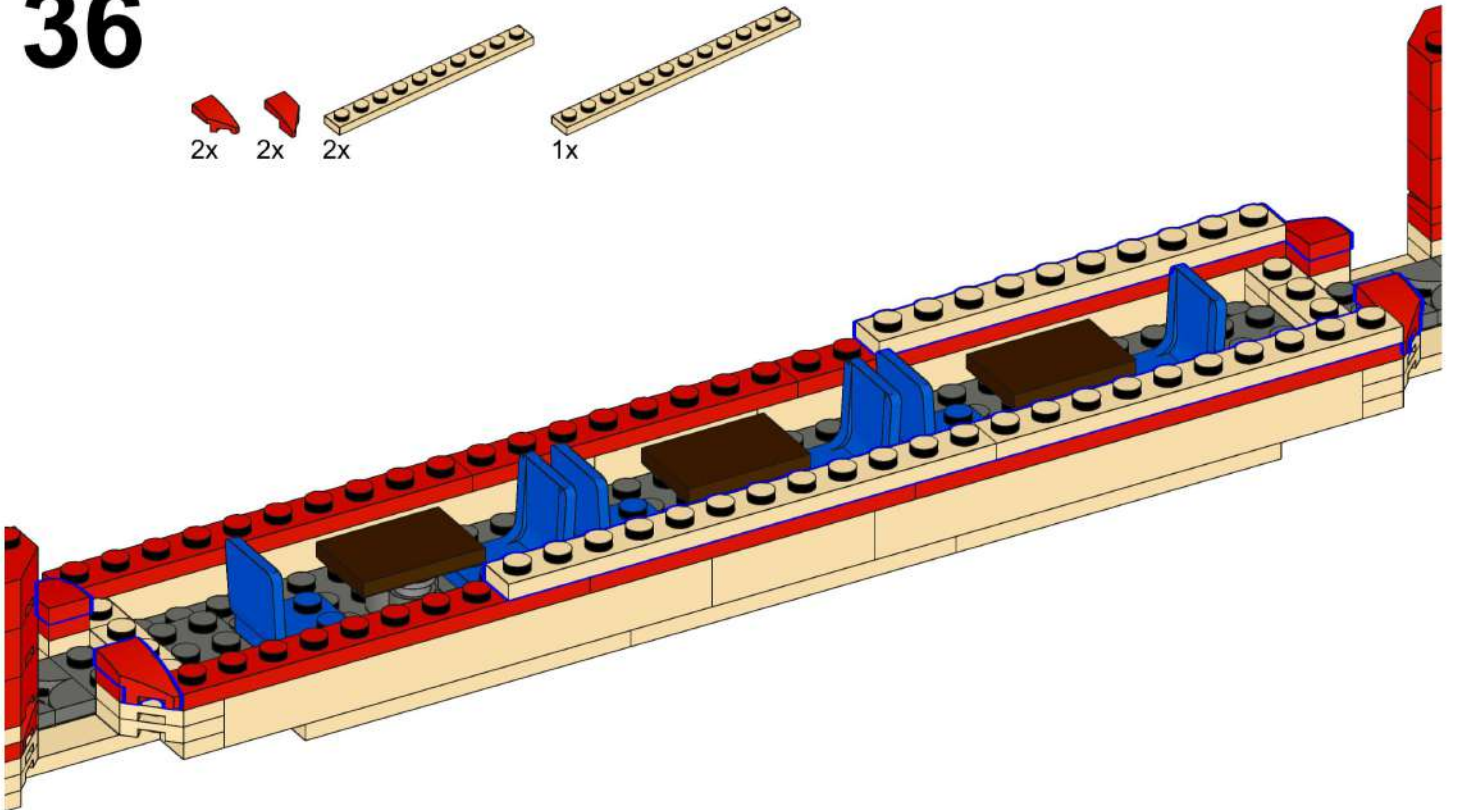
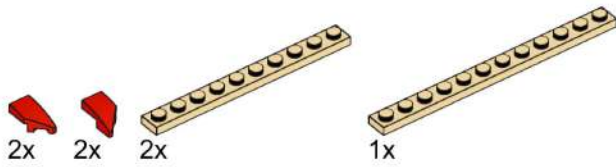

37

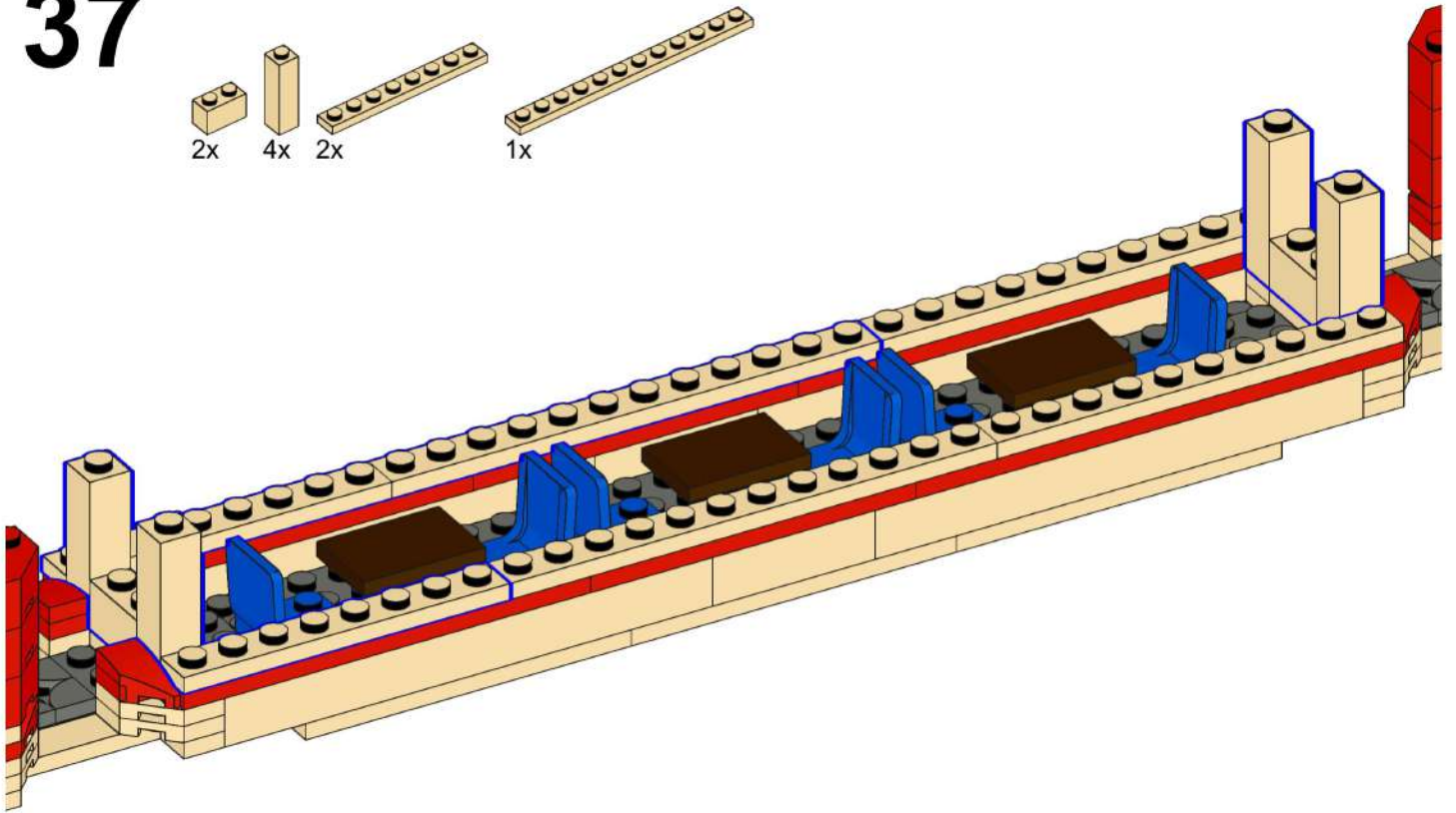
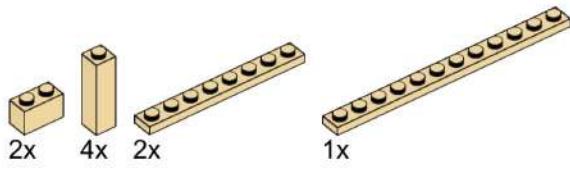

38

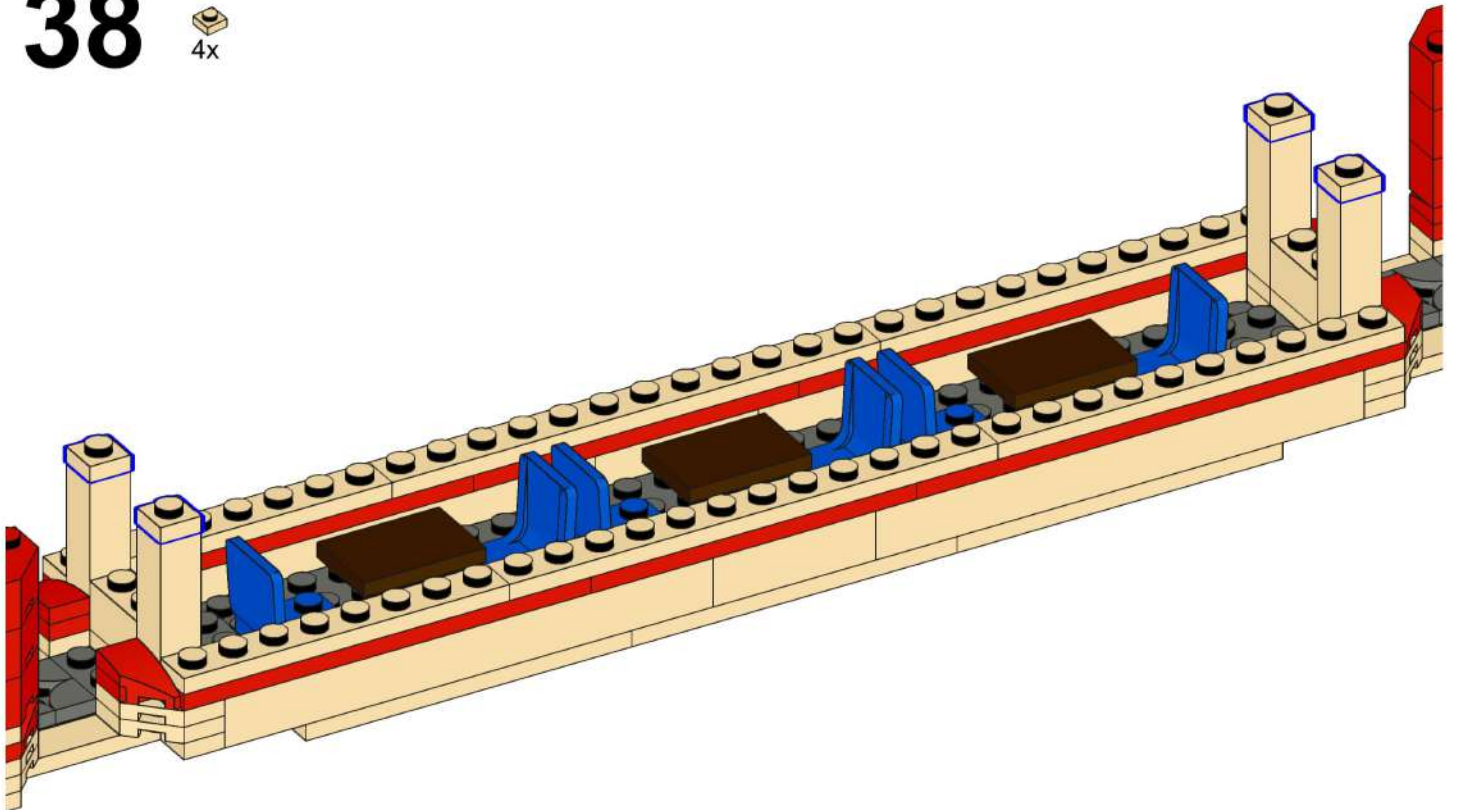

39

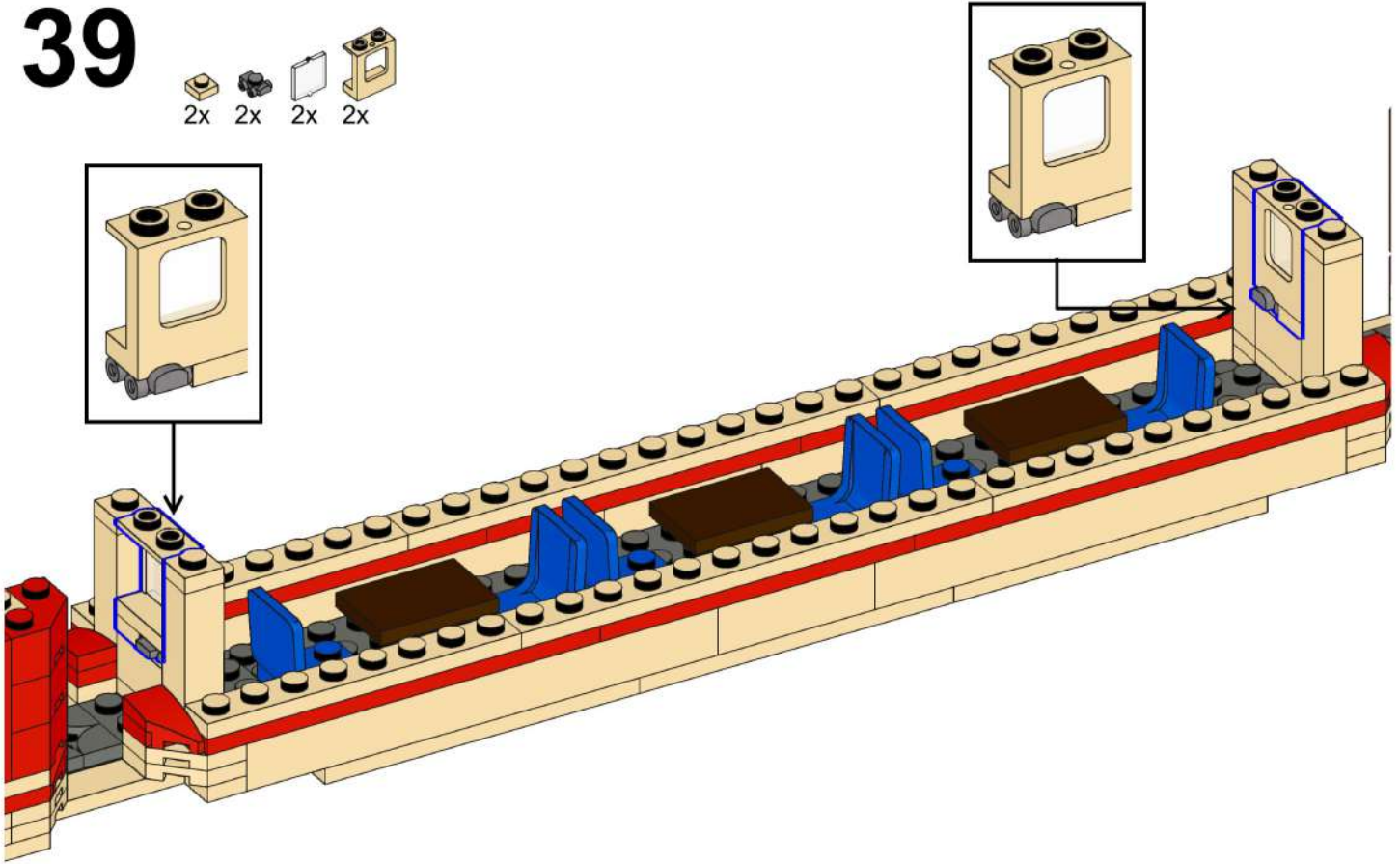
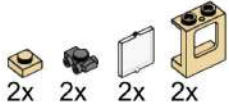

40

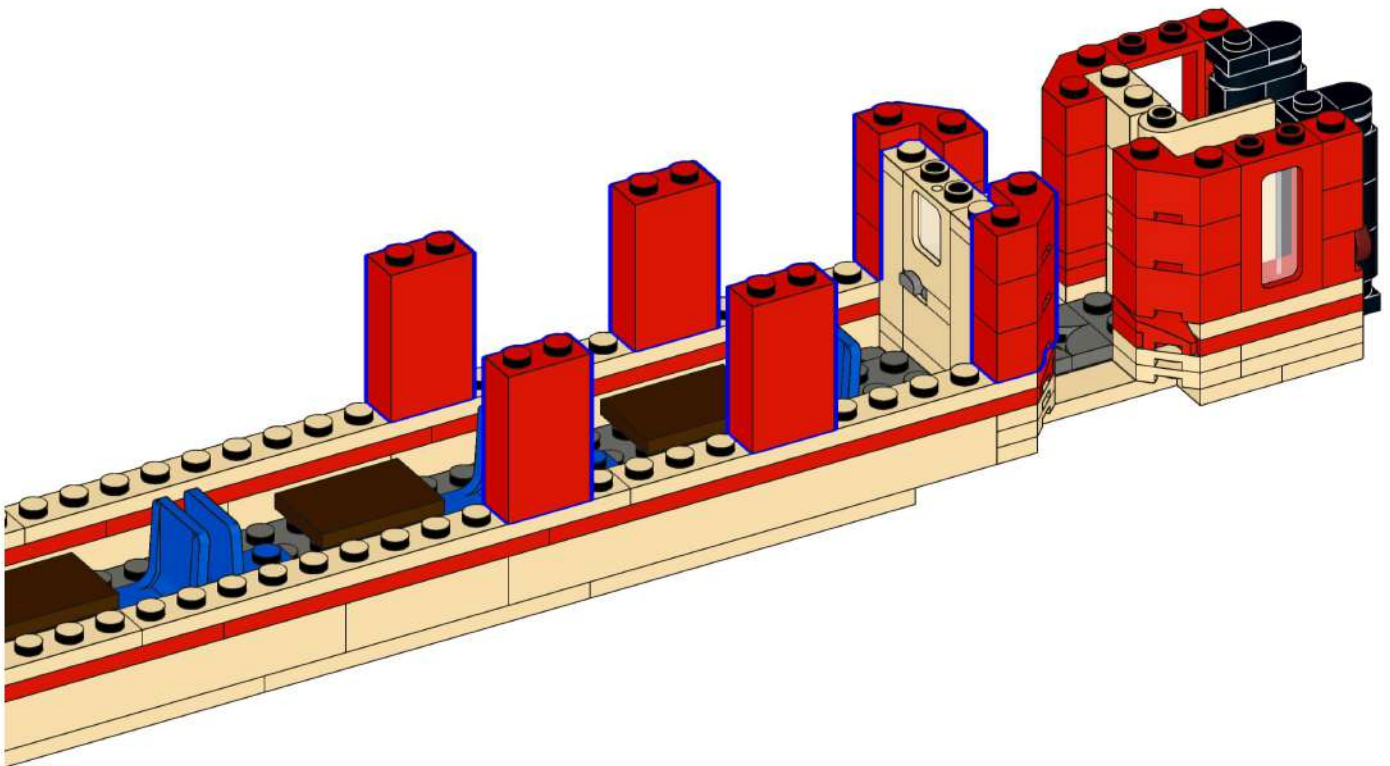
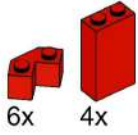

41

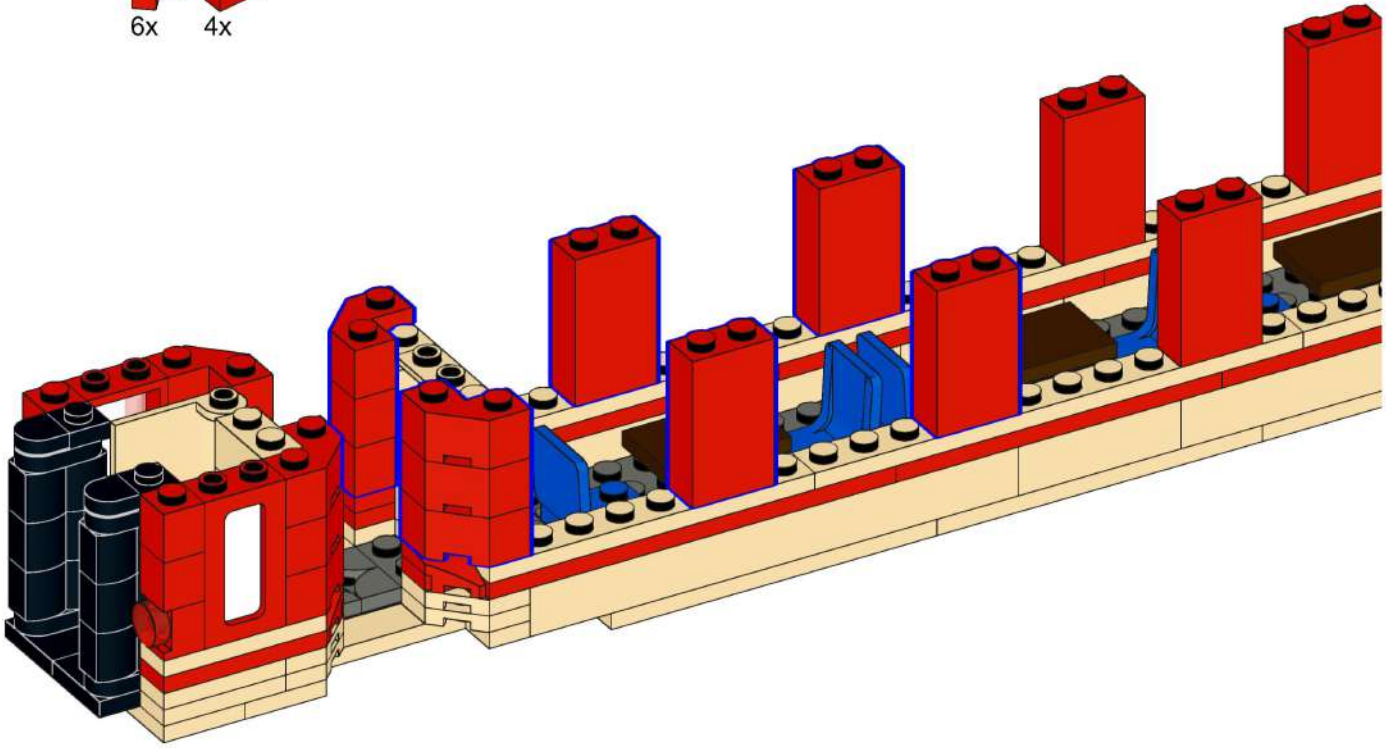
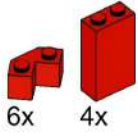

42

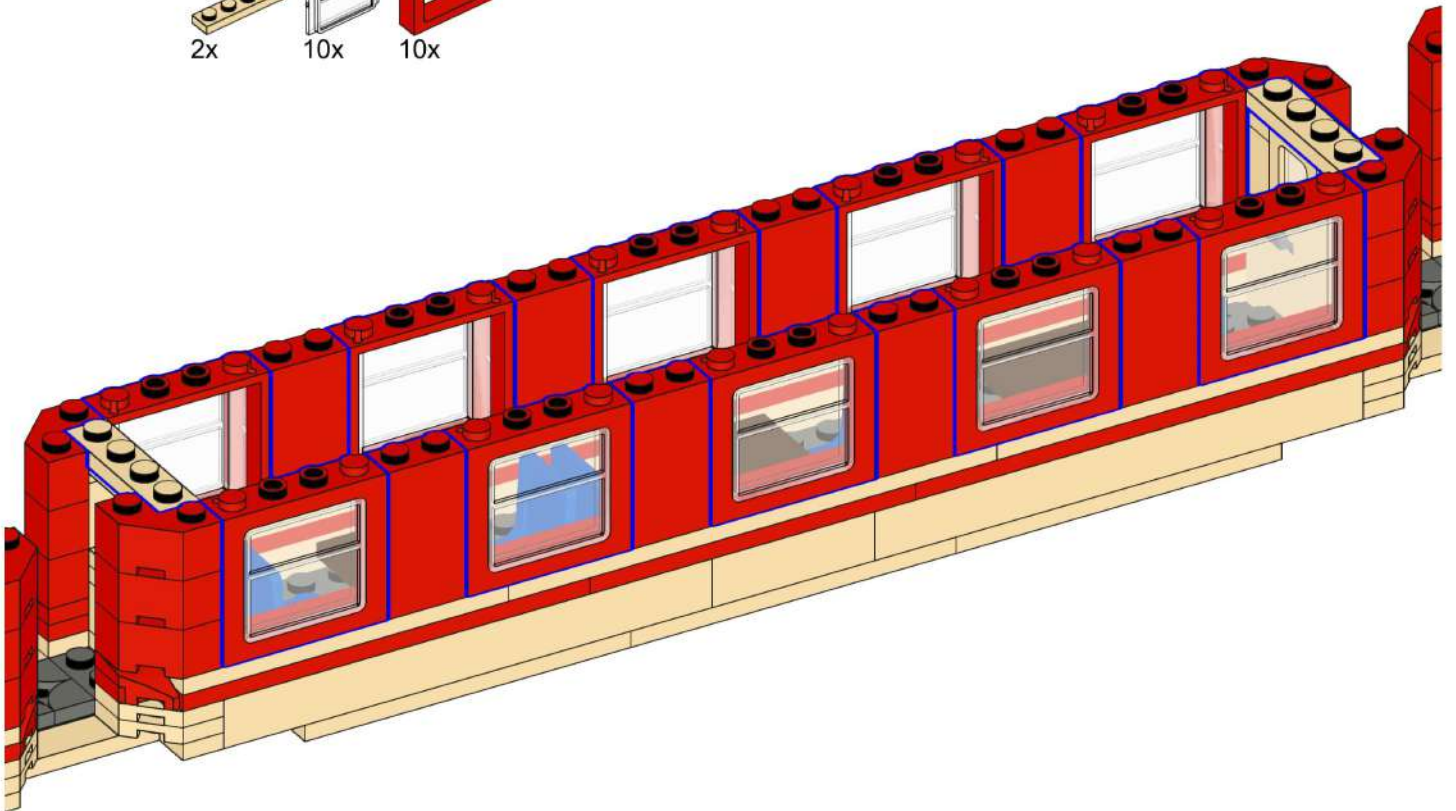
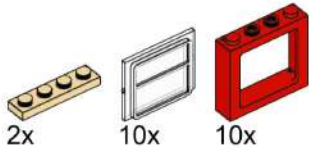

43

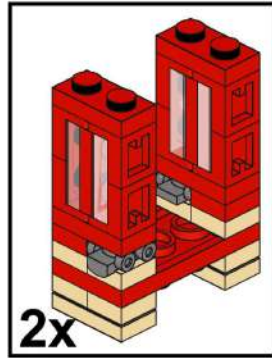
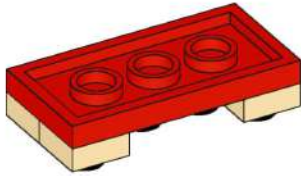
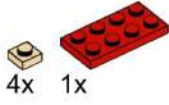

44

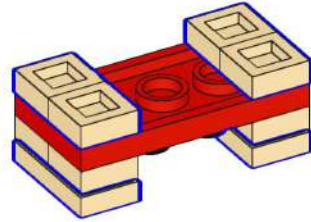

45

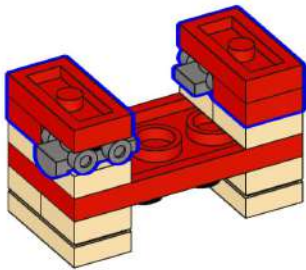
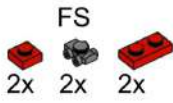

46

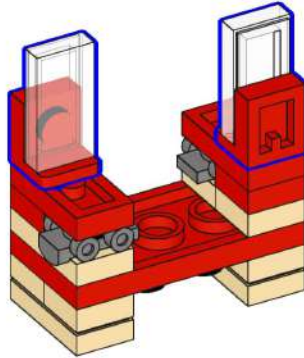

47

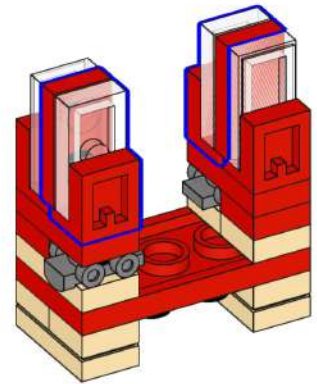
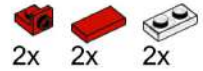

48

4x 

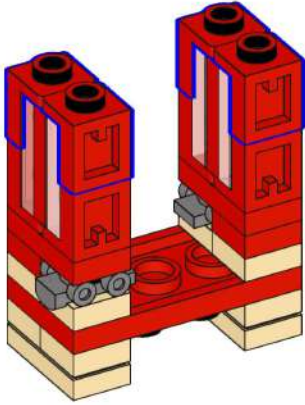

49

2x 

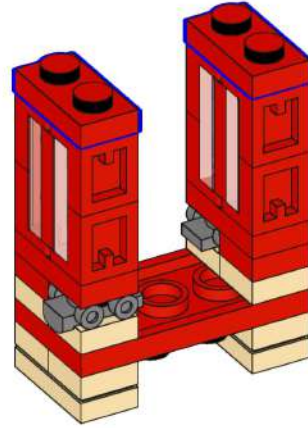

50

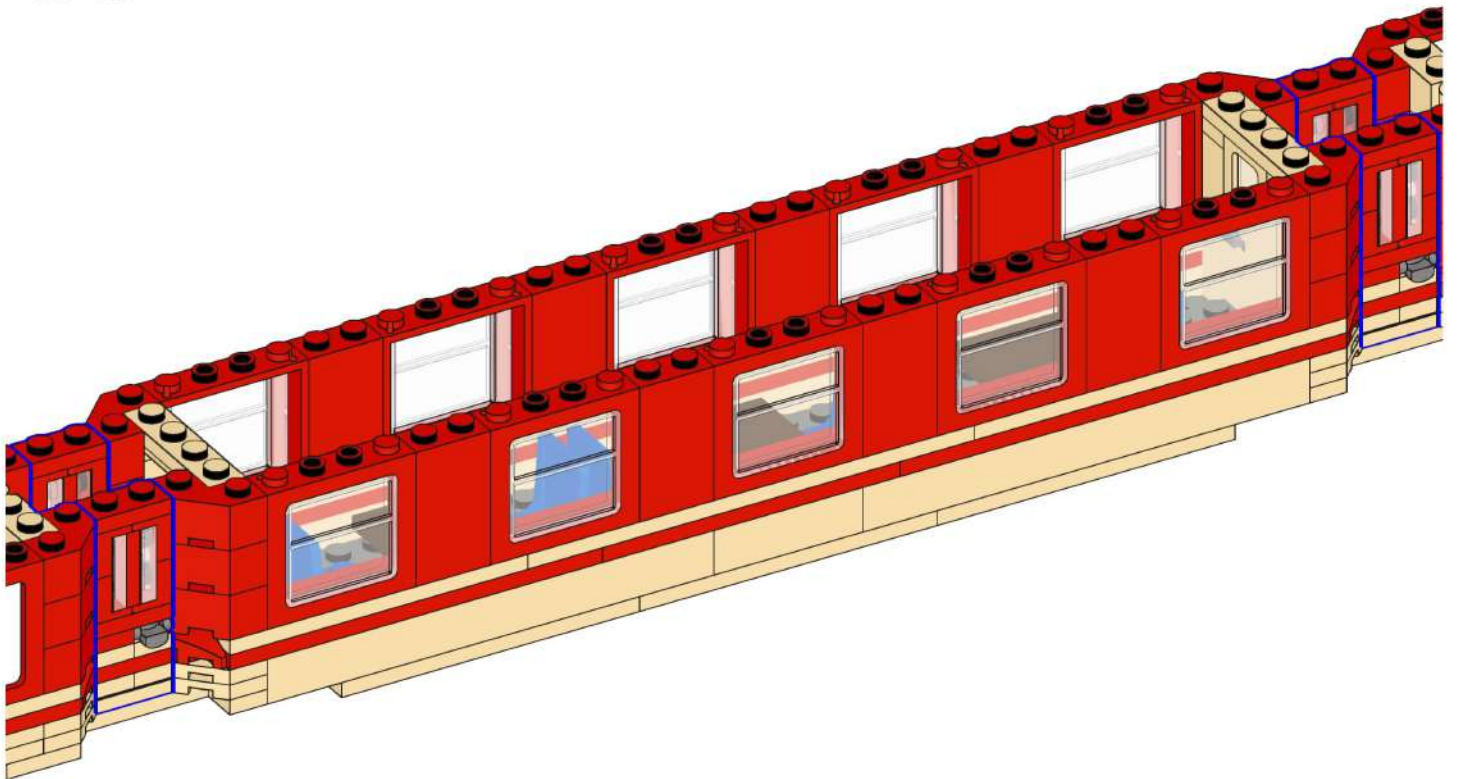

51



- FS
- 2x
- 2x
- 8x
- 4x
- 2x
- 4x
- 2x
- 4x
- 2x
- 4x

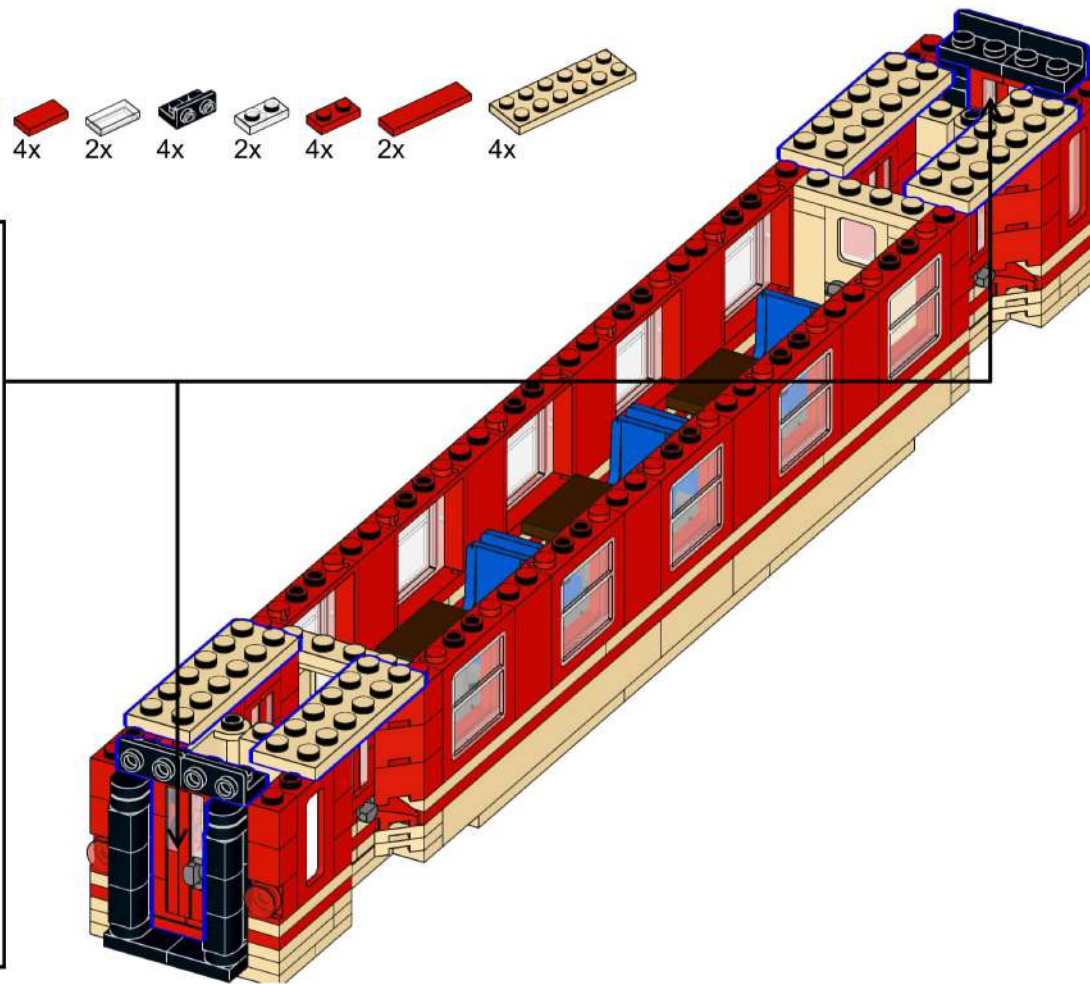
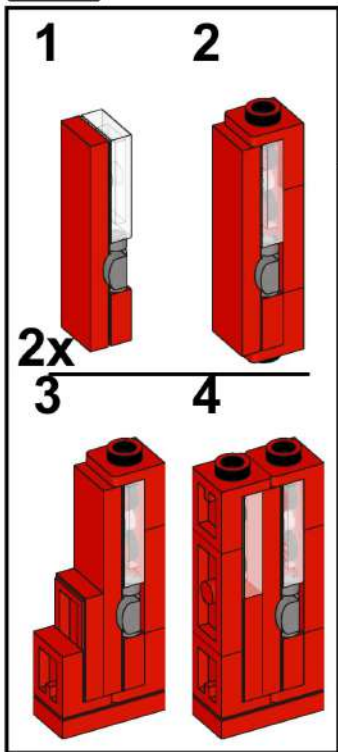

52

- 4x
- 3x

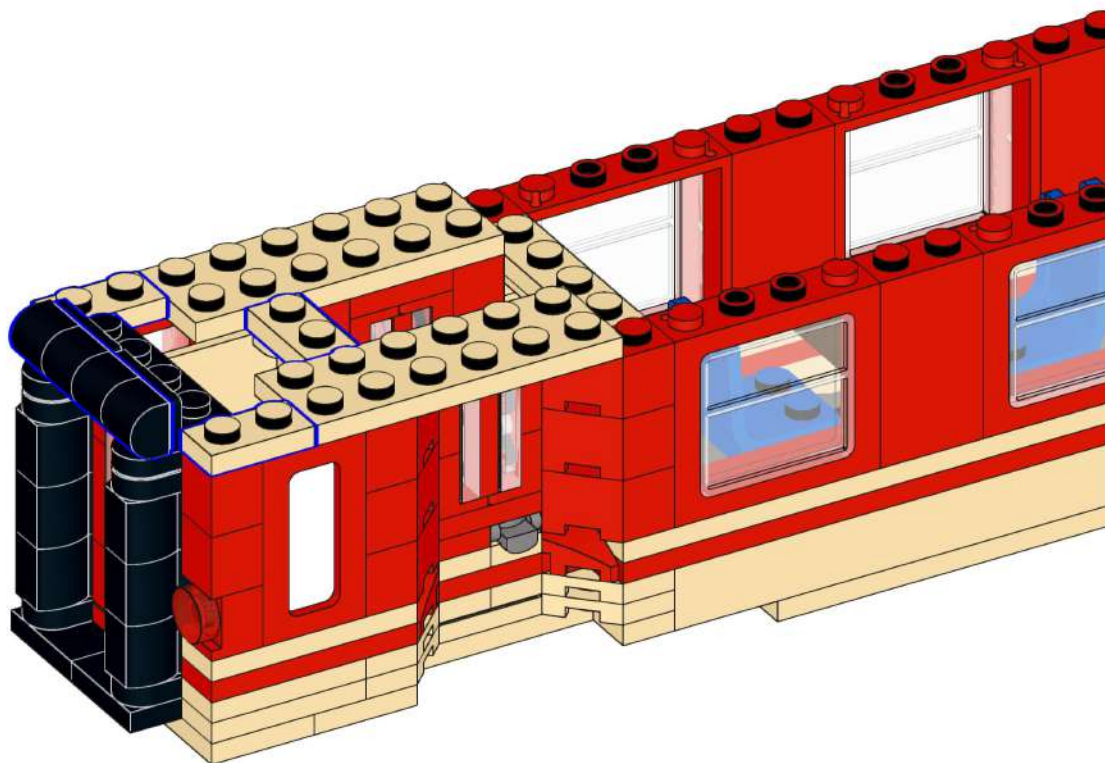

53

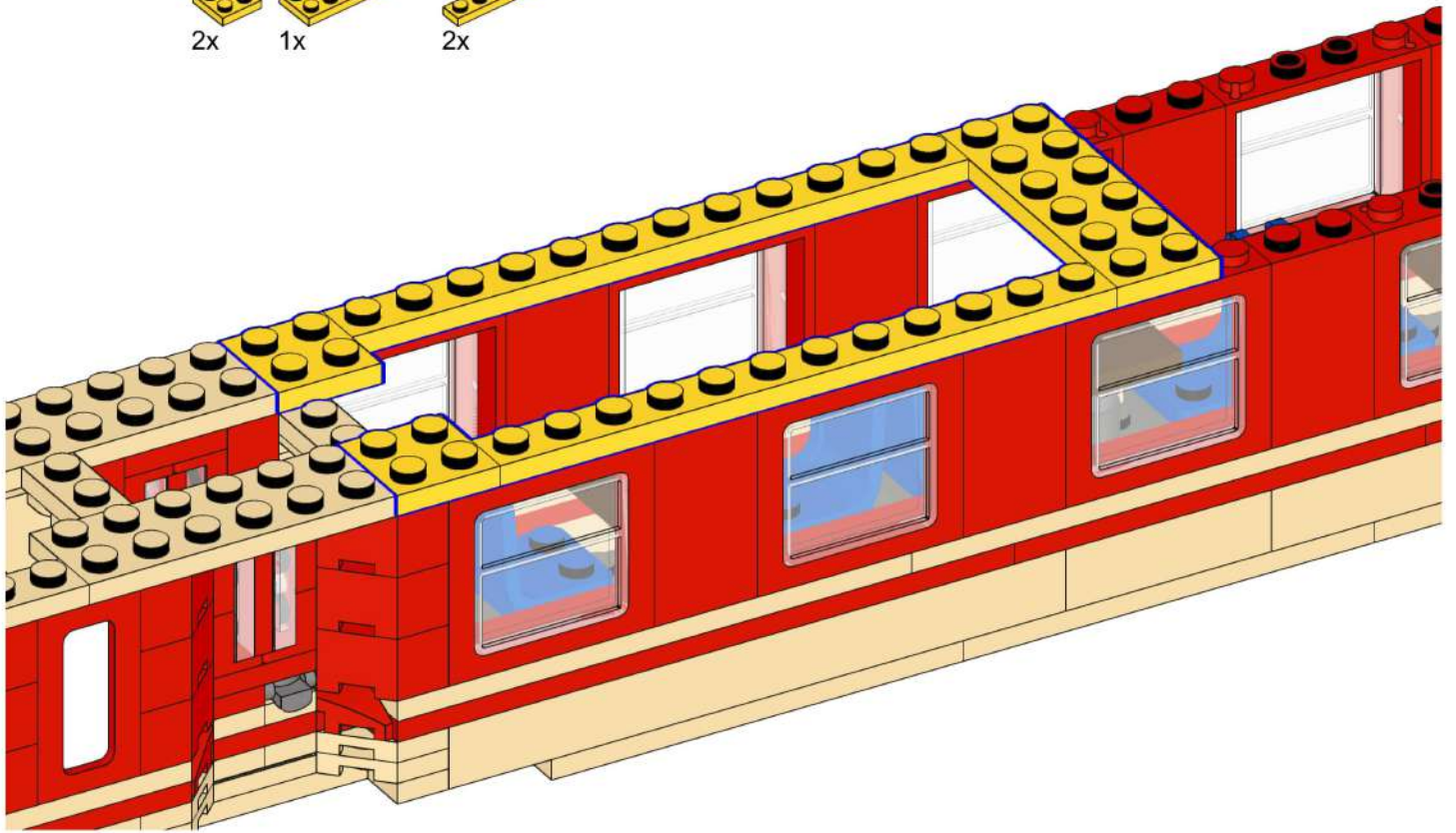
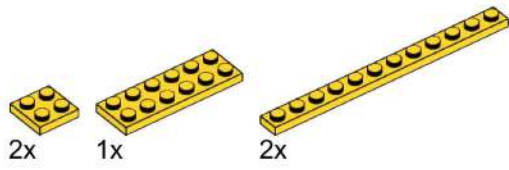

54

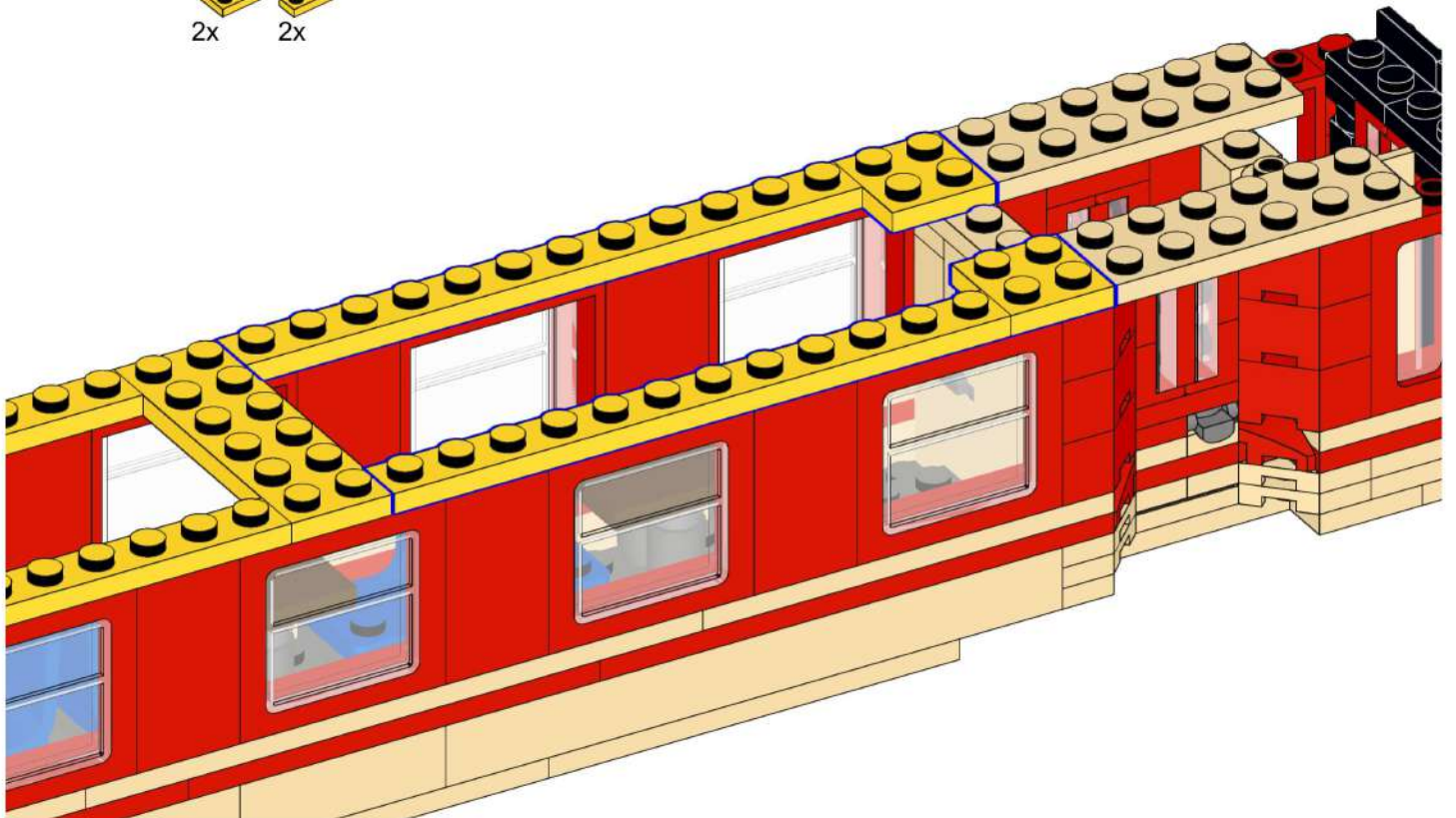
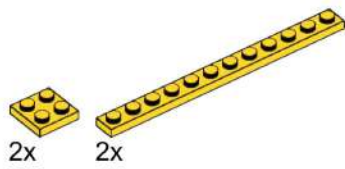

55

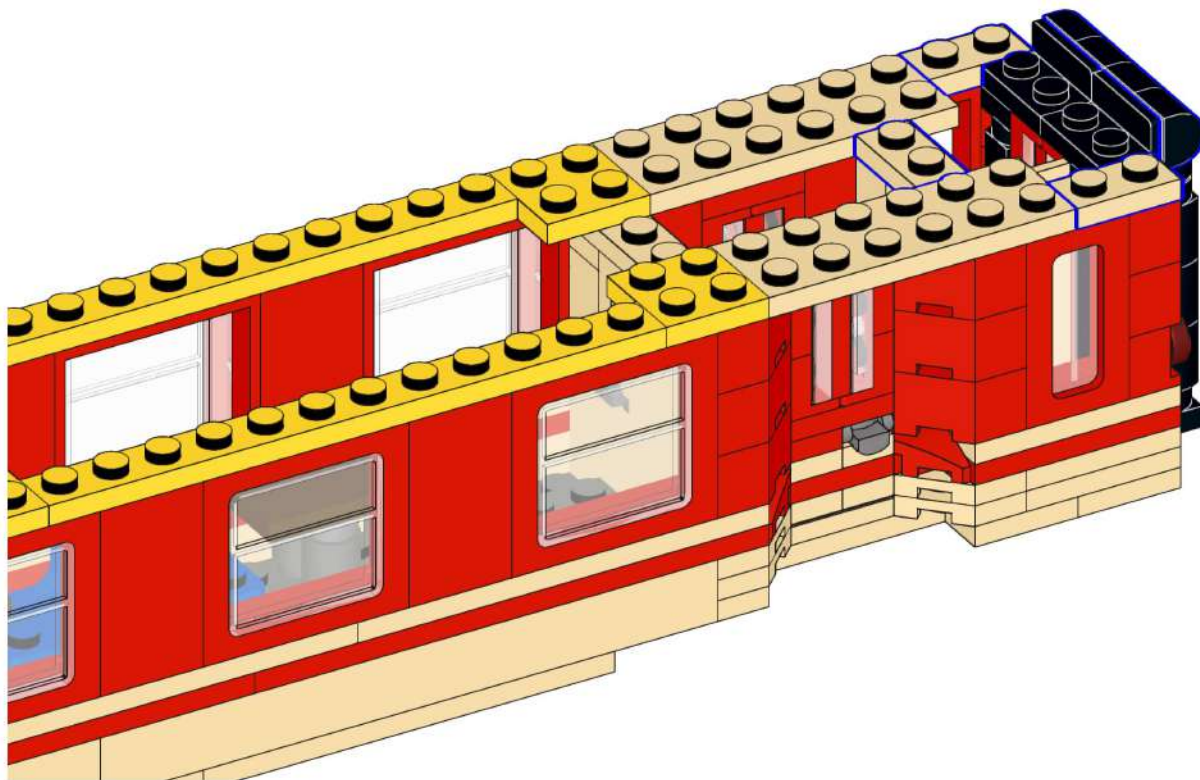

56

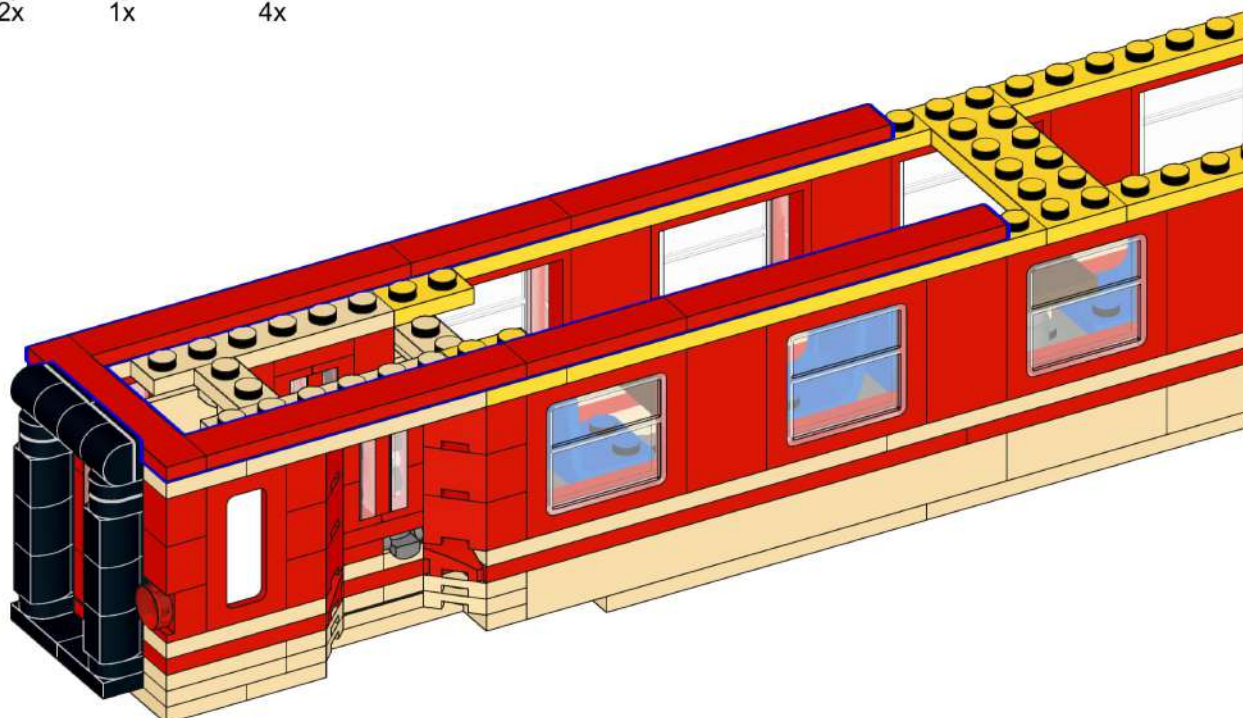
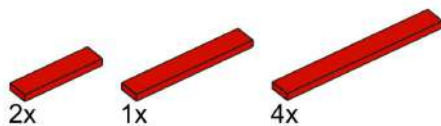

57

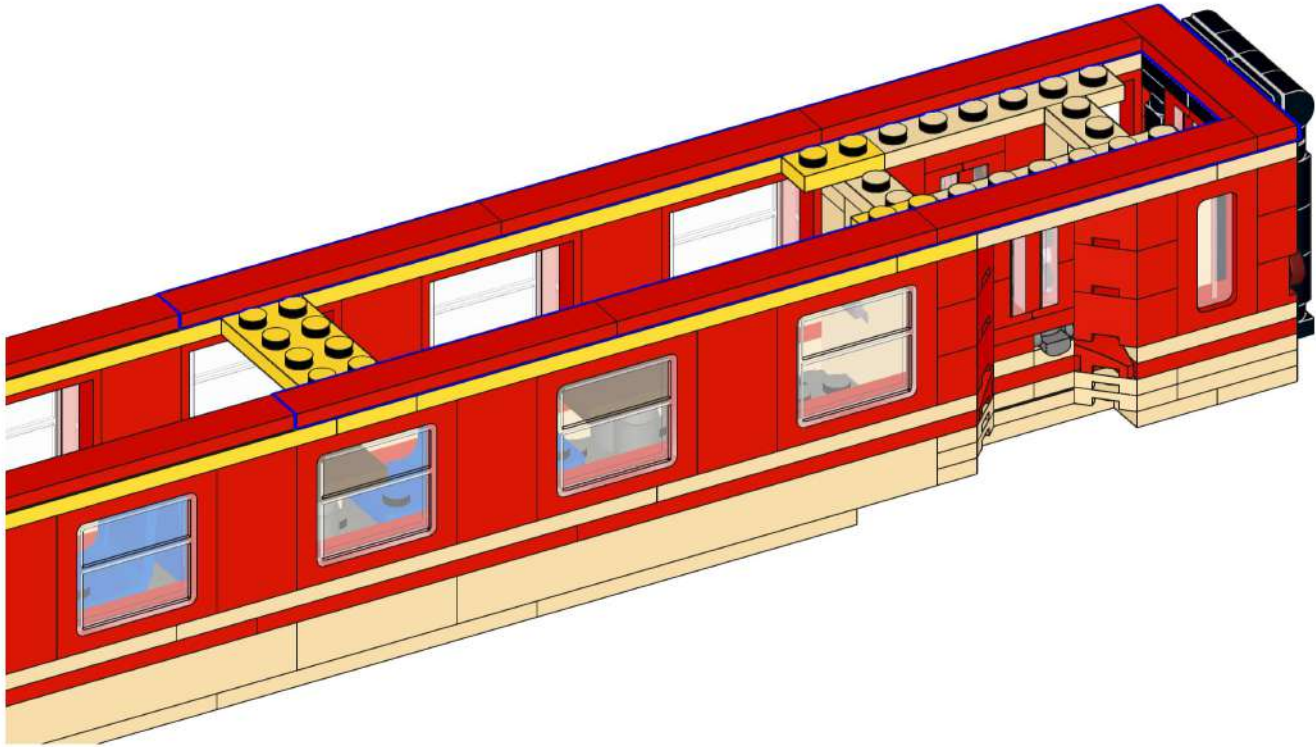
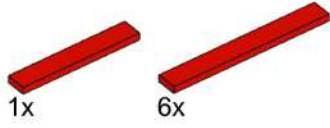

58

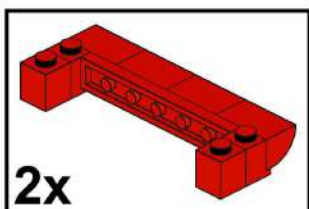
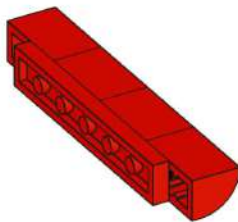
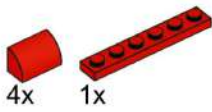

59

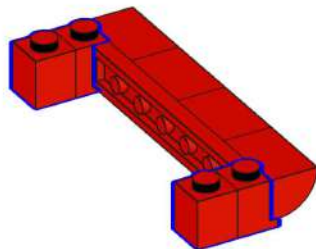
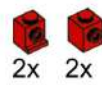

60

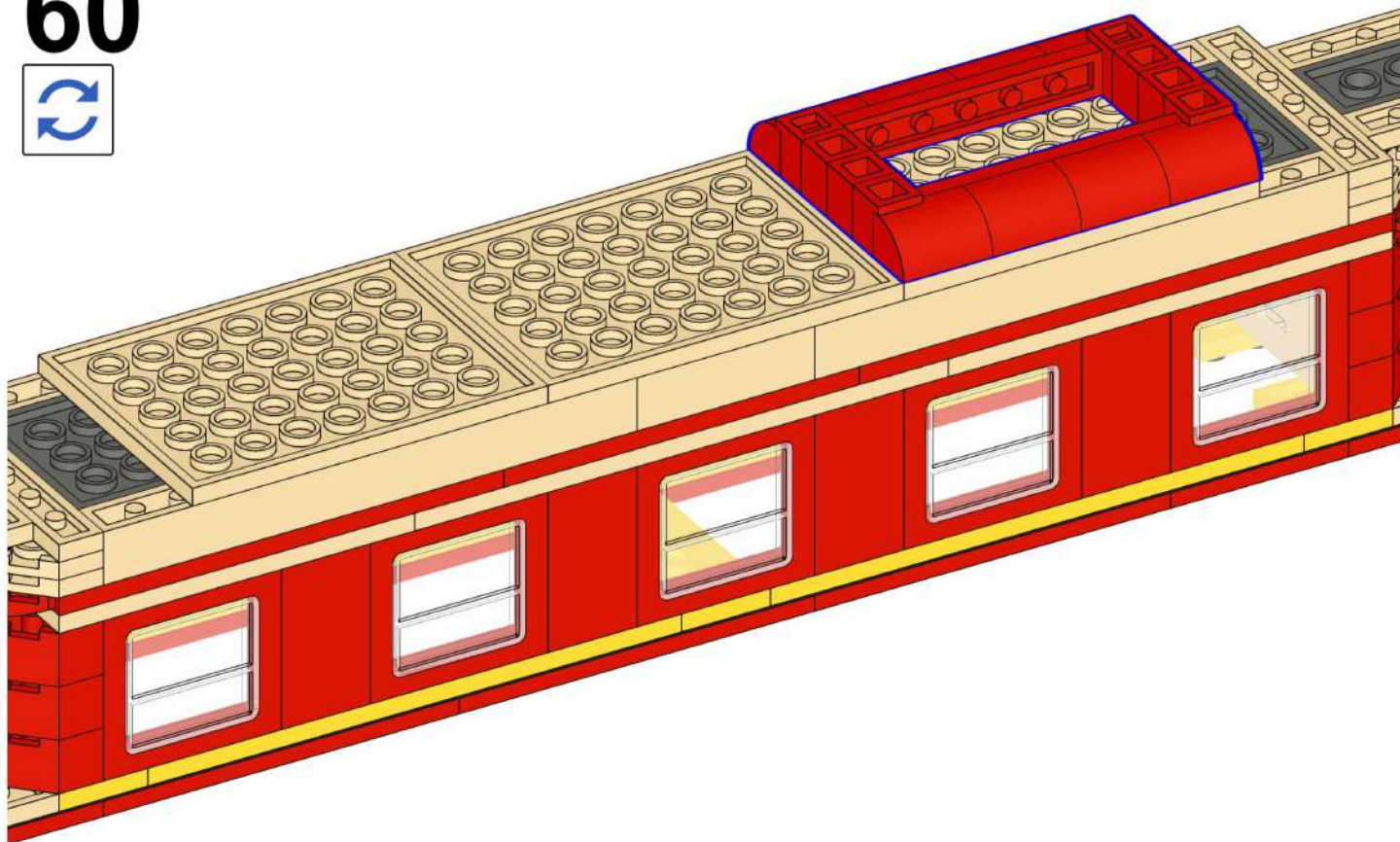

61

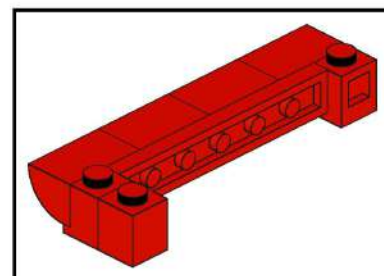
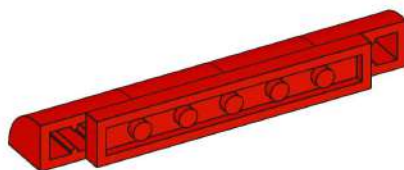
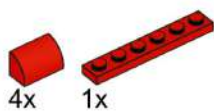

62

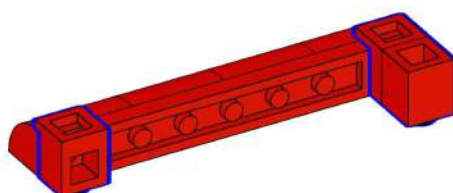
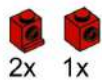

63

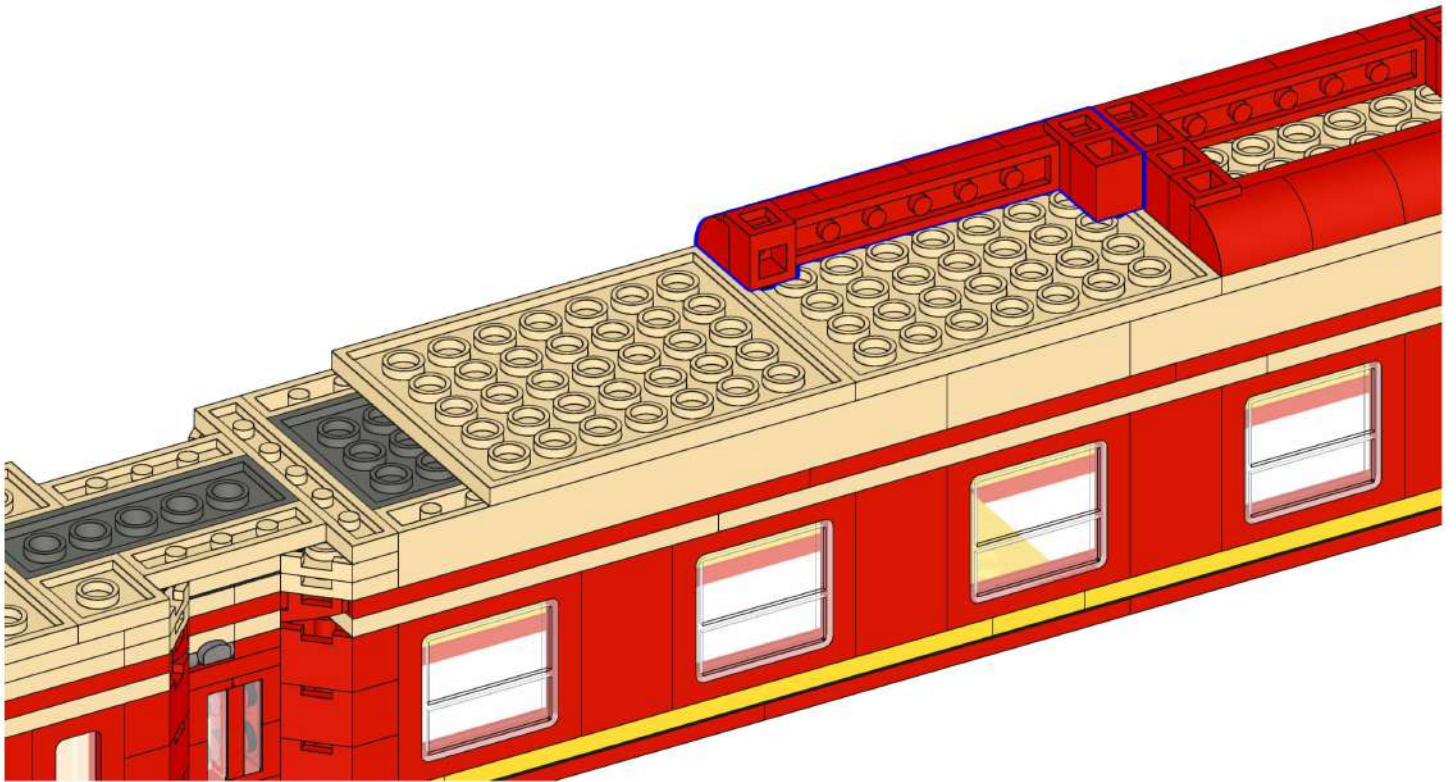

64

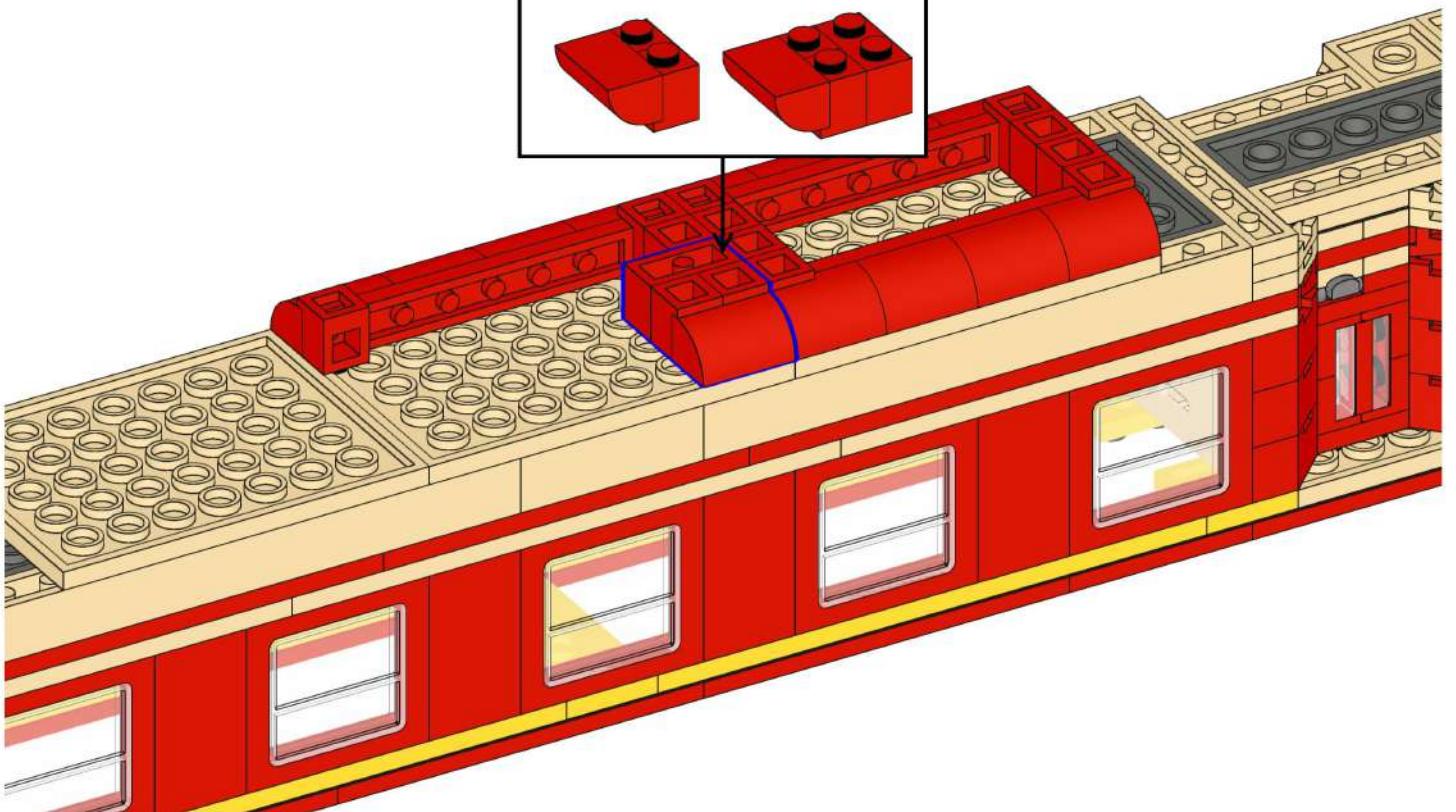
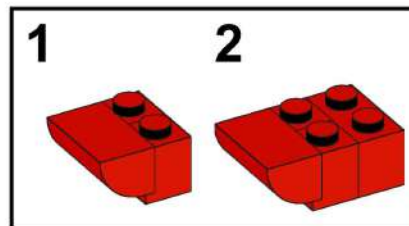
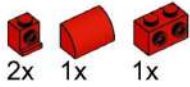

65

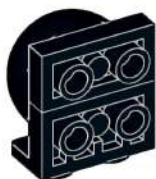

66

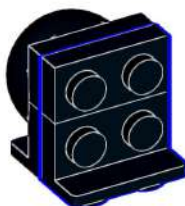

67

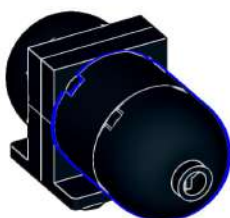

68

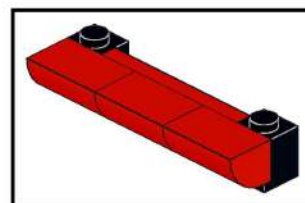
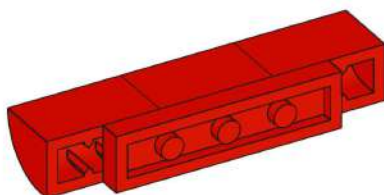
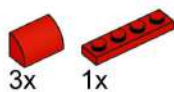

69

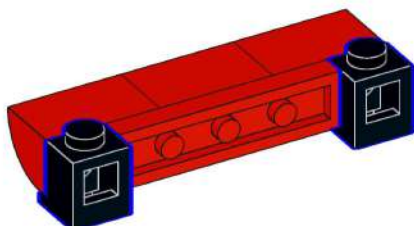

70

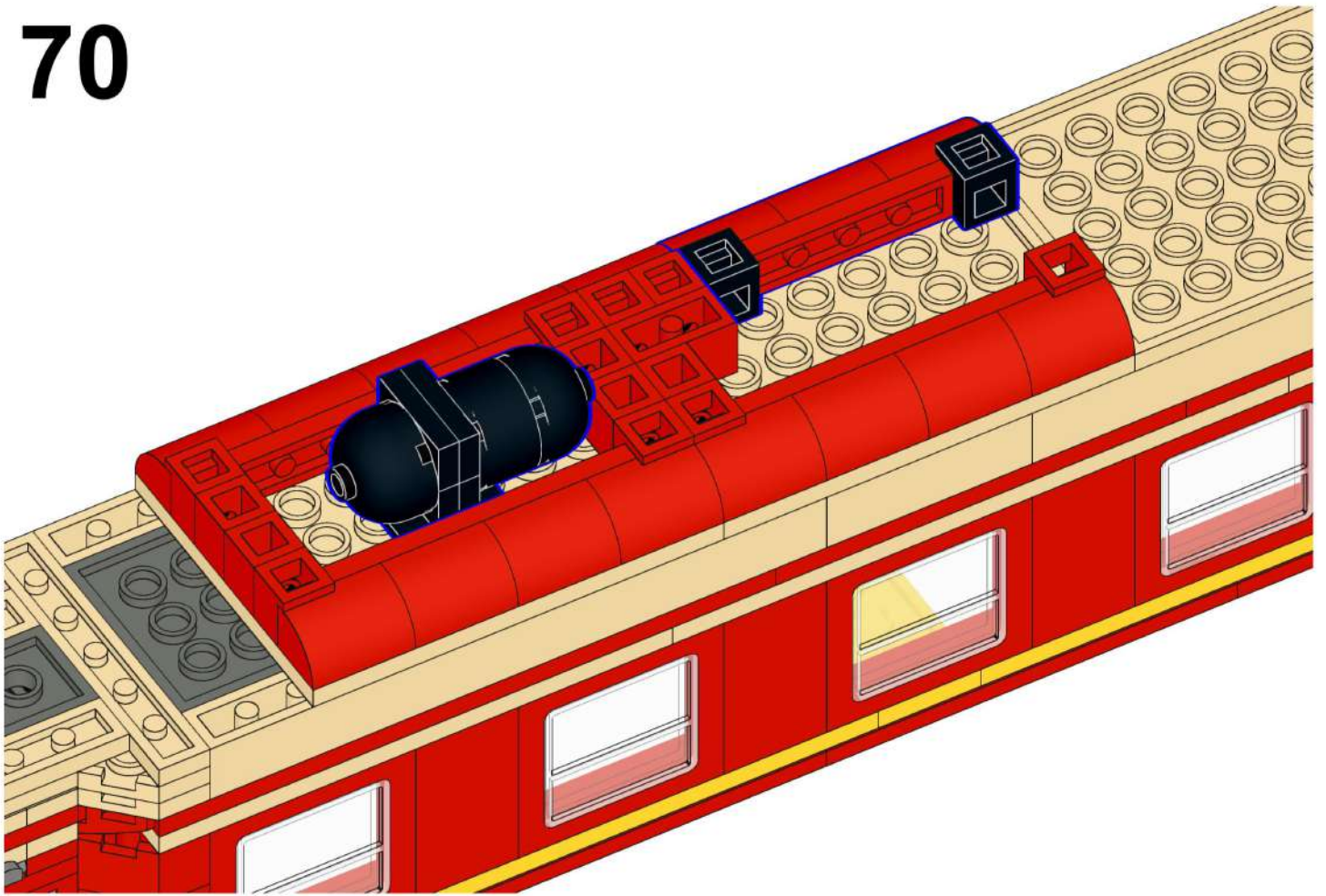

71



1x

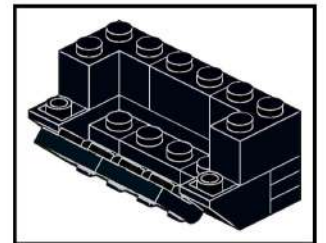
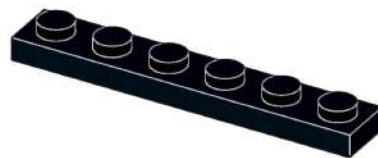

72



2x



2x



1x

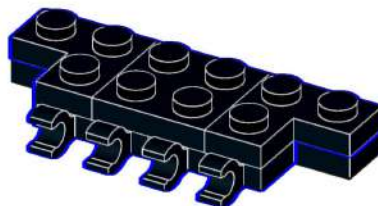

73

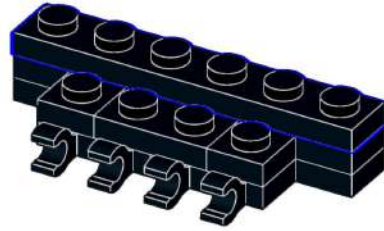

74

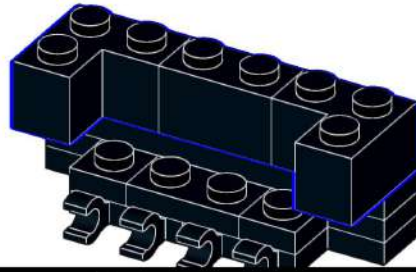
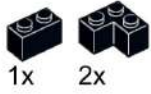

75

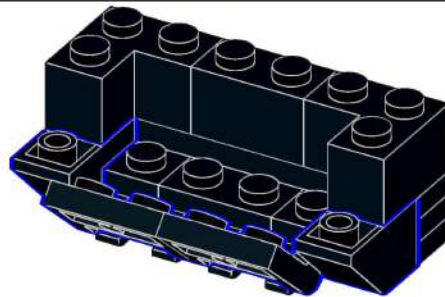

76

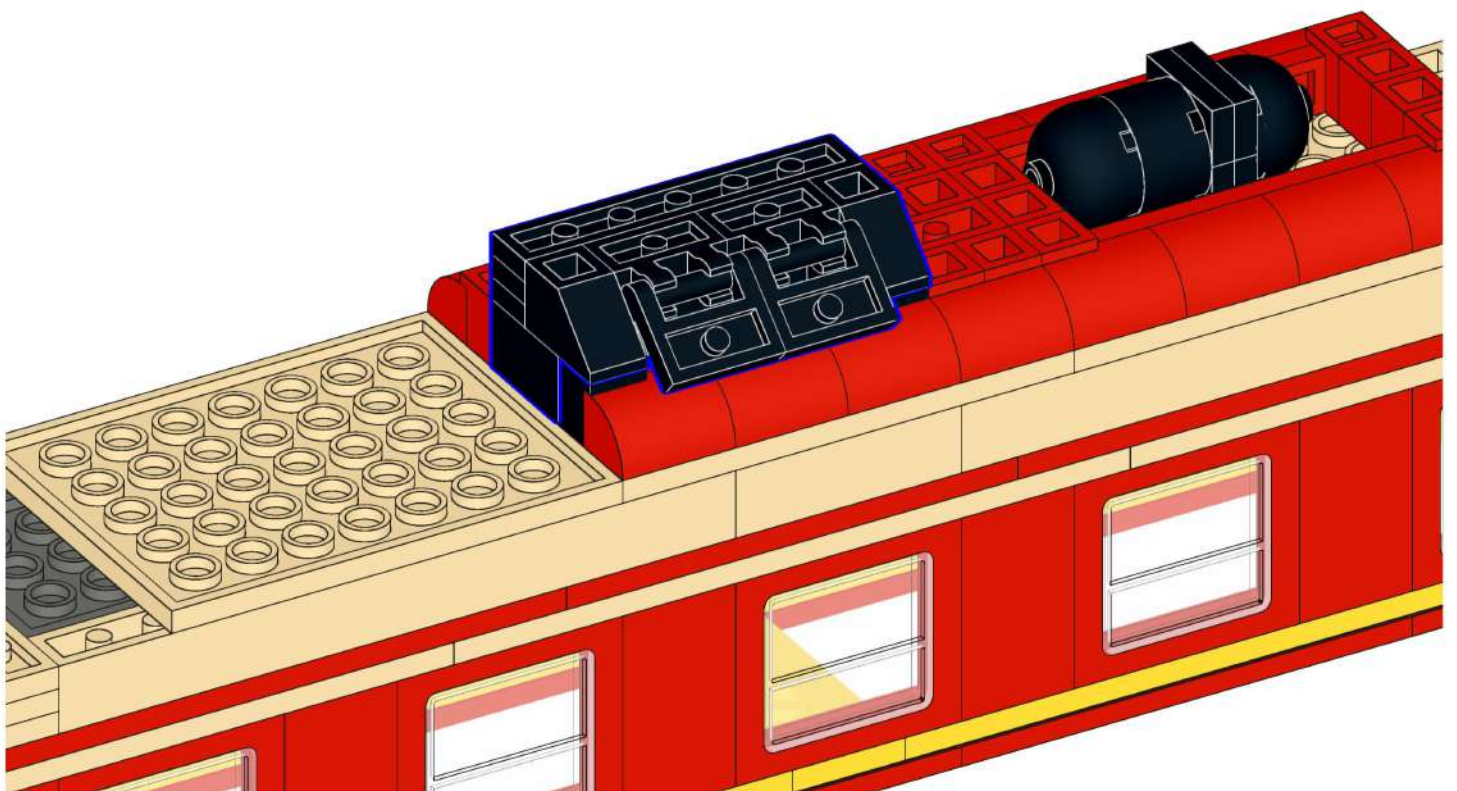

77

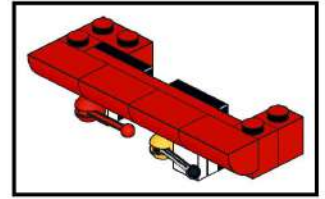
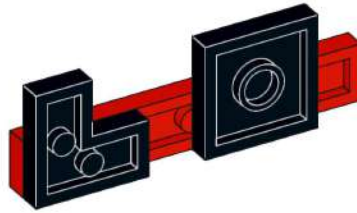
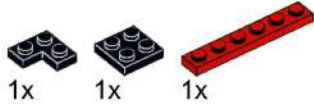

78

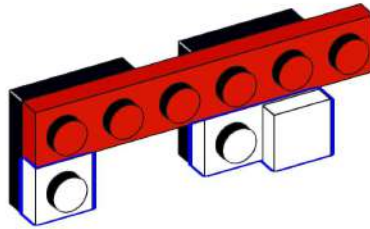
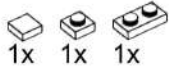

79

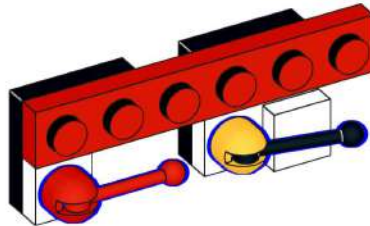

80

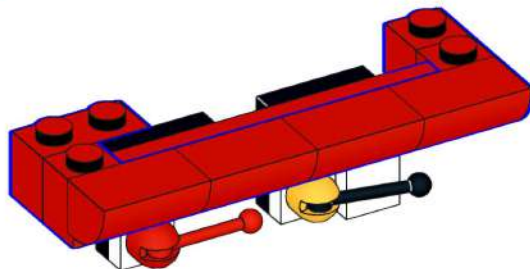
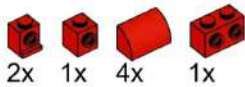

81

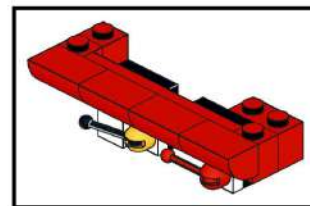
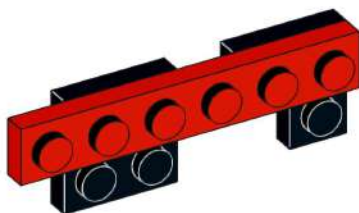
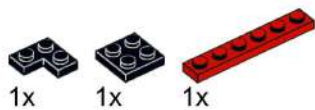

82

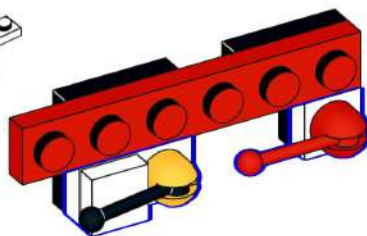
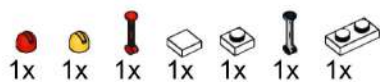

83

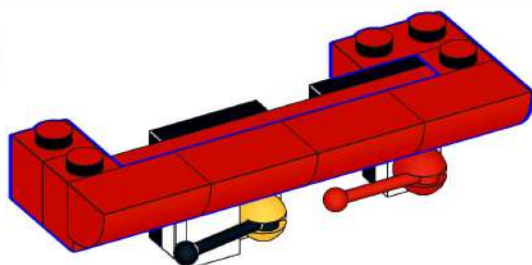
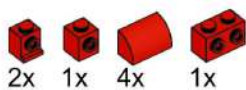

84

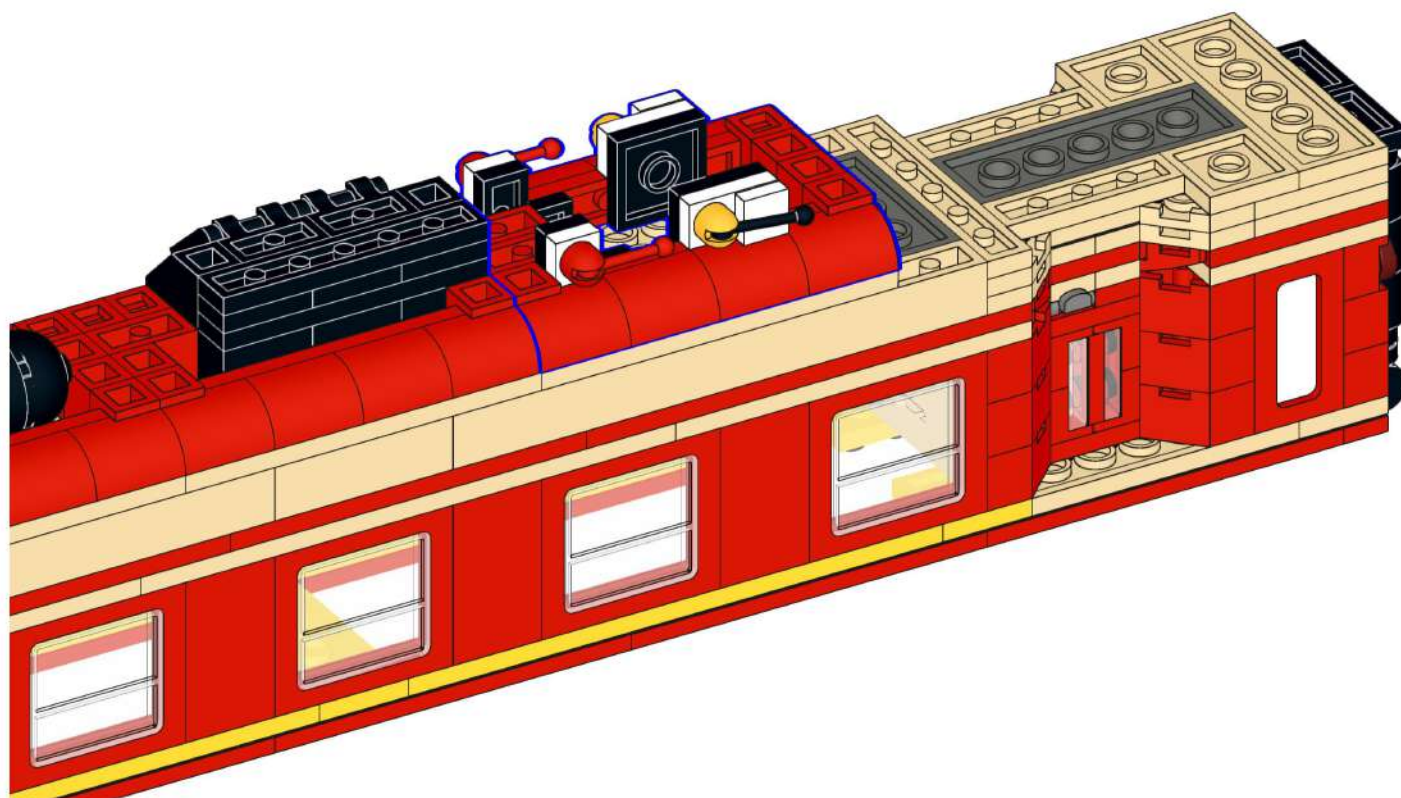

85

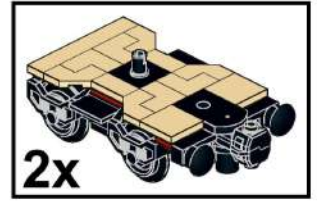
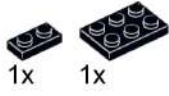

86

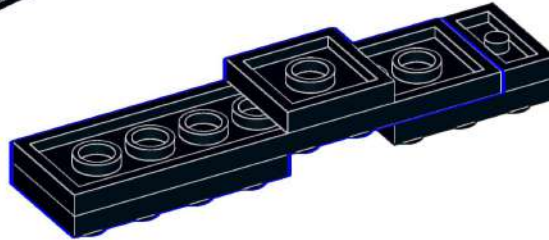

87

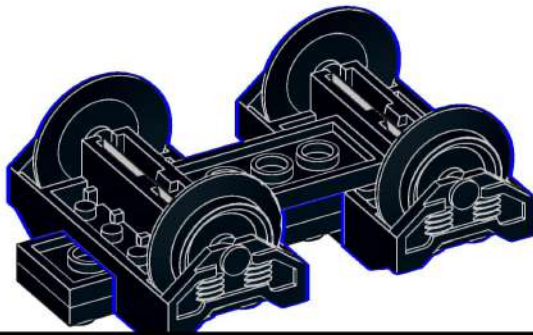
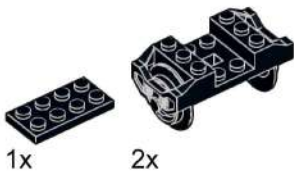

88

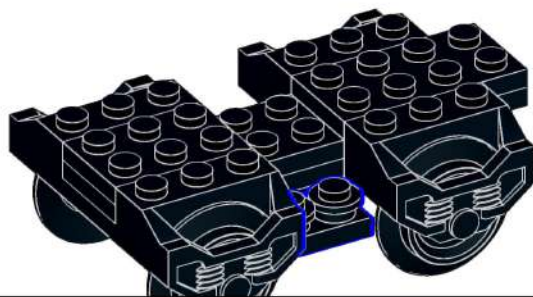

89

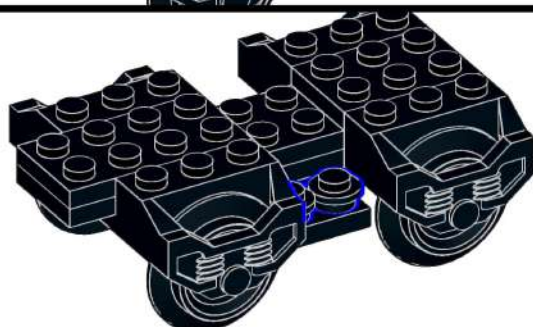

90

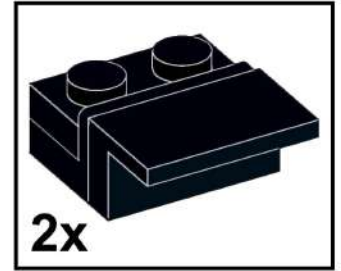
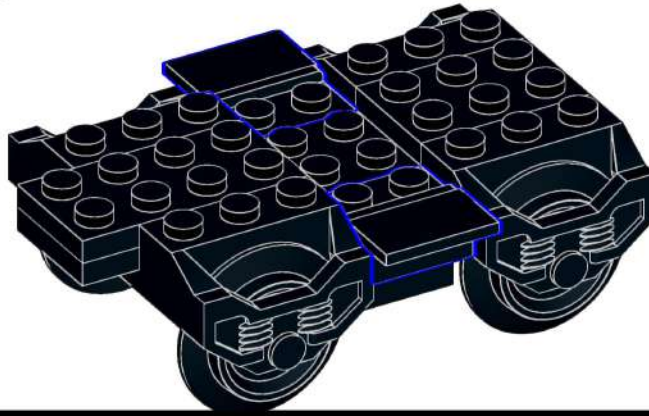

91

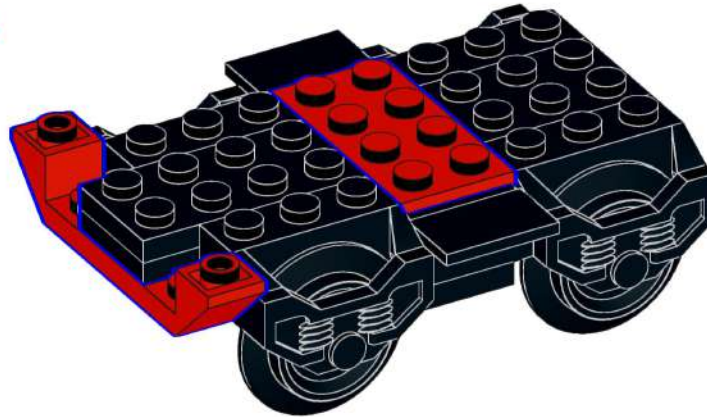
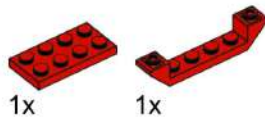

92

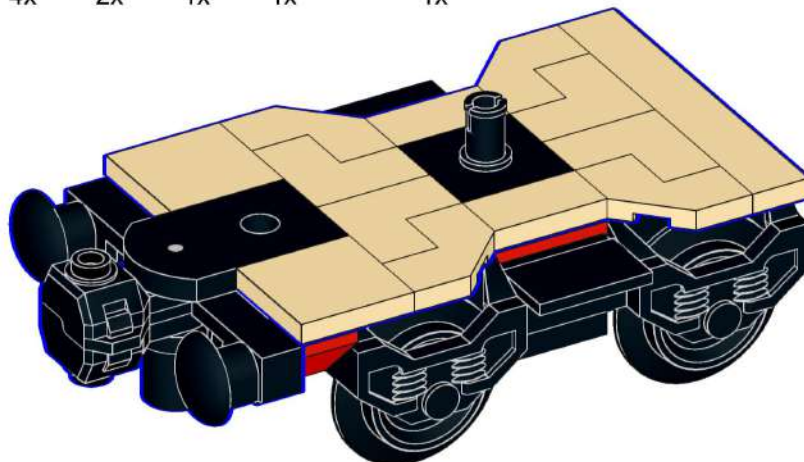
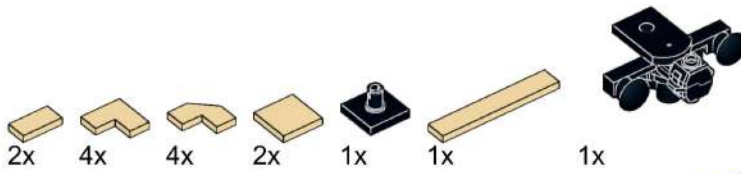

93

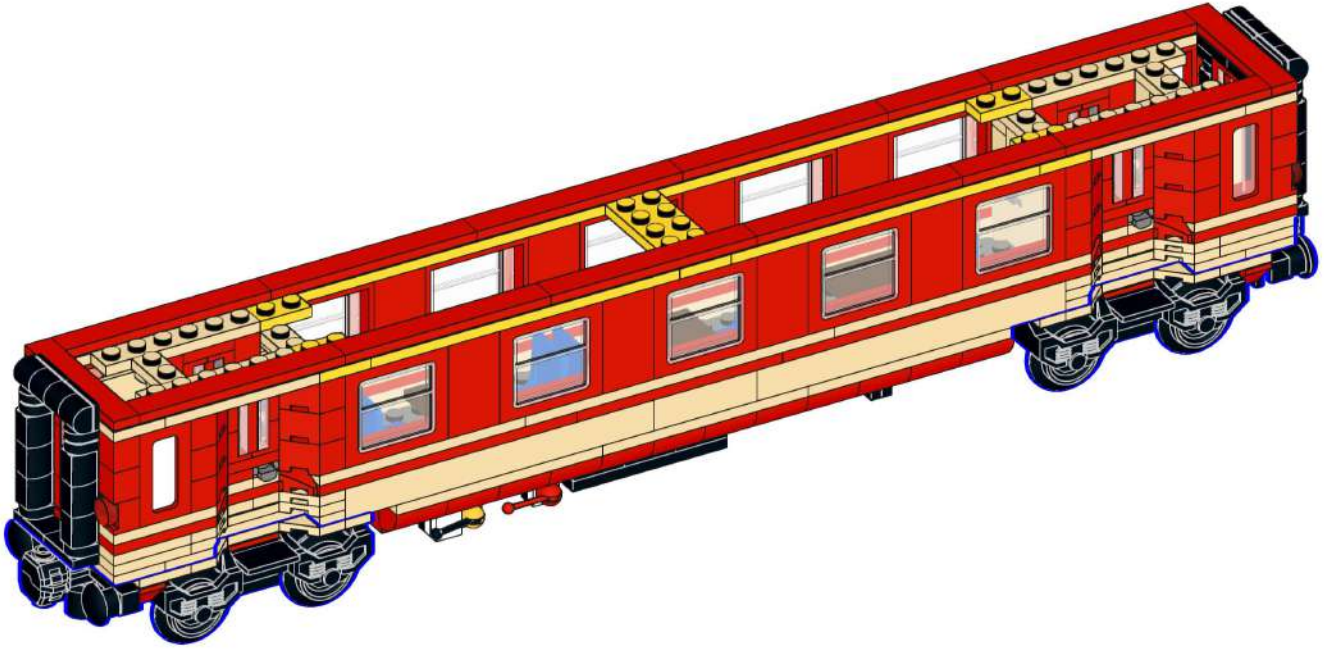

94



4x 1x

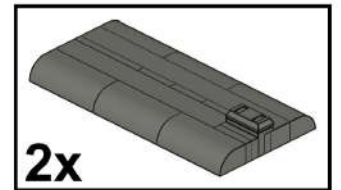
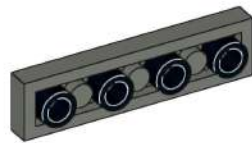

2x

95

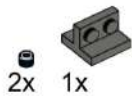

2x 1x

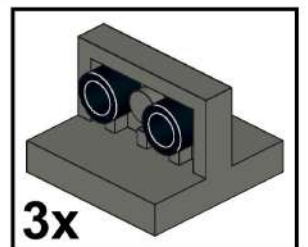
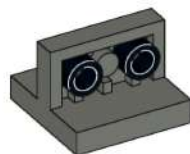

3x

96

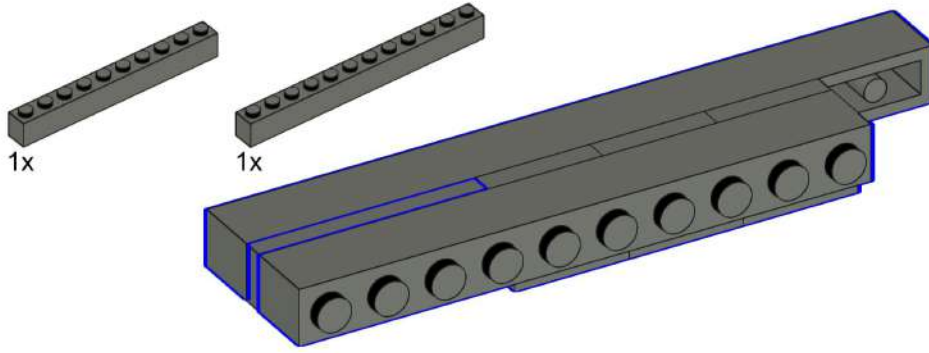

97

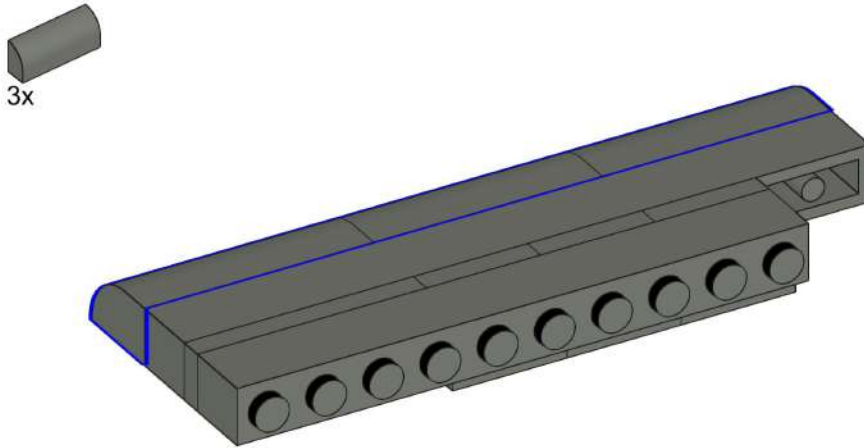

98



99

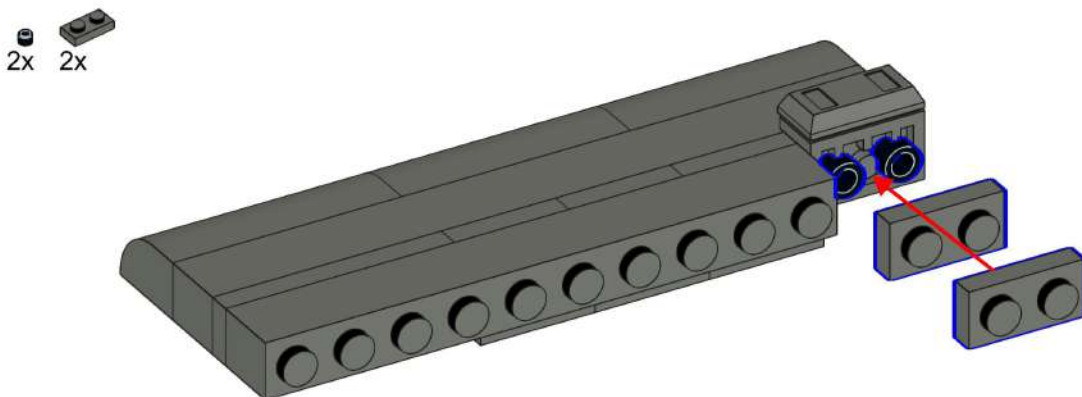

100

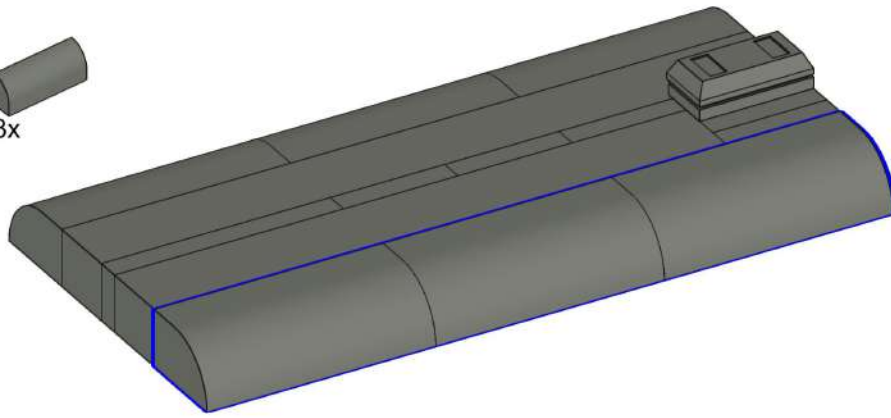

101

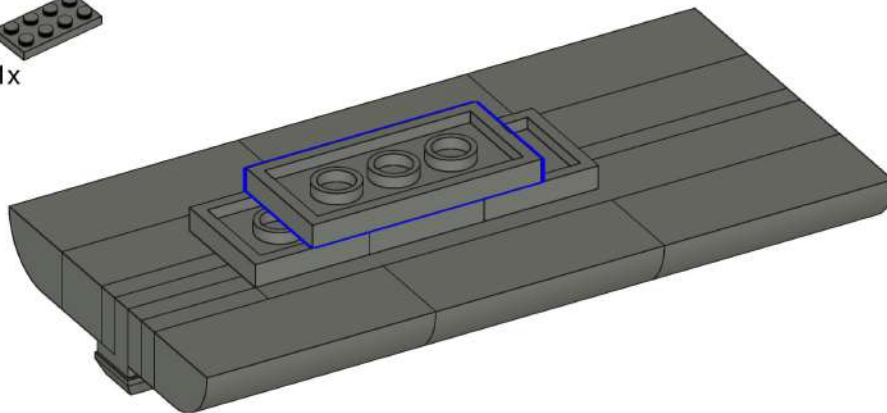

102

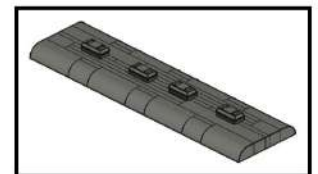
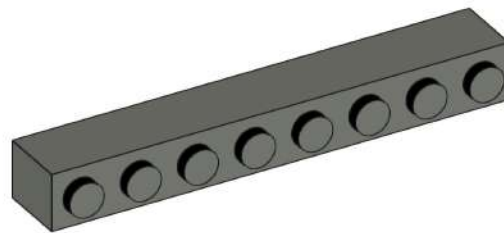
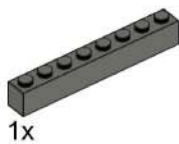

103

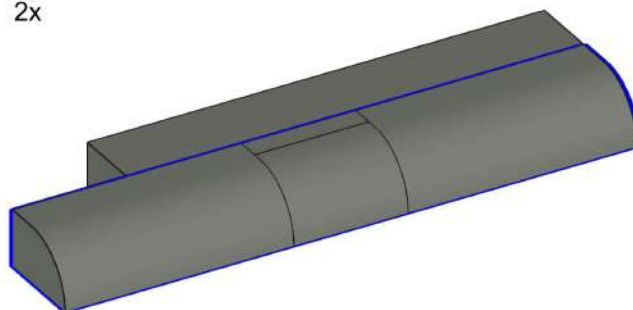
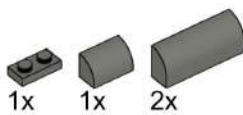

104

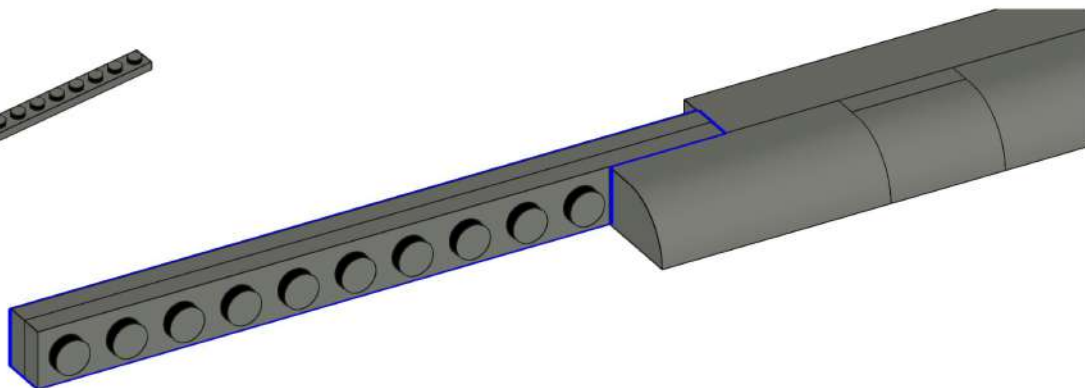

105

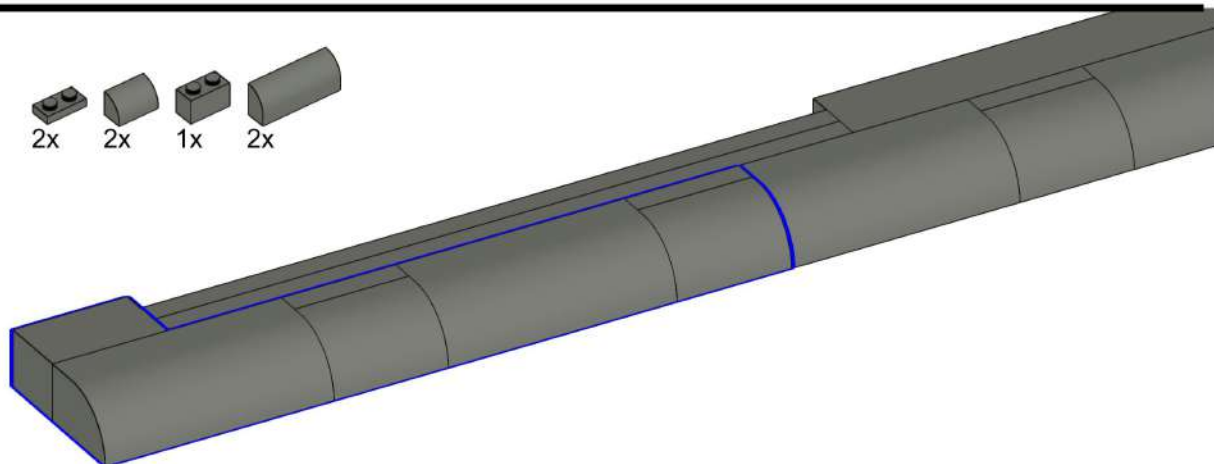
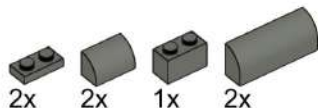

106

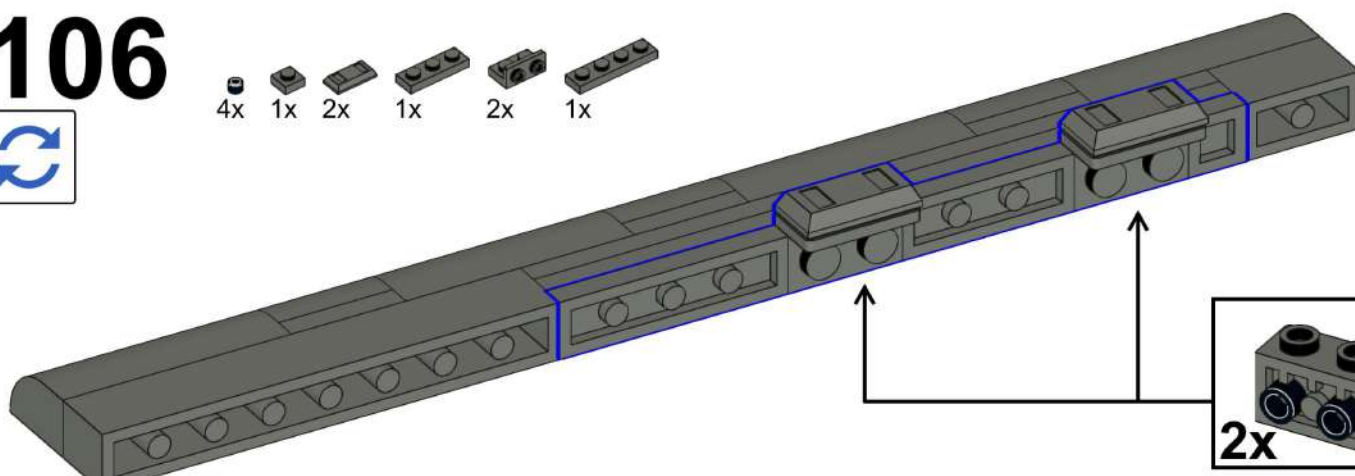

107

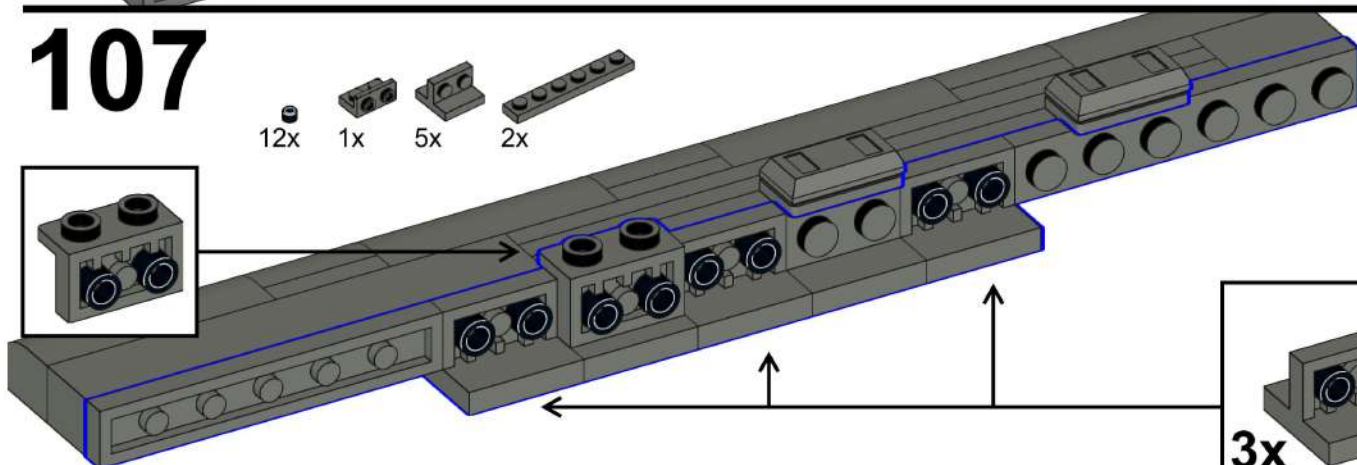
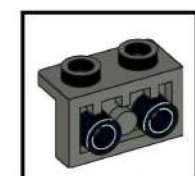
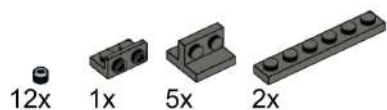

108

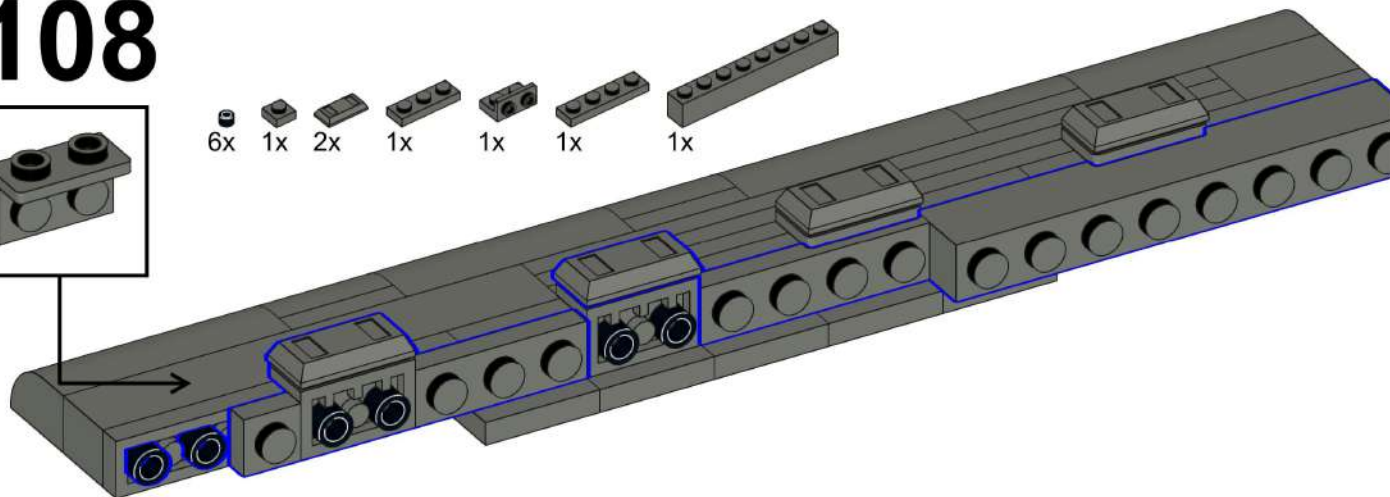
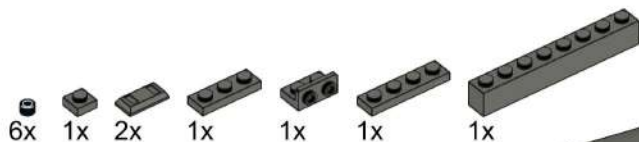
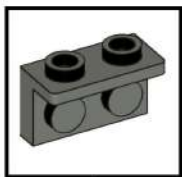

109

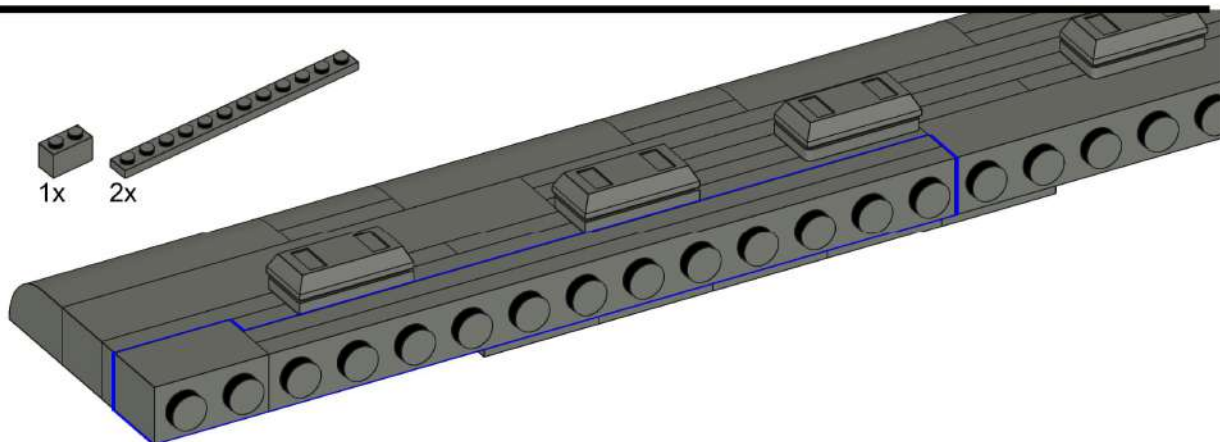

110

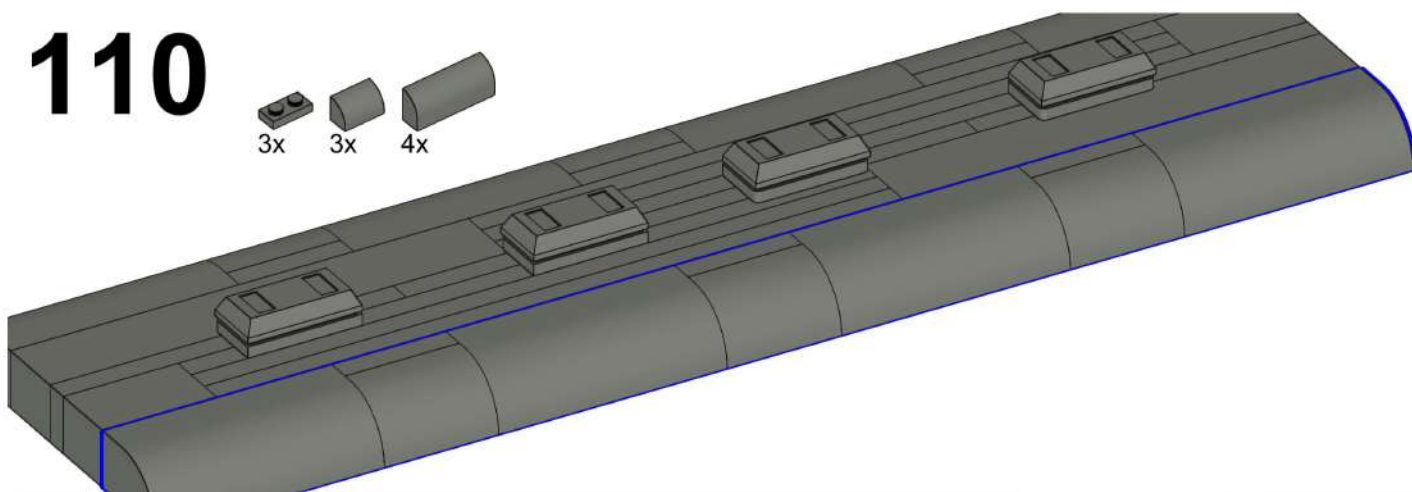
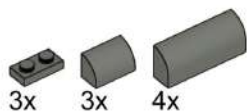

111

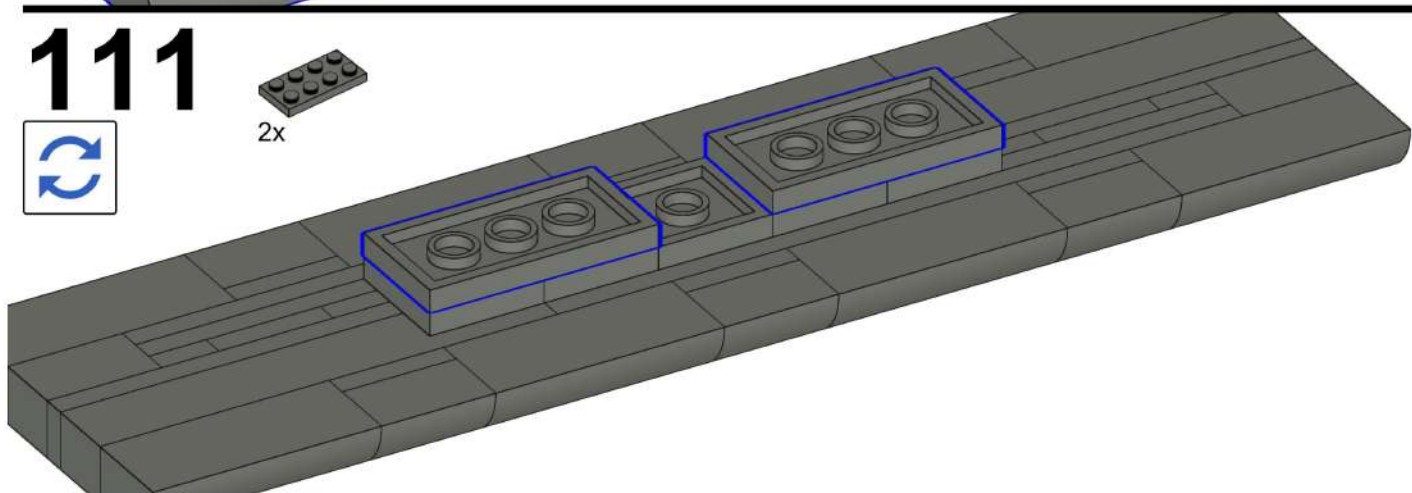

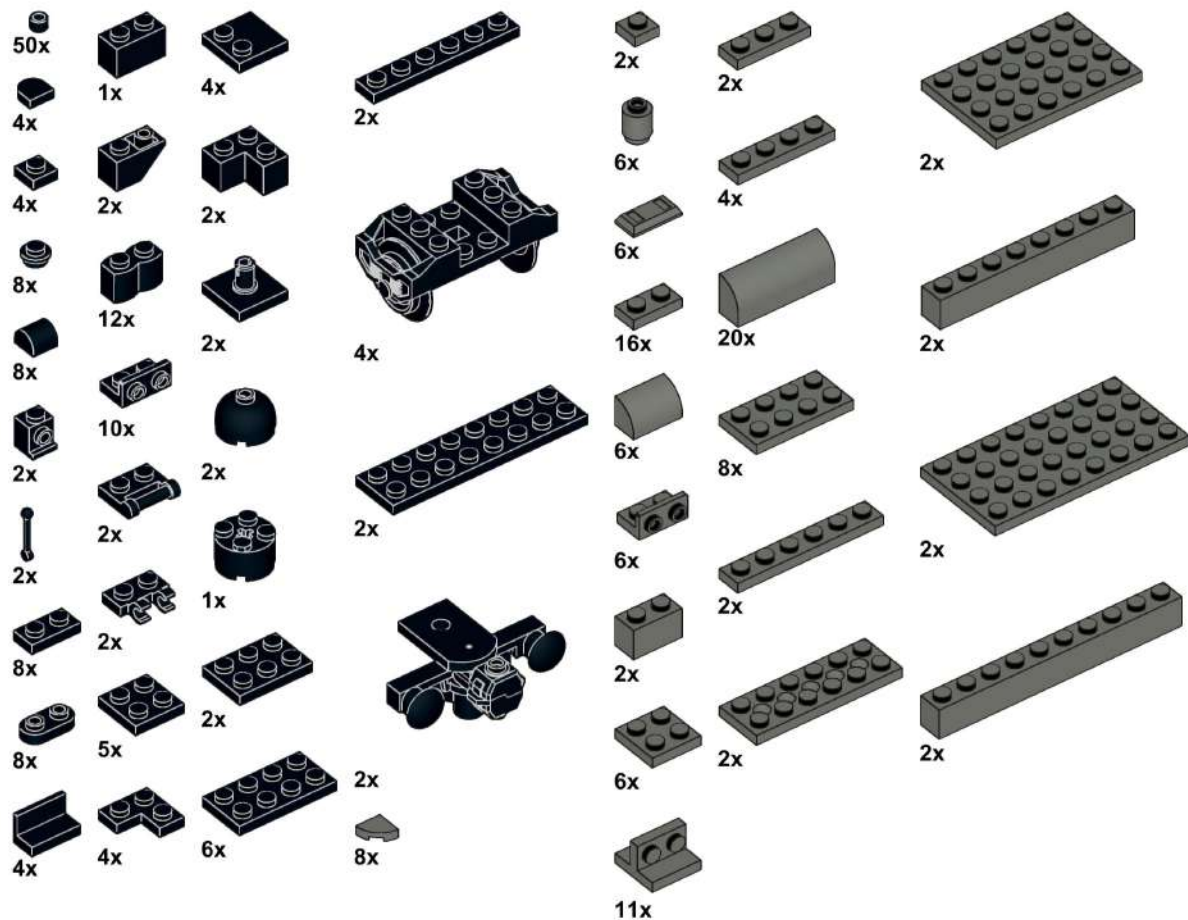

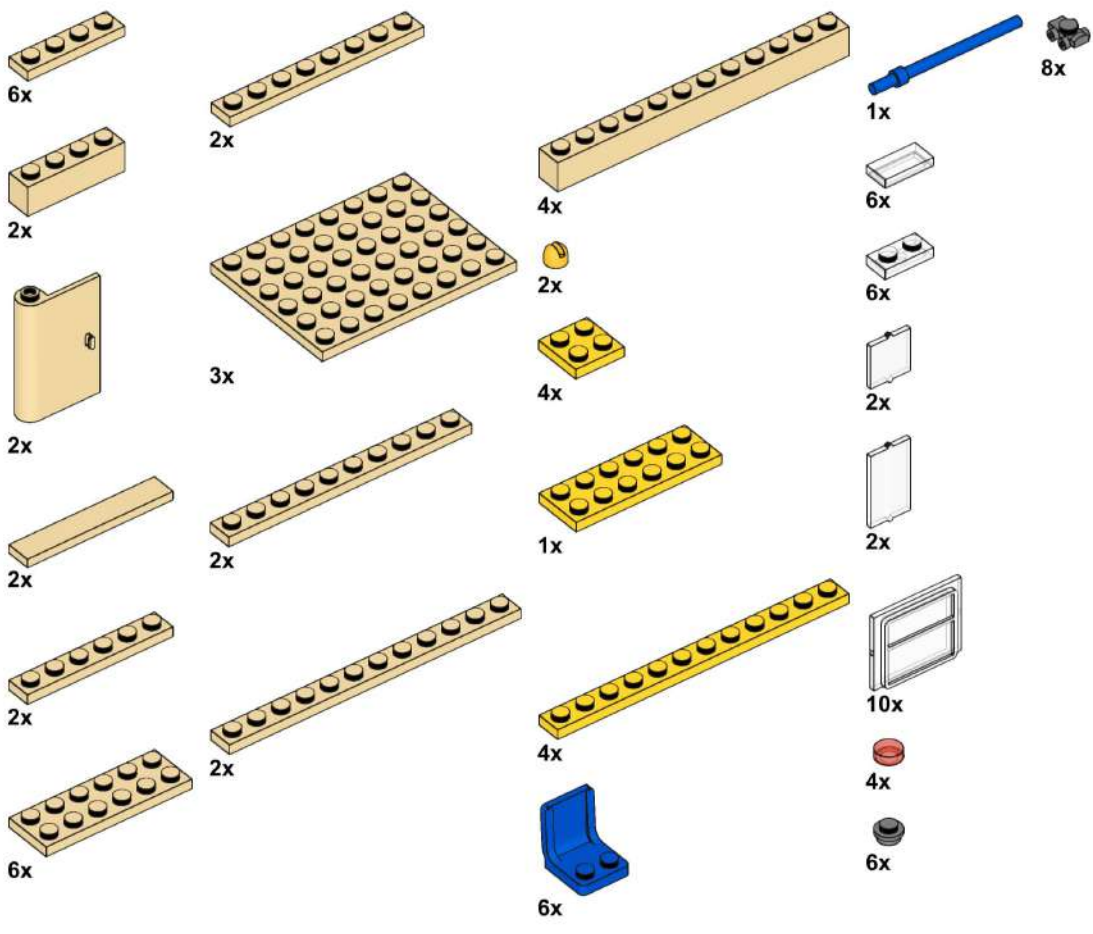
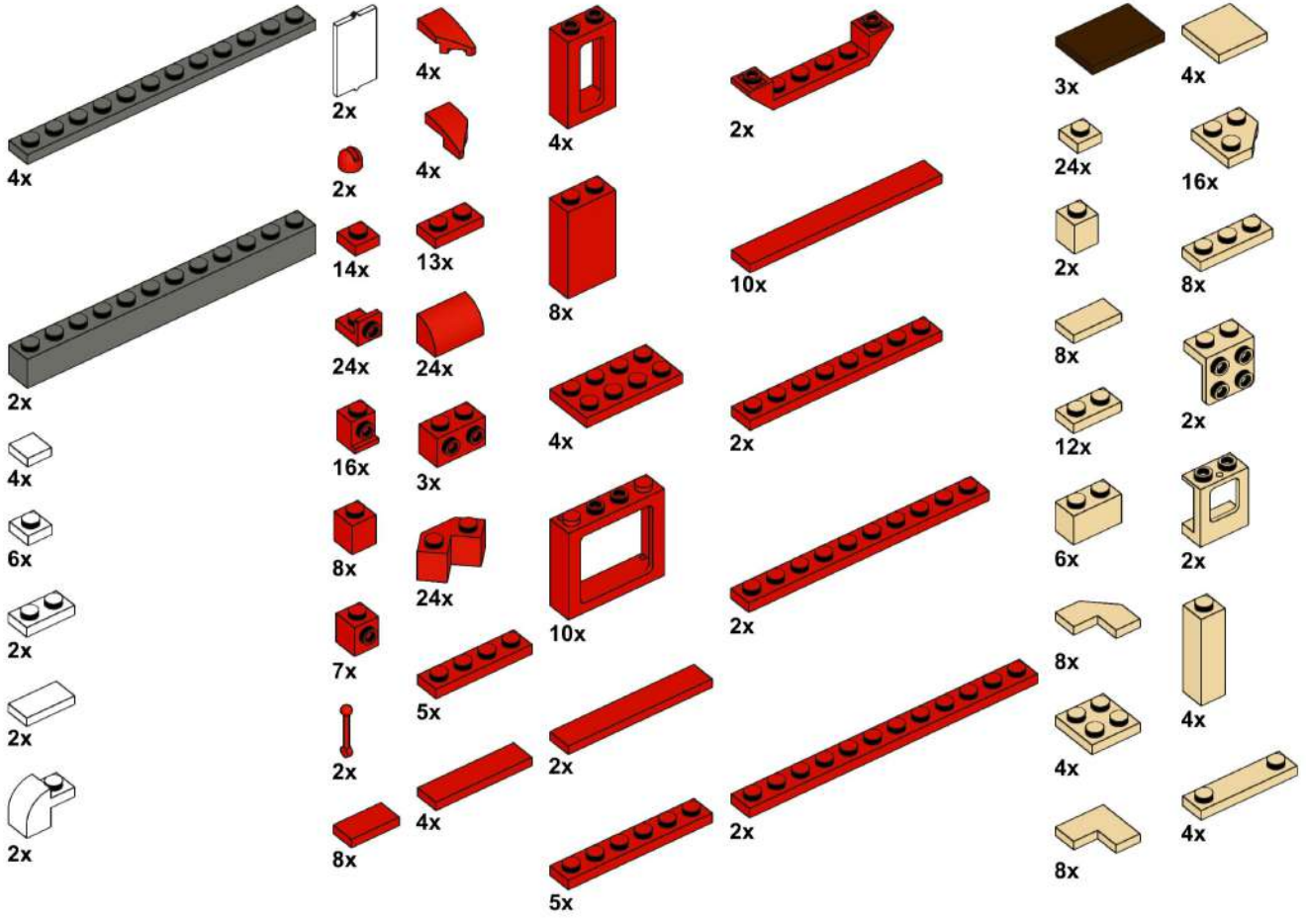



GAILTALBAHN

