



GAILTALBAHN



© Helmut Stattmann



18+ | 725 Teile | Schlieren 2935

Die Schlierenwagen der ÖBB

2. Klasse



© Herbert Pschill

Gattung	Bp (Off, 3ff) Bpz (4ff, 5ff, 6ff)
Nummer	29-35 000 – 259 29-35 300 – 379 29-35 400 – 439 29-35 500 – 569 29-35 600 – 759
Anzahl	260 (Off) 80 (3ff) 40 (4ff) 70 (5ff) 160 (6ff)
Hersteller	SGP/JW (Off, 3ff) JW (4ff, 5ff, 6ff)
Baujahr(e)	1965 – 1970 (Off) 1973 – 1975 (3ff) 1977 – 1978 (4ff) 1979 – 1980 (5ff) 1980 – 1981 (6ff)
Spurweite	1435 mm
vLänge über Puffer	23.700 m
Länge	23.400 m
Höhe	3.700 m
Drehzapfenabstand	17.600 m
Drehgestellachsstand	2.700 m
Höchstgeschwindigkeit	140 km/h
Bremse	Druckluftbremse & Handbremse
Kupplungstyp	Schraubenkupplung

Die Schlierenwagen der ÖBB



© Helmut Stattmann

Die Schweizerische Bundesbahnen (SBB) beschafften ab 1956 unter der Bezeichnung „Einheitswagen I“ eine neue Generation an 23,7 m langen Reisezugwagen. Neben 1. und 2. Klasse-Wagen wurden auch Speisewagen, Gepäckwagen und Steuerwagen gefertigt. Durch den Erfolg in der Schweiz wurden die Österreichischen Bundesbahnen (ÖBB) auf diese Wagen aufmerksam.

In der Folge bestellte die ÖBB 1963 bei den heimischen Firmen Simmering-Graz-Pauker (SGP) und Jenbacher Werken verschiedene Ausführungen von Waggons nach dem Vorbild der SBB Einheitswagen I. Statt Wagen aufwendig und langwierig selbst zu entwickeln, griffen die Hersteller auf Lizenzfertigungen zurück, die von den Herstellern Schweizerische Industriegesellschaft Neuhausen (SIG) und der Schweizerischen Waggonfabrik gewährt wurden. Da letztere ihren Firmensitz in der Schweizer Stadt Schlieren hat, setzte sich in Österreich der Name „Schlierenwagen“ für diese Type durch. Zwischen 1965 und 1981 wurden insgesamt 800 Stück an die ÖBB geliefert. In den ersten Jahren wurden die Wagen noch in Tannengrün mit weiß-aluminiumfarbigen Dach ausgeliefert. Ab 1975 erfolgte die Umstellung auf die Farbkombination Blutorange und Elfenbein. Die Wagen waren für 140 km/h zugelassen und konnten auch international für Fahrten in die Schweiz, nach Deutschland und nach Italien eingesetzt werden.

Für die ÖBB wurden 1. Klasse-Wagen, gemischte 1. und 2. Klasse-Wagen, 2. Klasse-Wagen, 2. Klasse-Wagen mit Gepäckabteil und 2. Klasse-Wagen mit Buffet gefertigt. Die 1. Klasse-Waggons verfügten wegen dem komfortableren vergrößerten Sitzabstand über weniger Sitzreihen als die Waggons der 2. Klasse, was auch an der Fensteranzahl erkennbar ist. In den folgenden Jahren entstanden durch Umbauten weitere Subtypen, u. A. auch für den Fahrradtransport.

Nach der Auslieferung wurden die damals neuen Wagen nur im hochwertigen internationalen Fernverkehr eingesetzt. Sukzessive verlagerte sich der Einsatz im Lauf der Jahre zunächst in den innerösterreichischen D- und Eilzugverkehr, bis die Wagen schlussendlich im Regionalverkehr eingesetzt wurden.

Schlierenwagen wurden von ÖBB am Ende ihrer Einsatzzeit auch ins Ausland abgegeben, u. a. in den Kosovo und nach Ungarn (GySEV und MÁV). Der größte Teil wurde jedoch verschrottet.

Derzeit sind Schlierenwagen in Österreich noch bei der Österreichischen Gesellschaft für Eisenbahngeschichte (ÖGEG), dem Verein der Eisenbahnfreunde Lienz (EBFL), der Regiobahn und dem Verein Neue Landesbahn vorhanden und kommen im Ausflugs- und Sonderverkehr zum Einsatz.



1

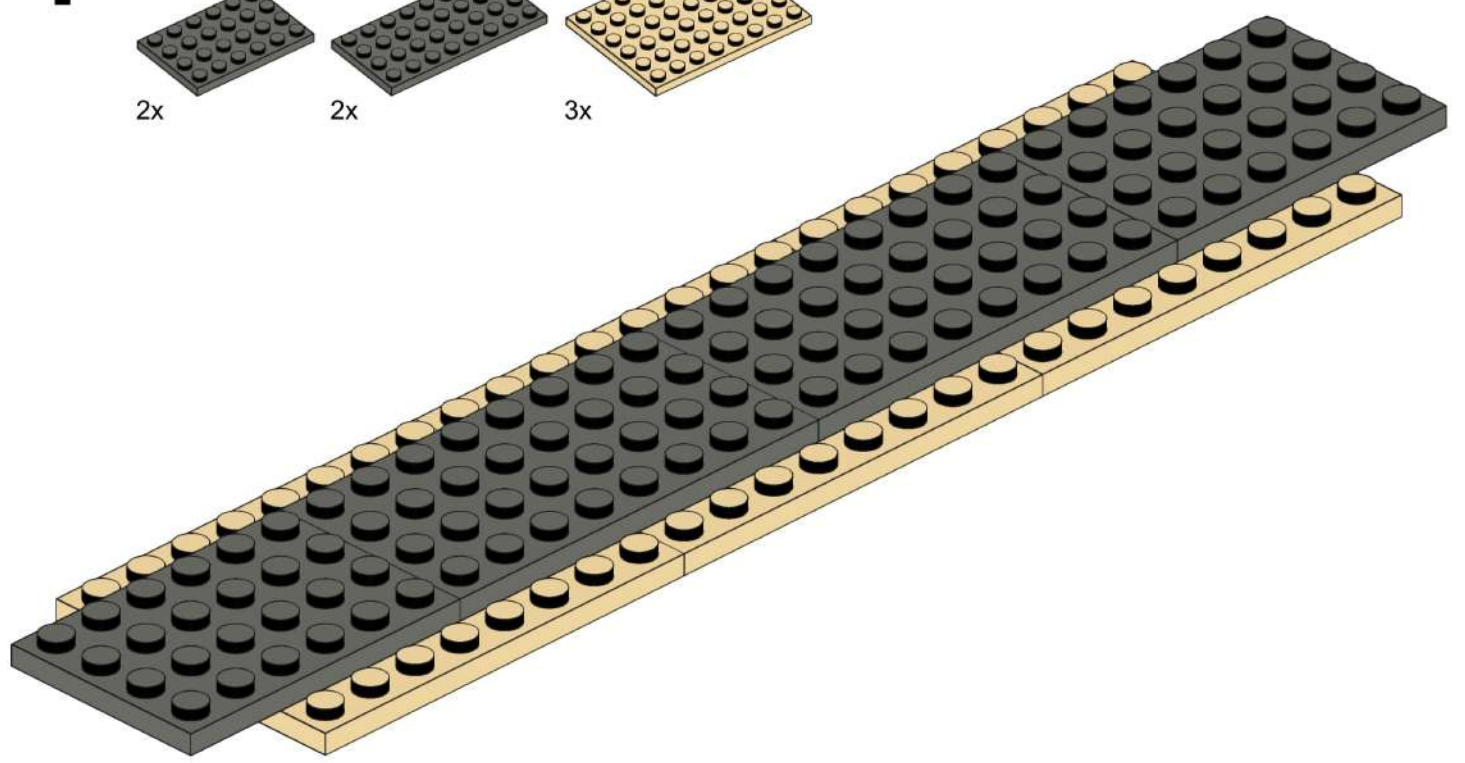
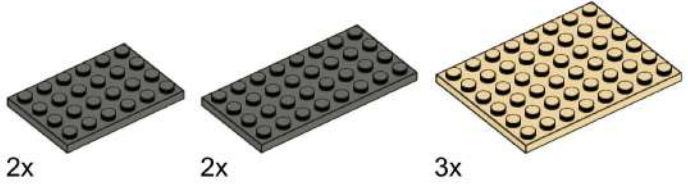

2



1x

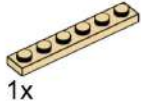

1x



1x

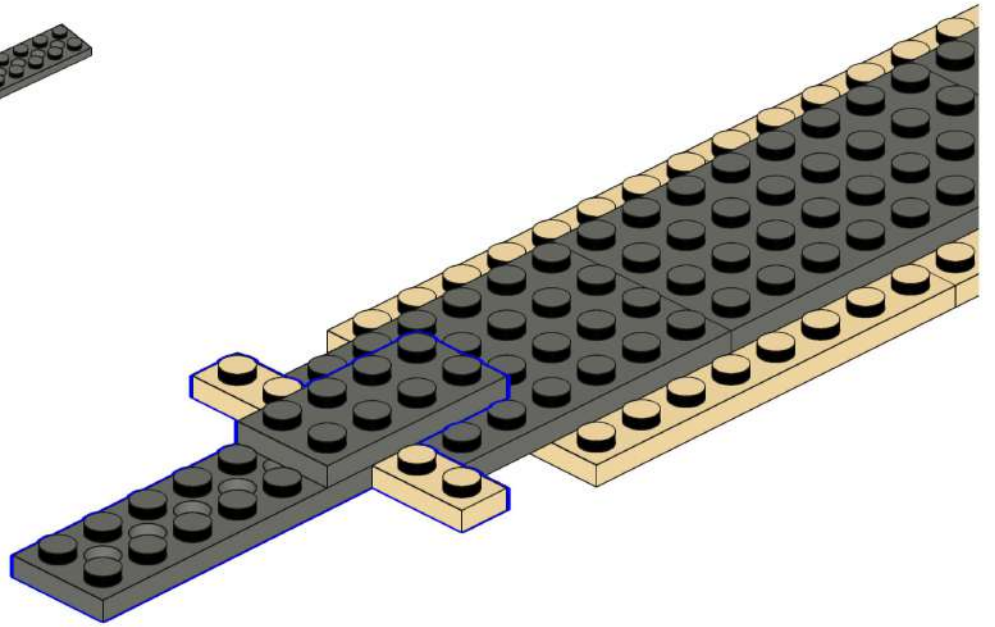

3

4x



2x



2x

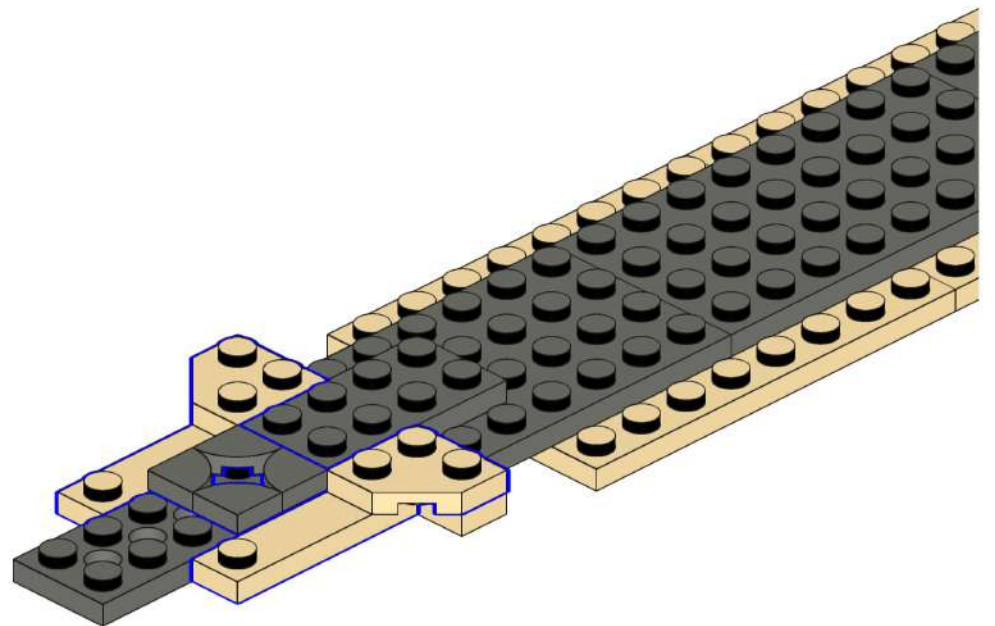

4

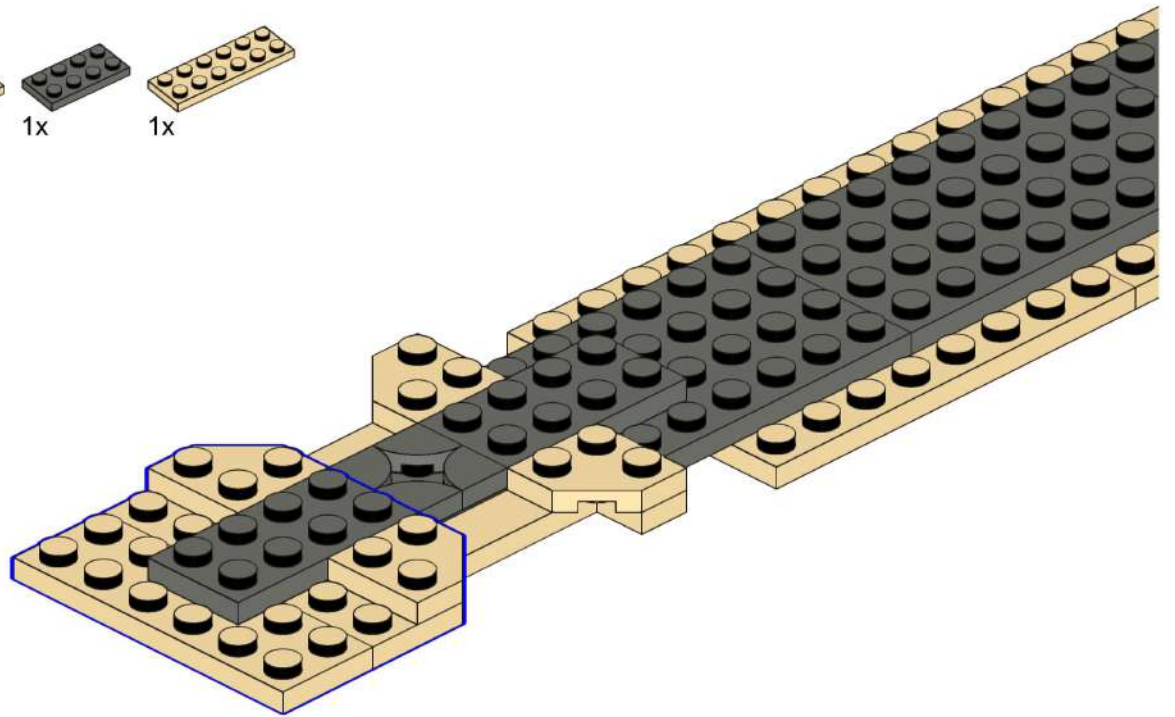
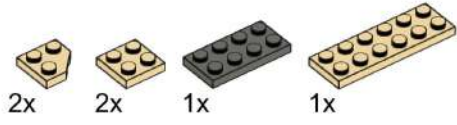

5

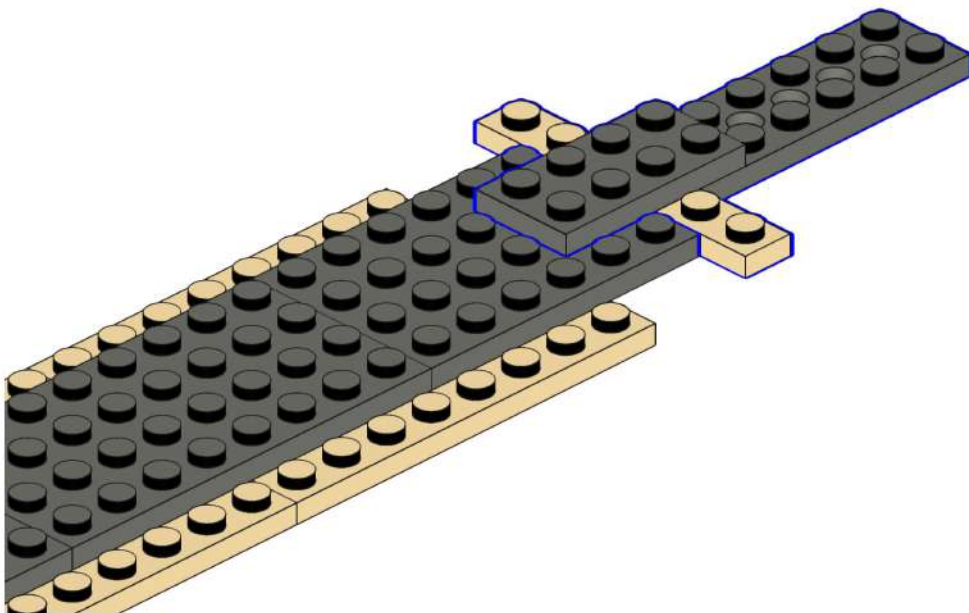
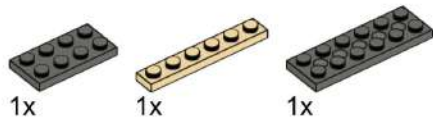

6

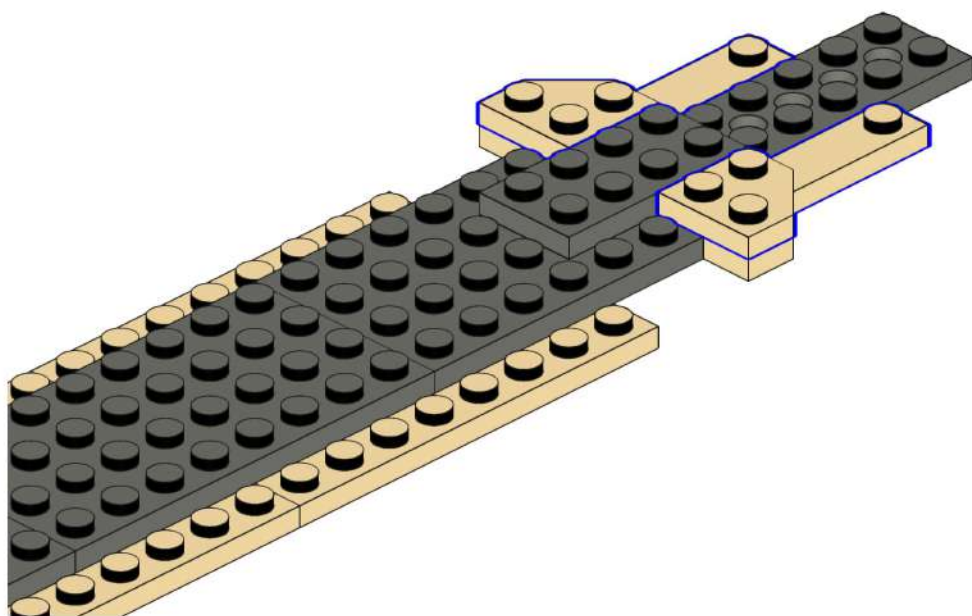
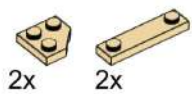

7

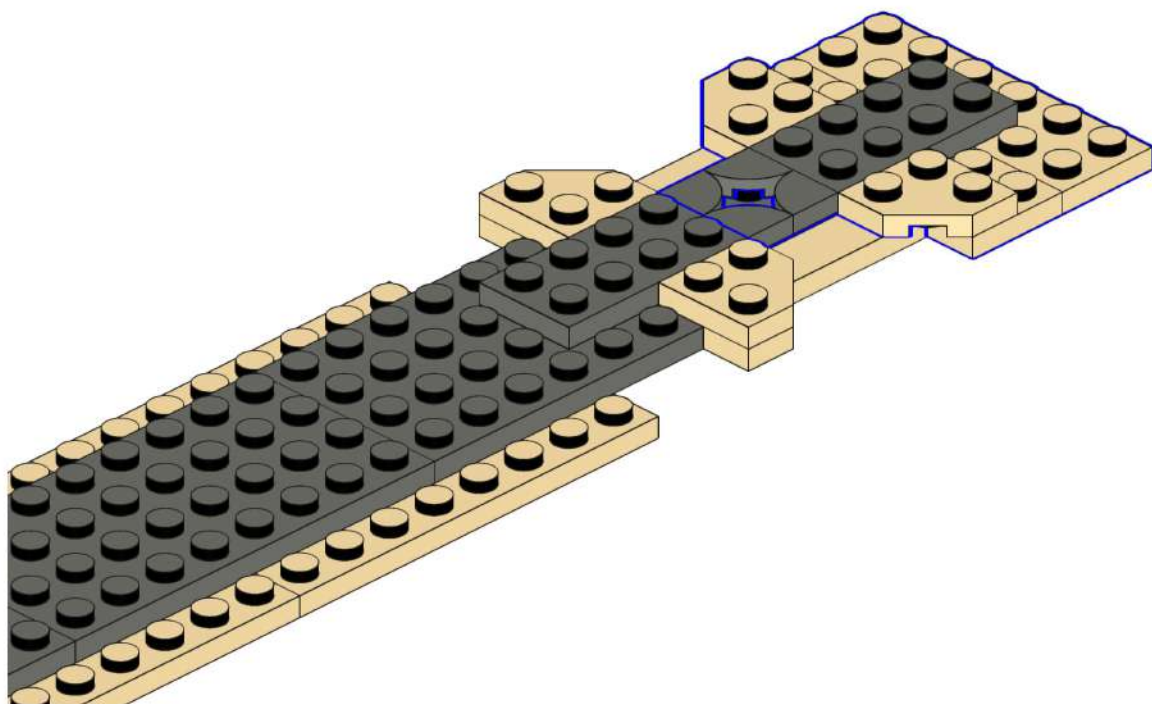
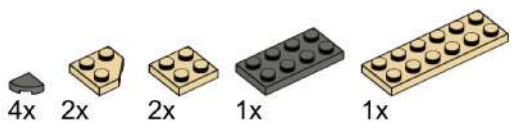

8



4x

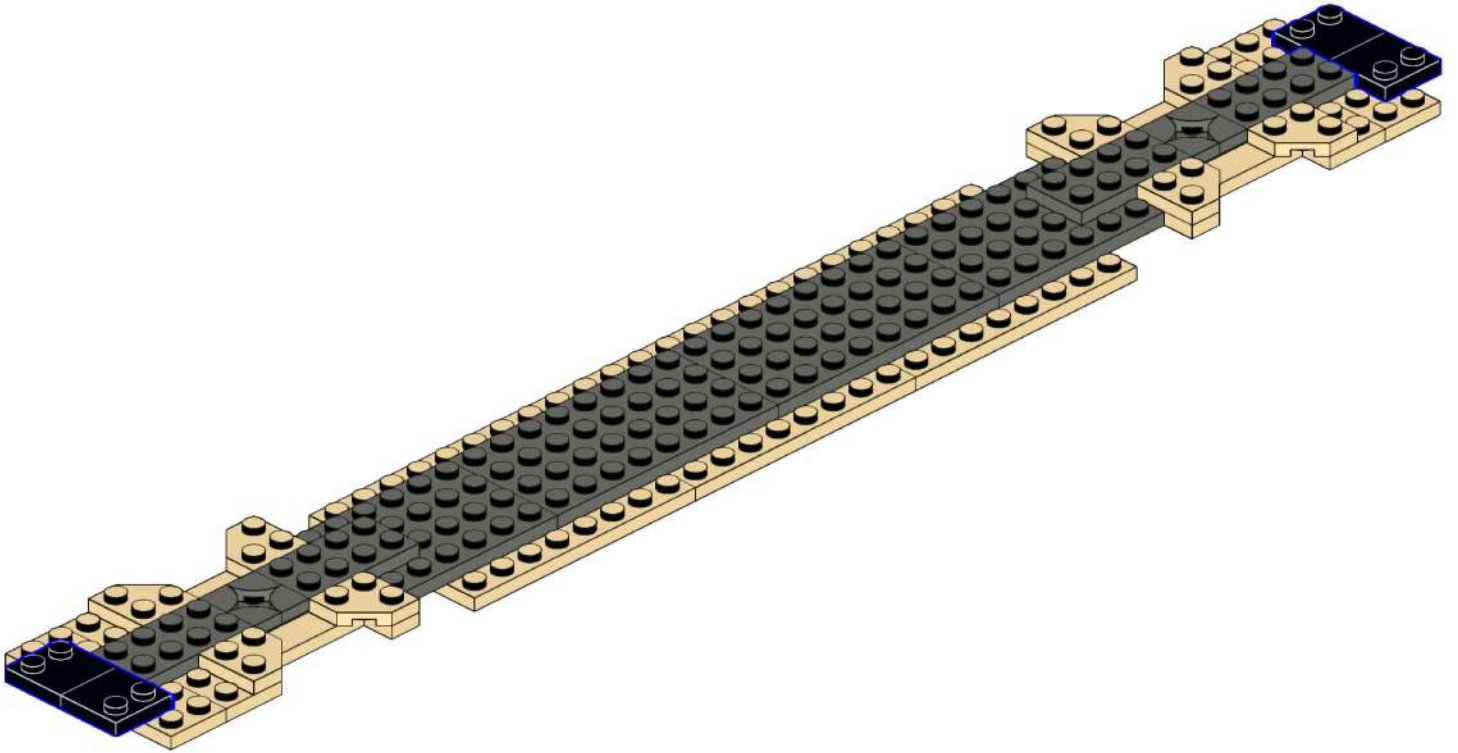

9



8x

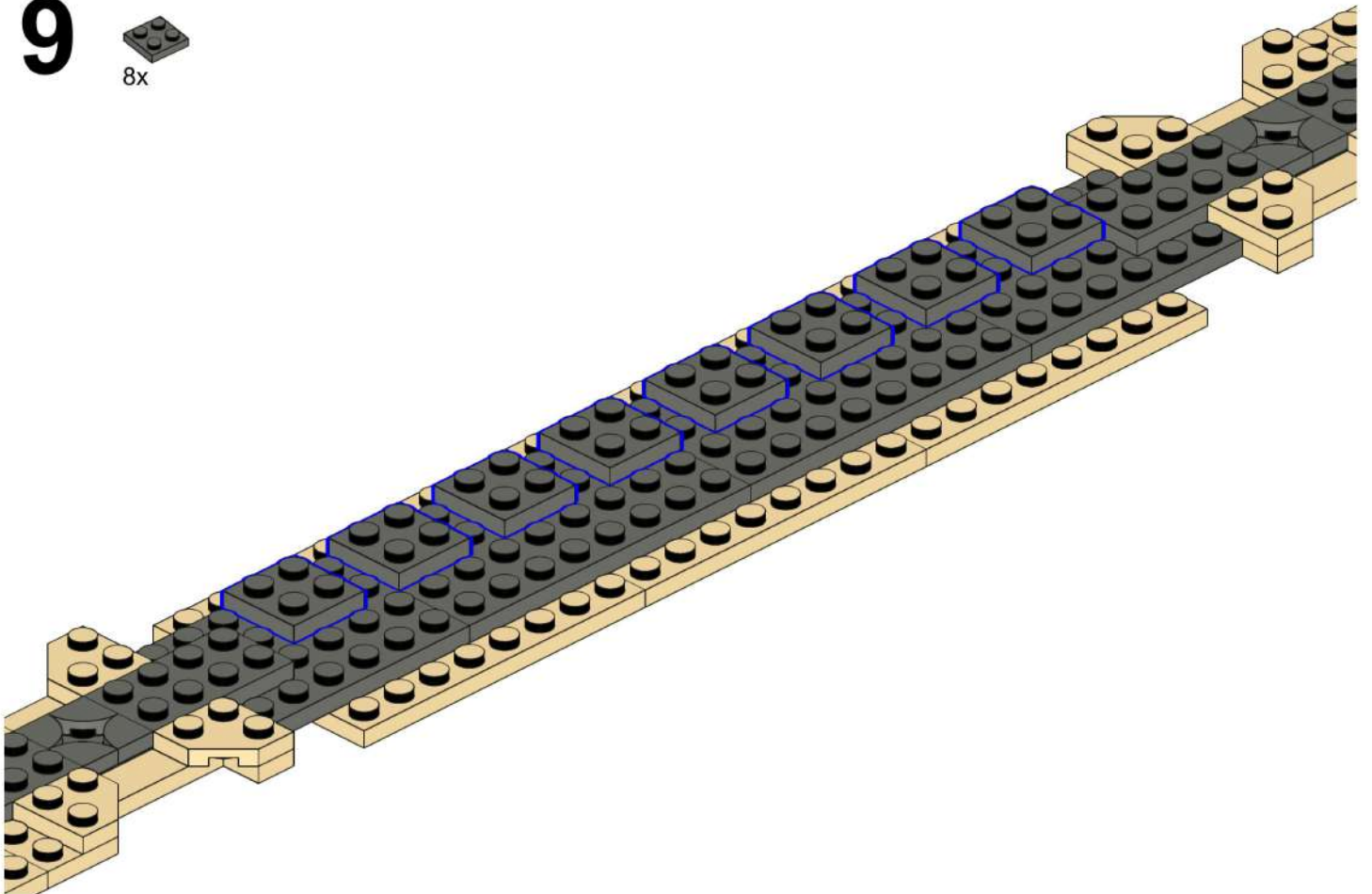

10

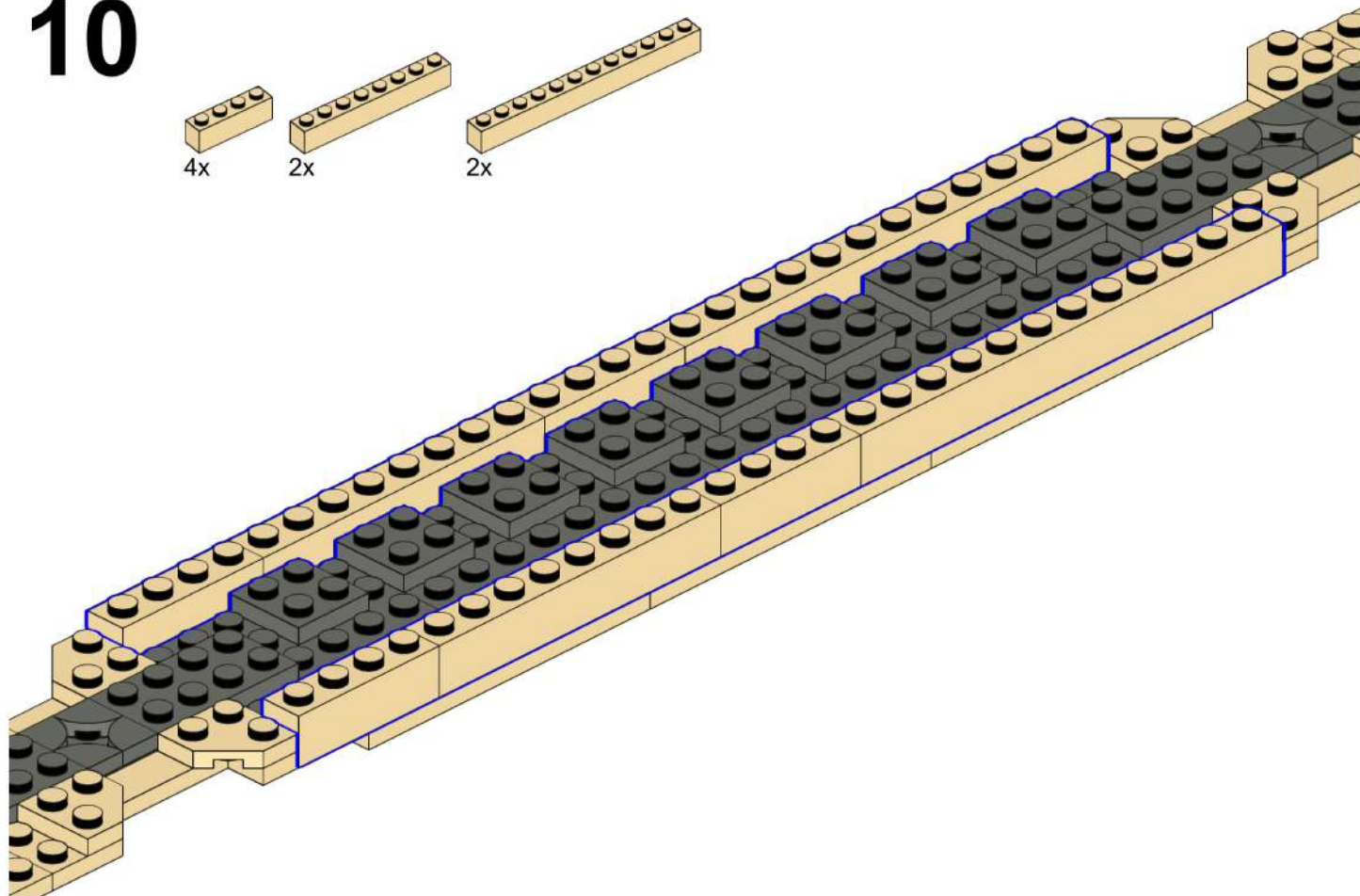
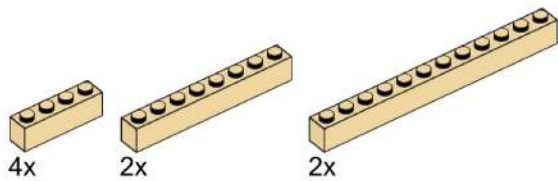

11

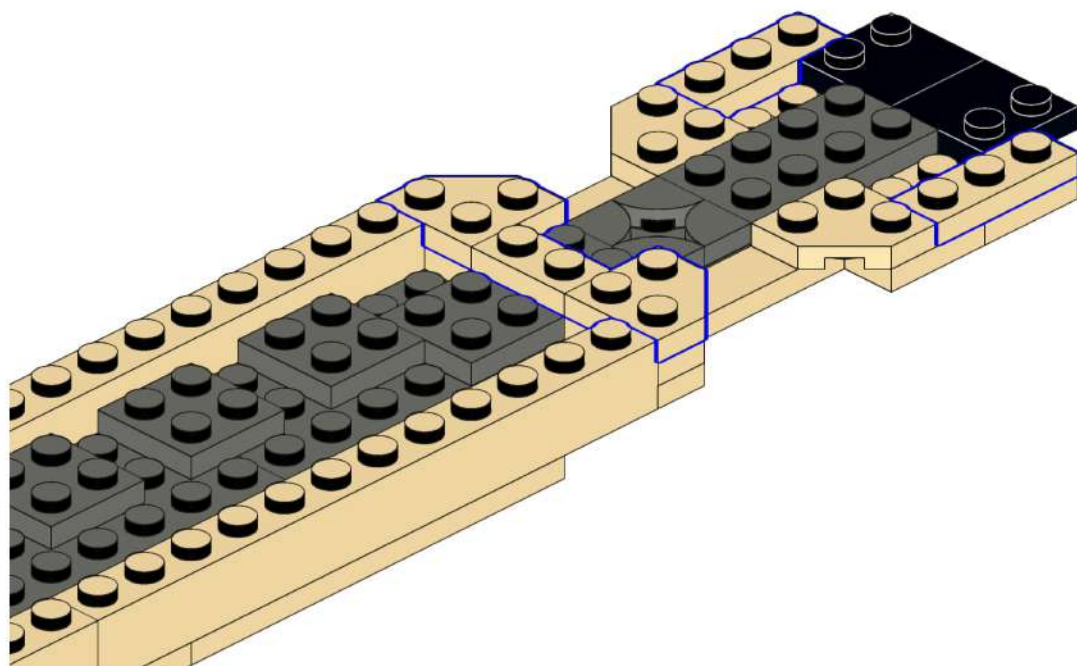

12

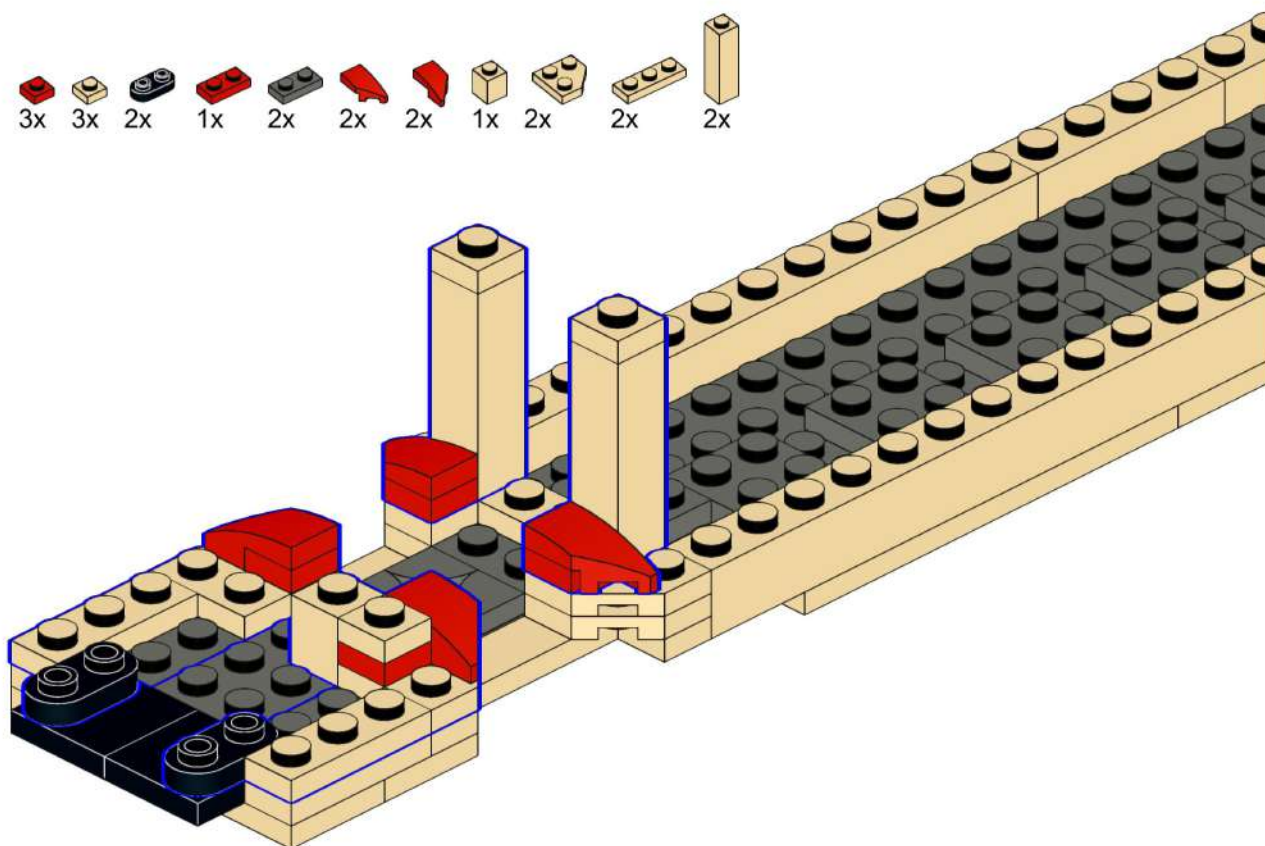
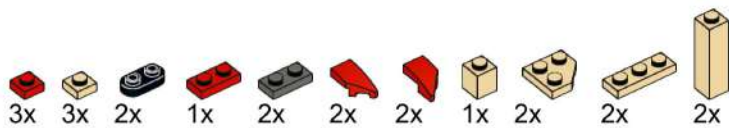

13

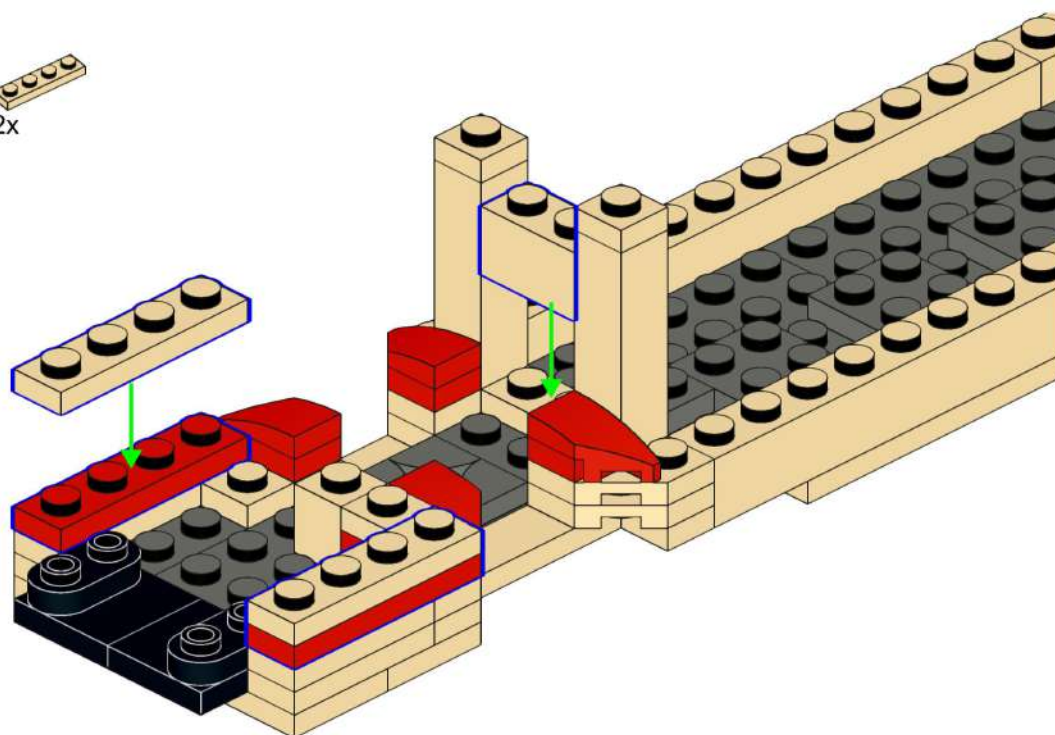

14

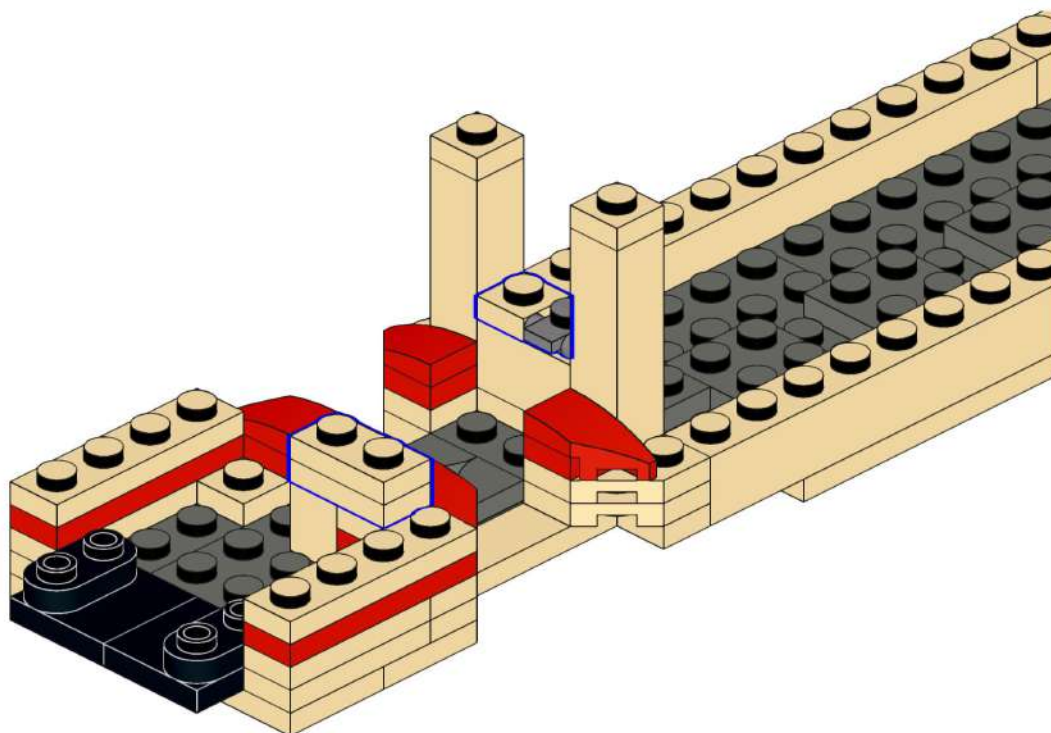
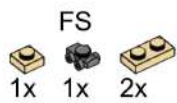

15

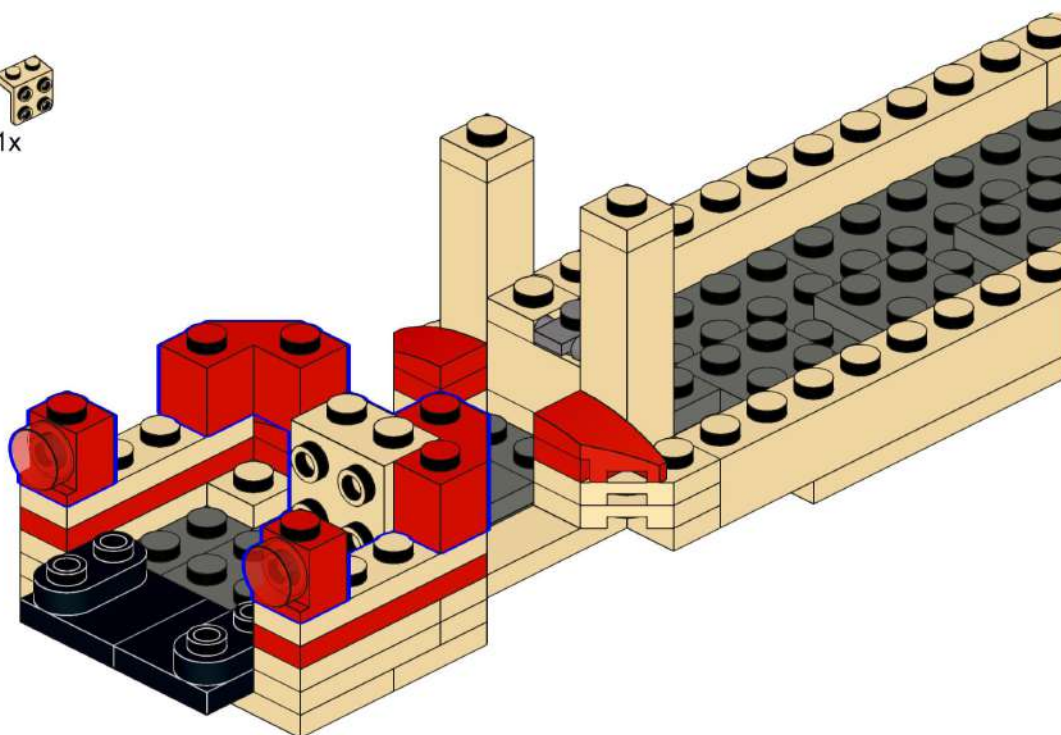
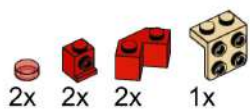

16

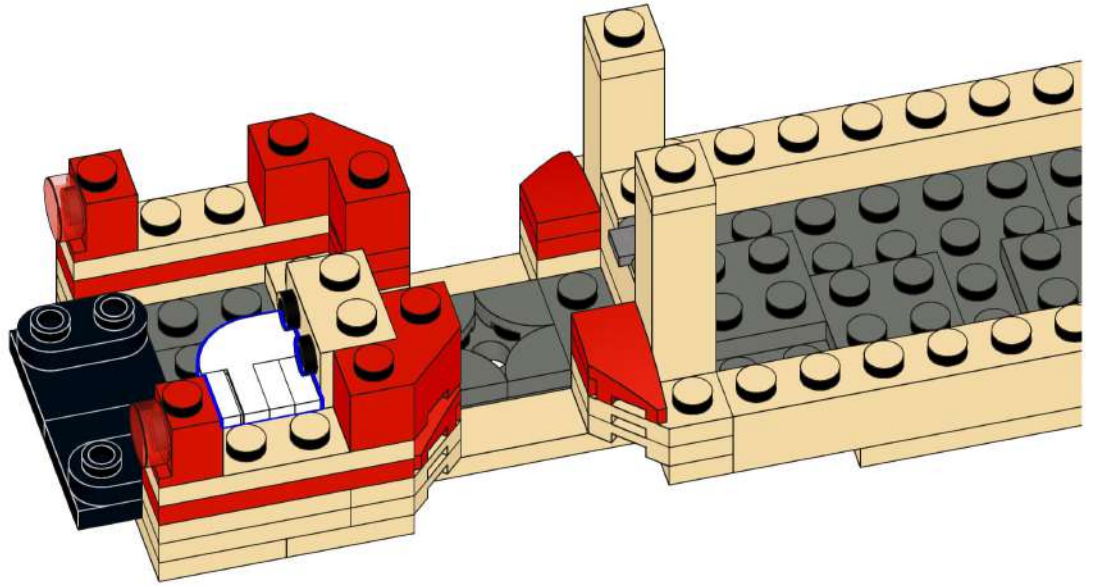
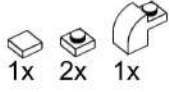

17

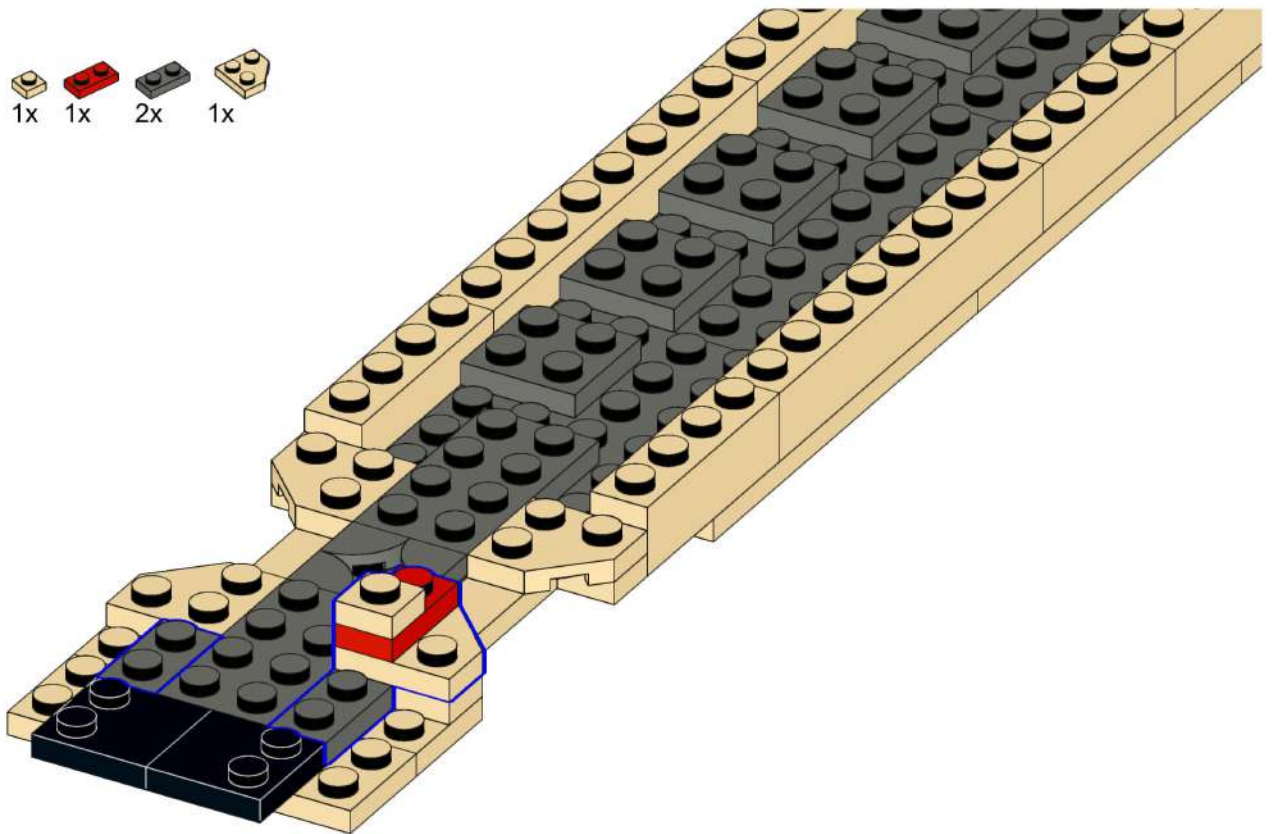
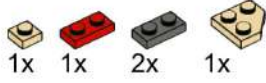

18

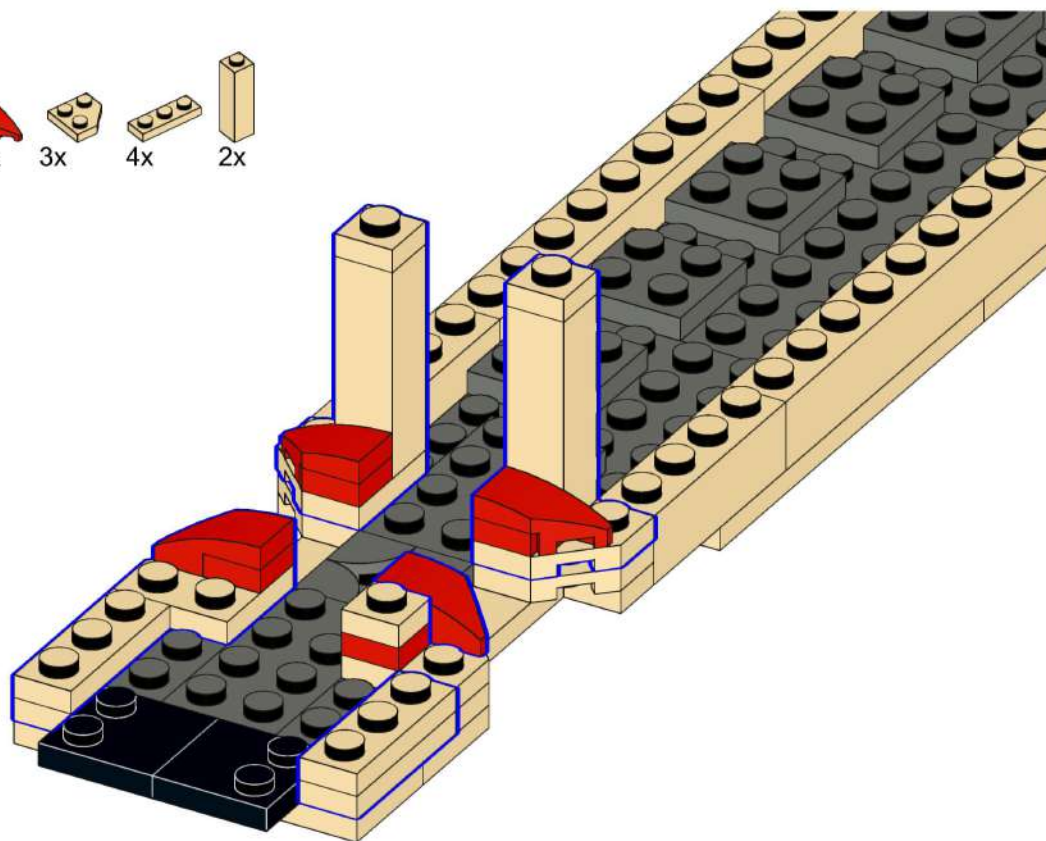
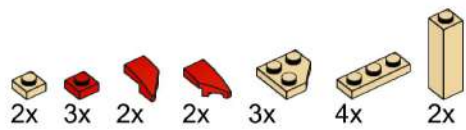

19

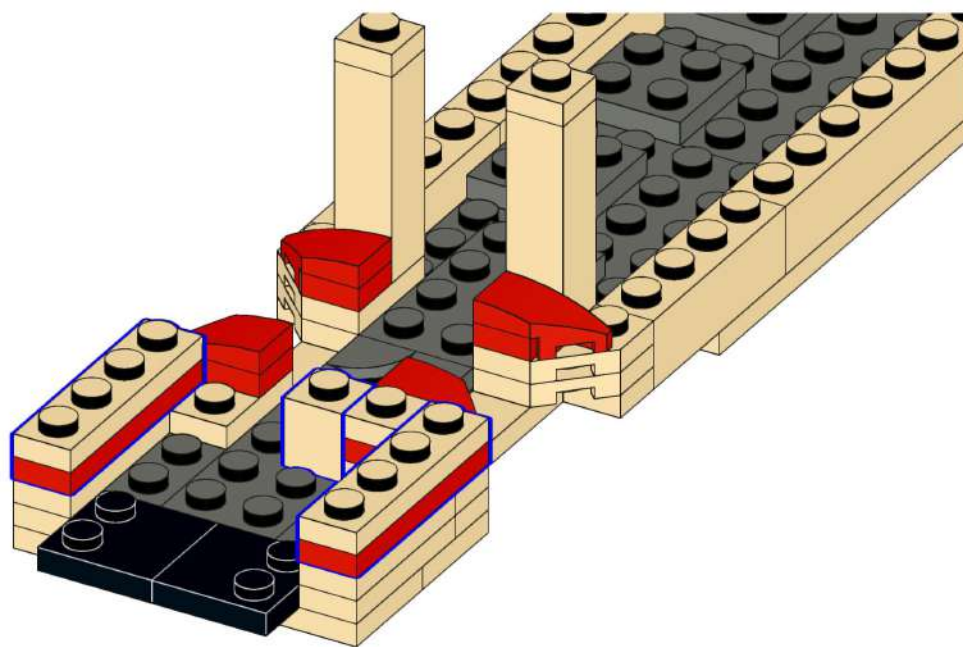
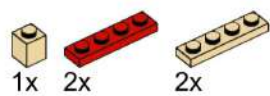

20

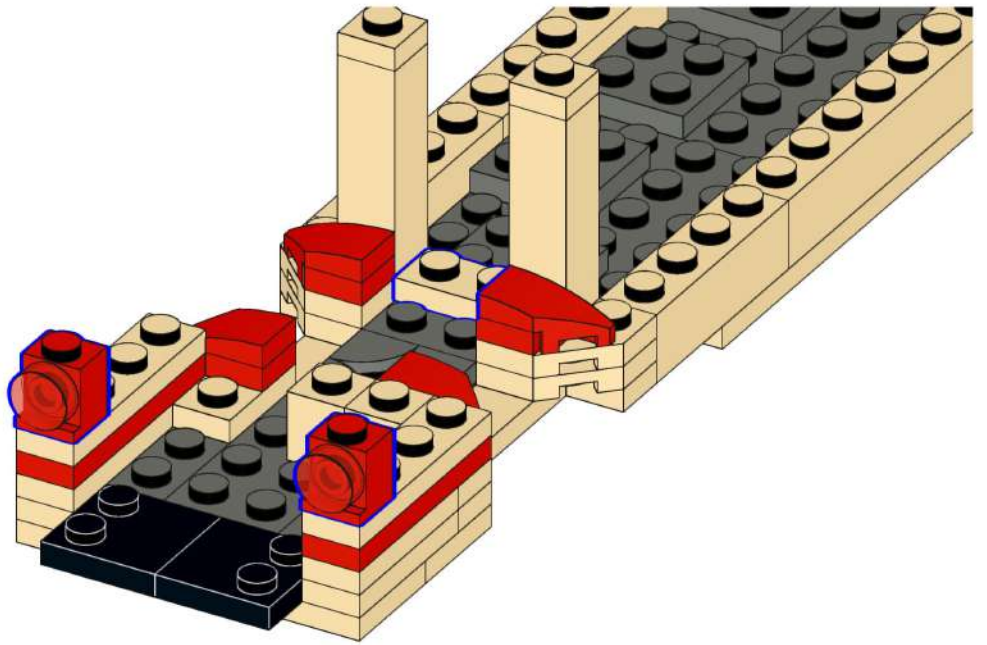

21

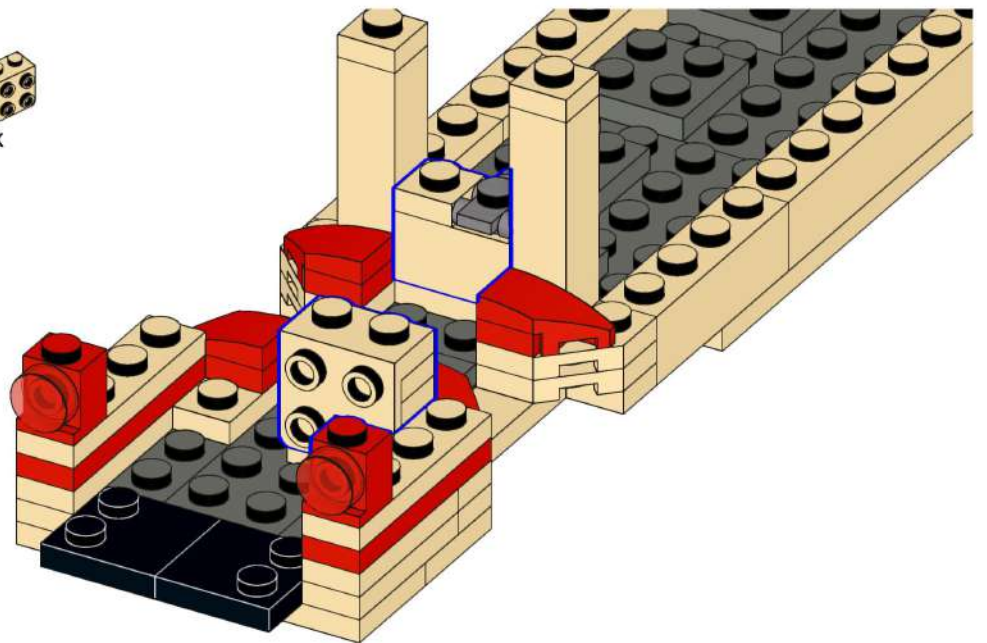
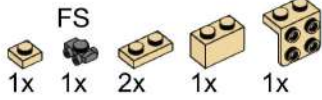

22

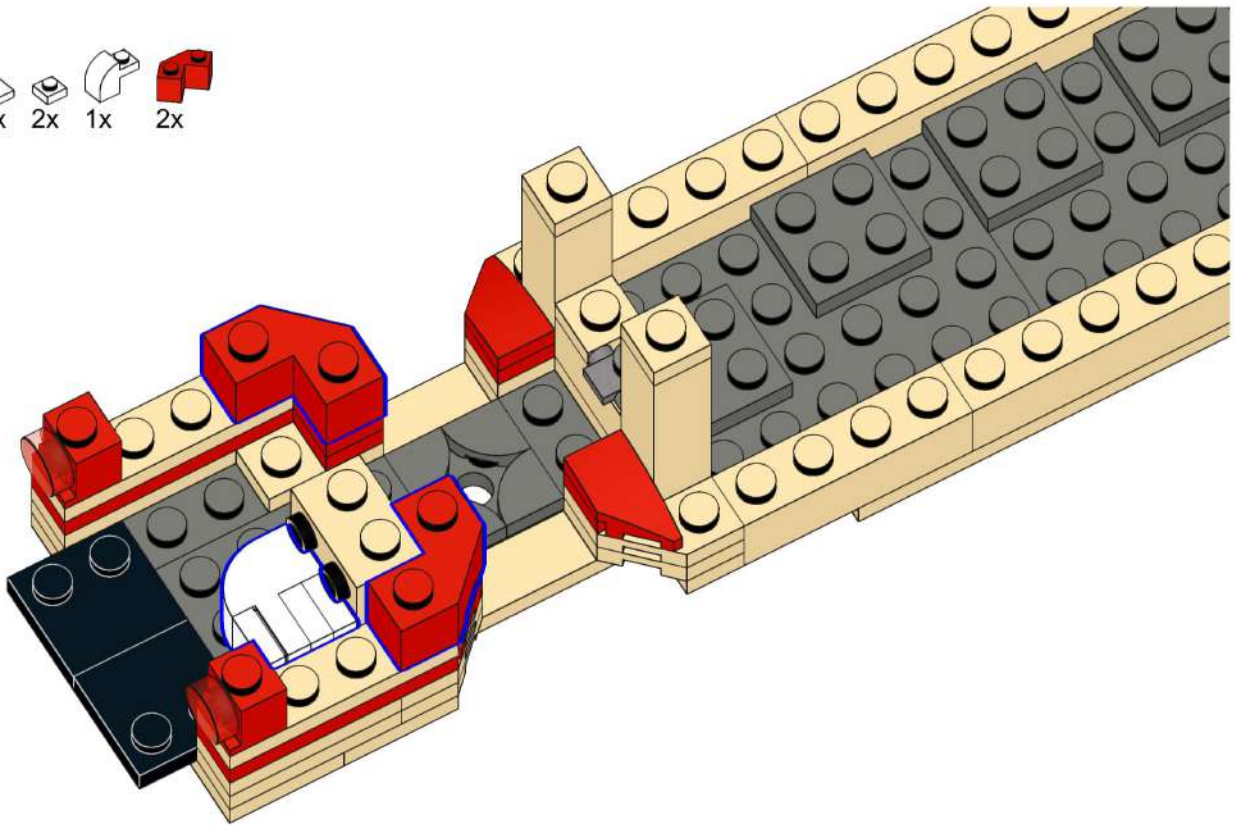
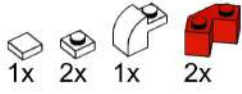

23

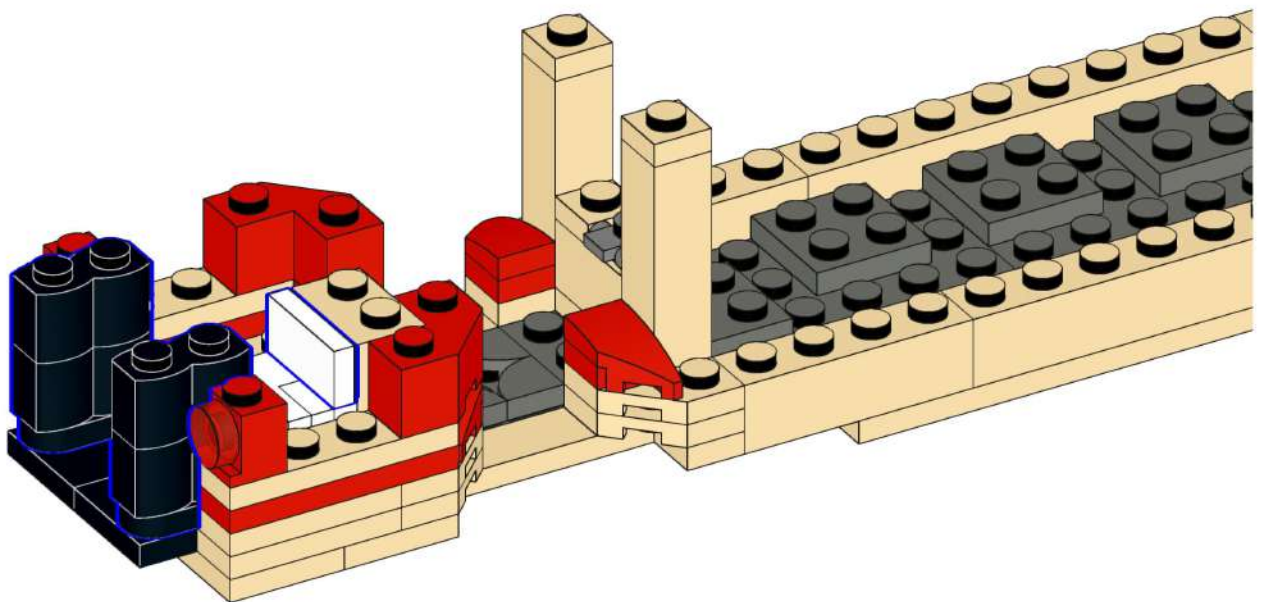

24

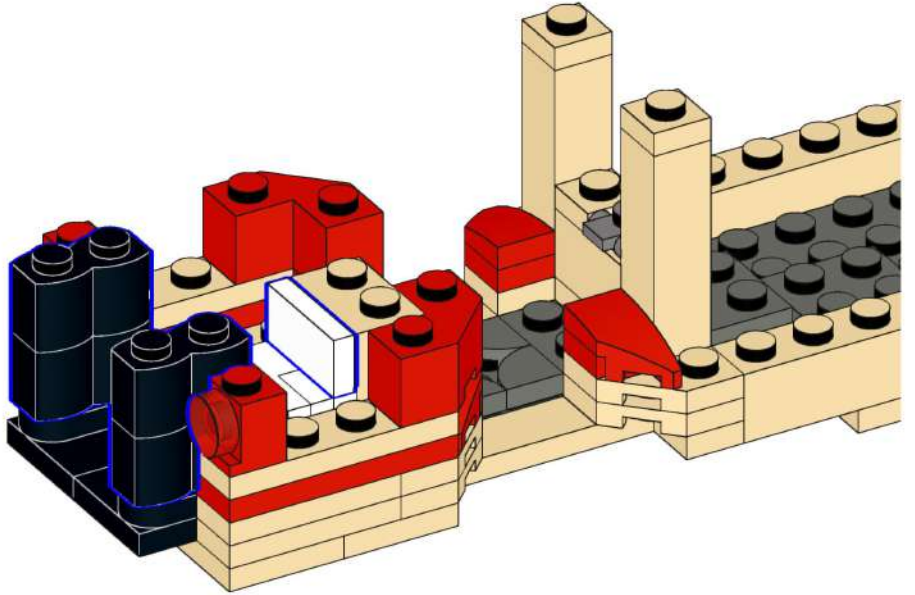
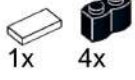

25

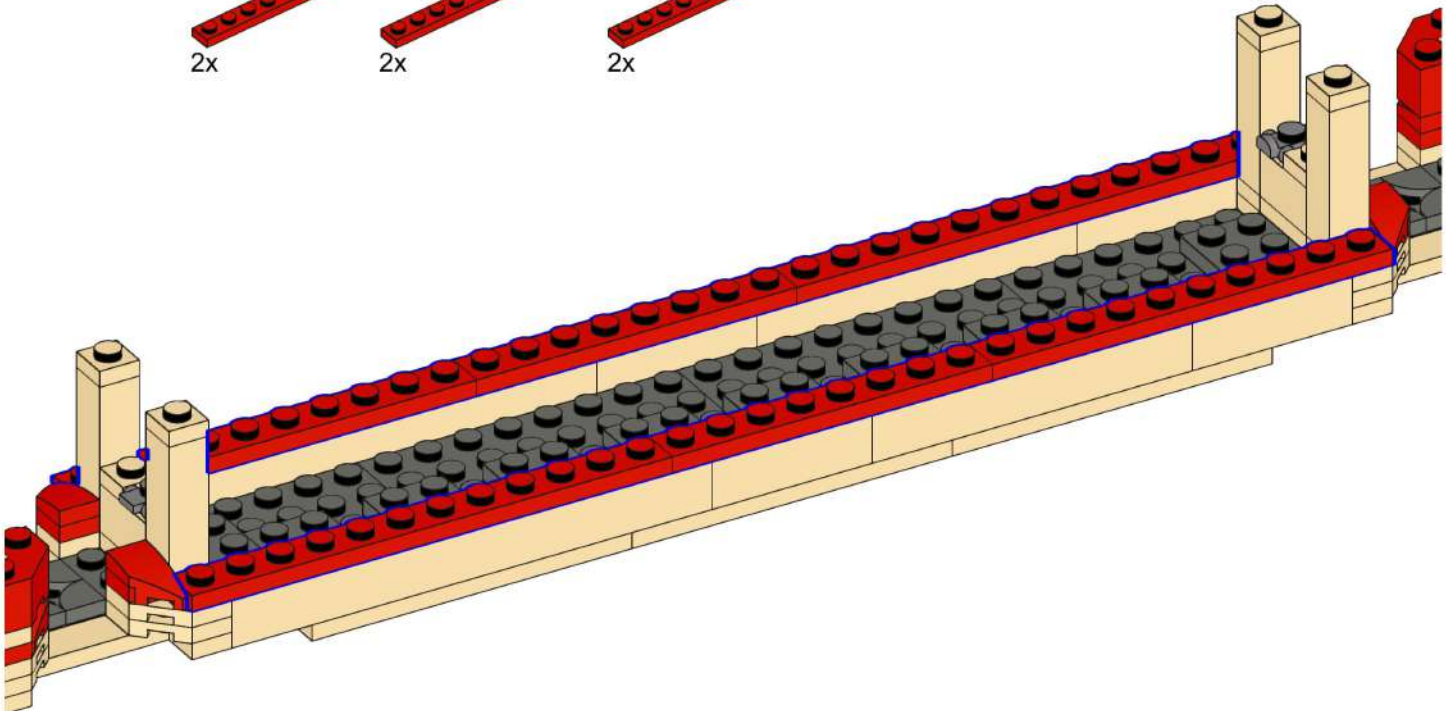

26

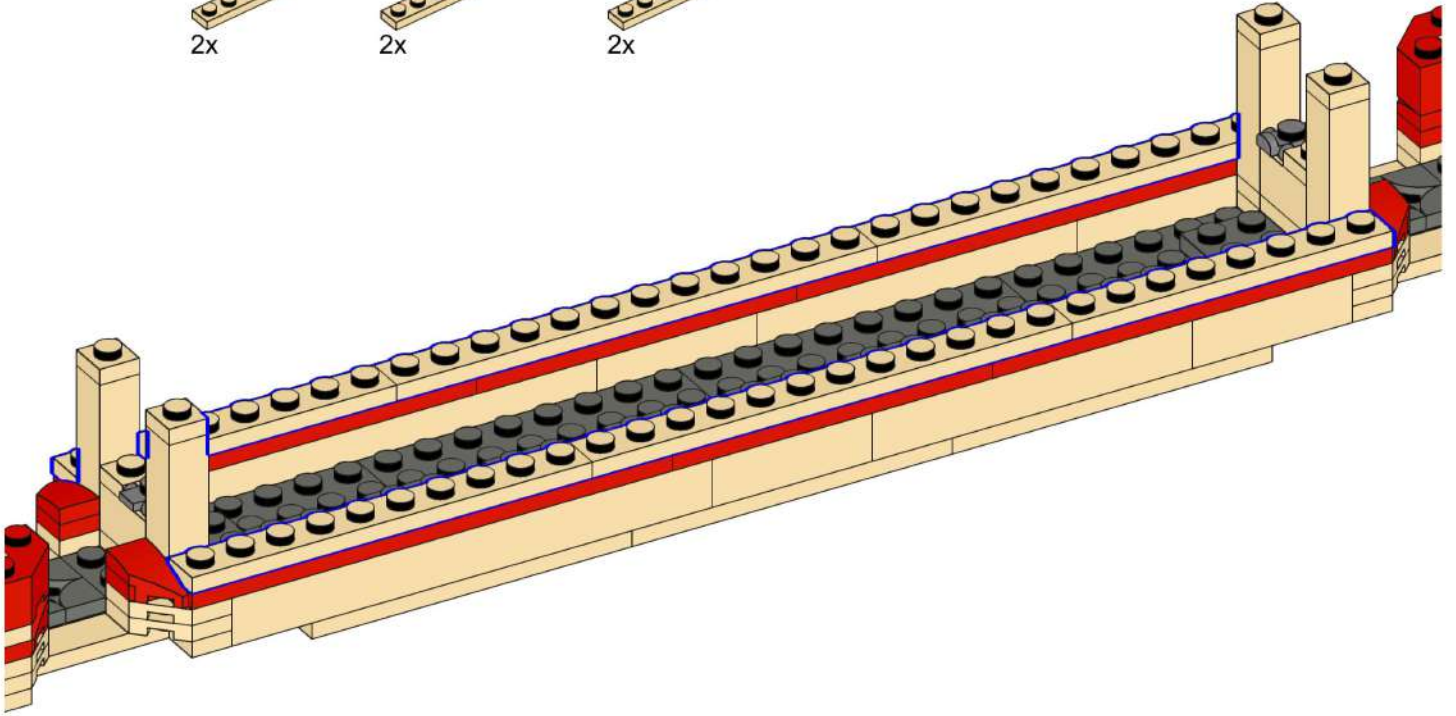

27

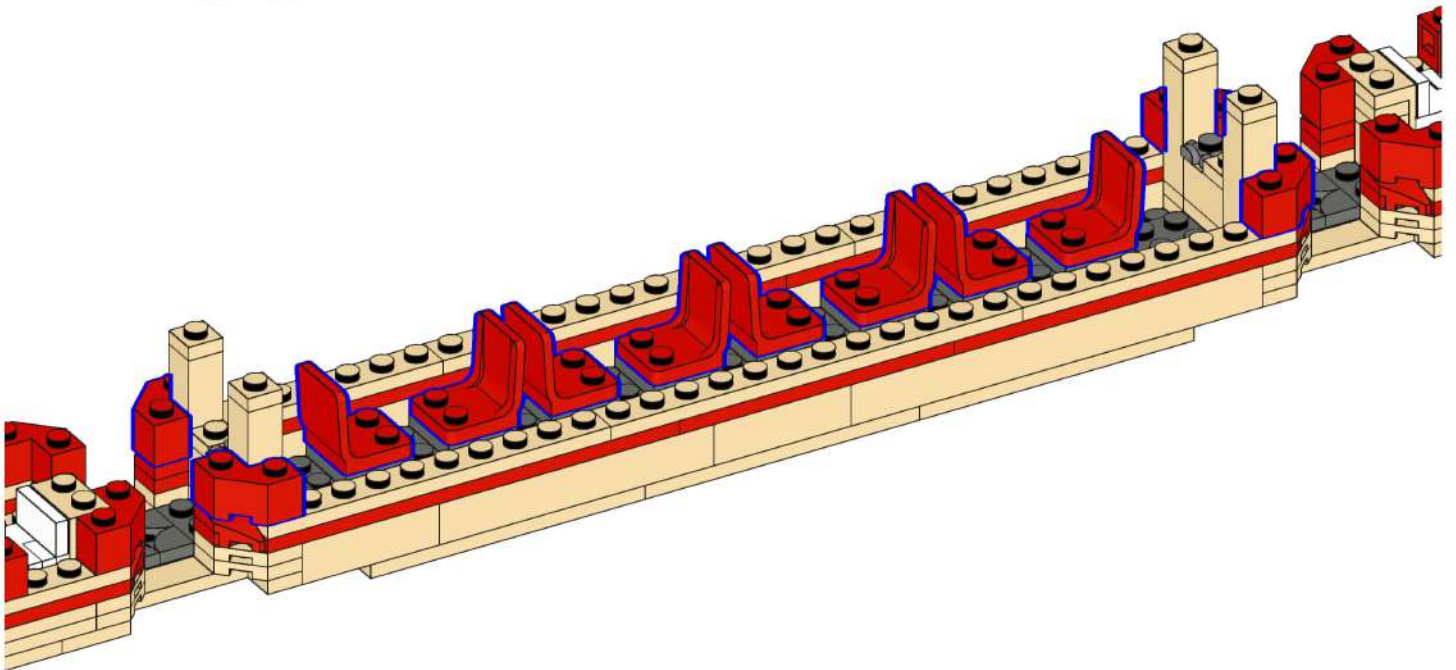
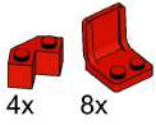

28

2x 2x 2x 4x 2x

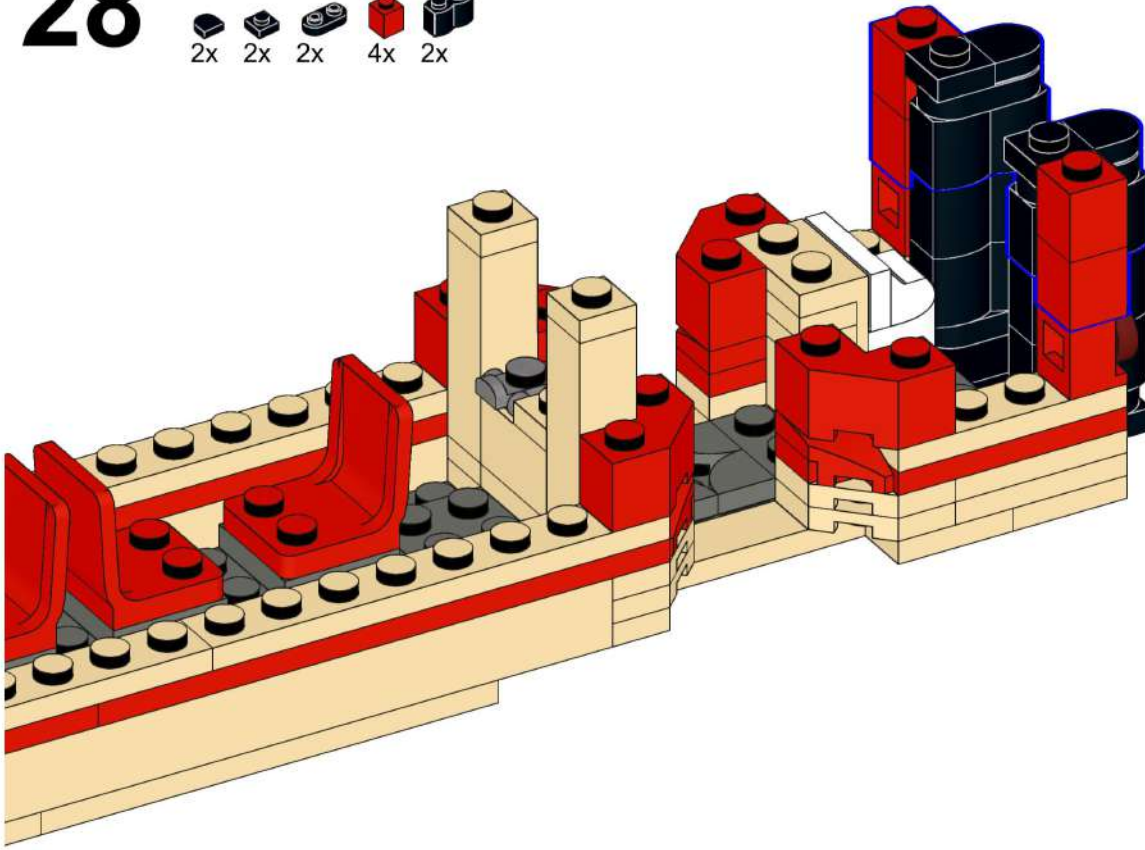

29

2x 1x

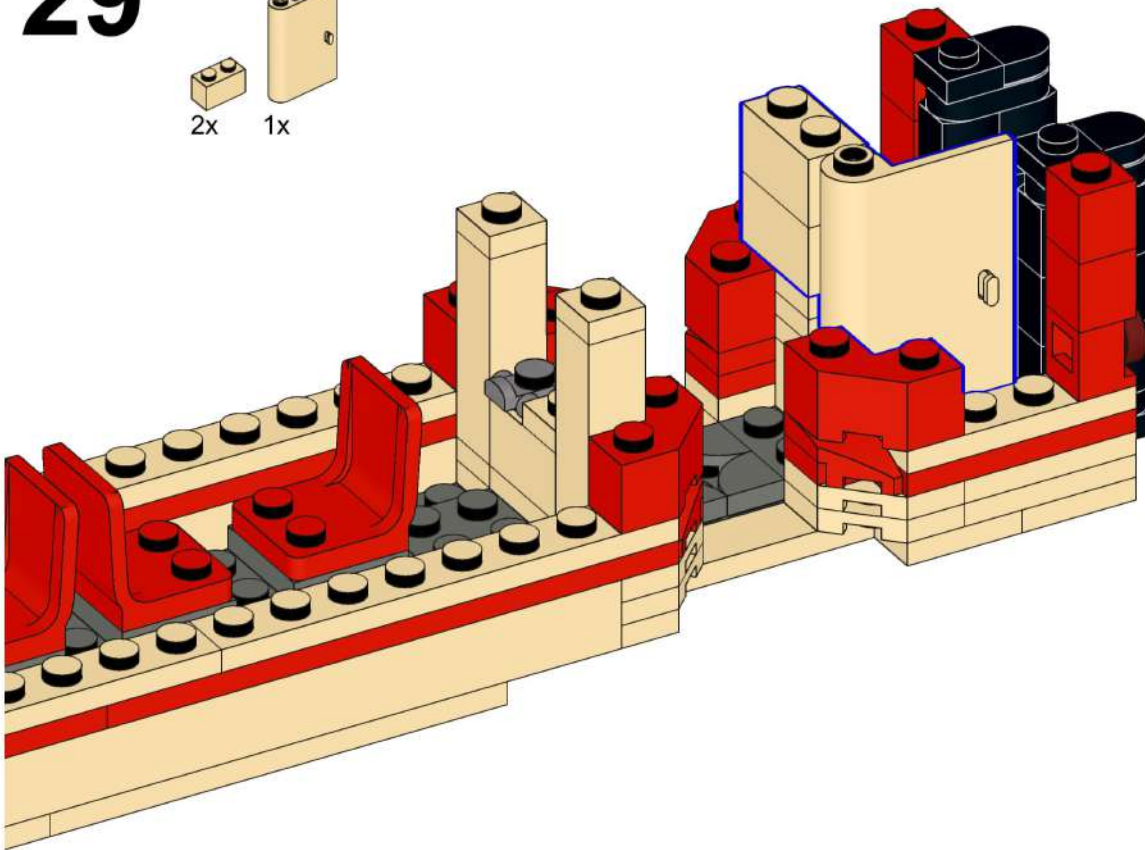

30



4x

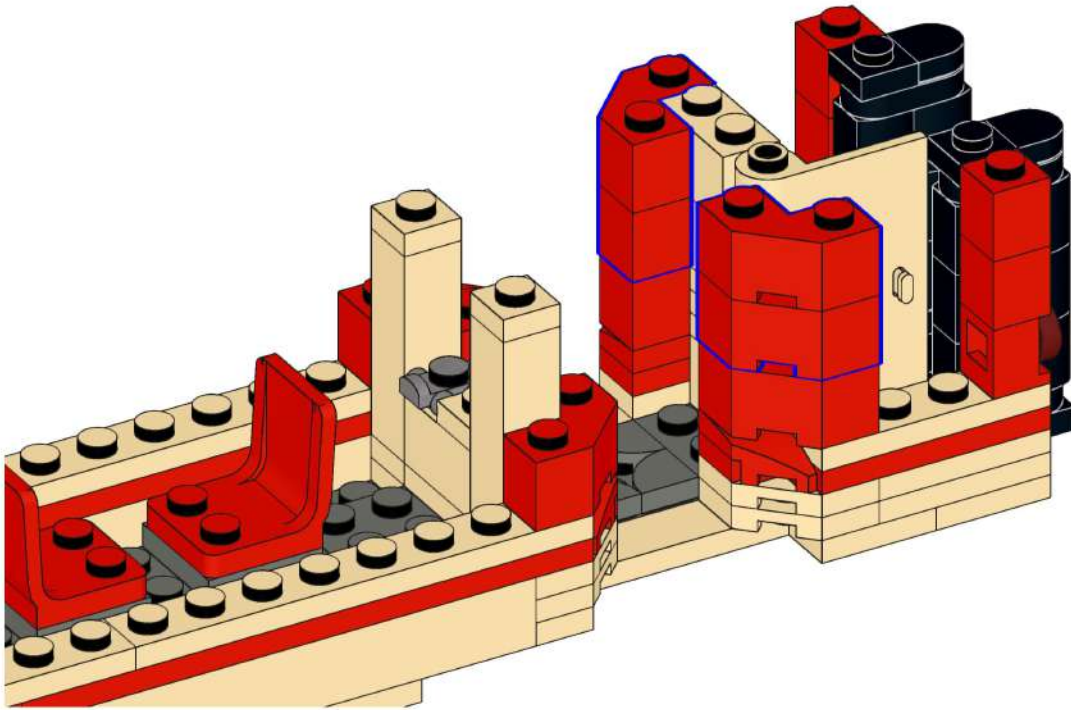

31



1x



1x



1x

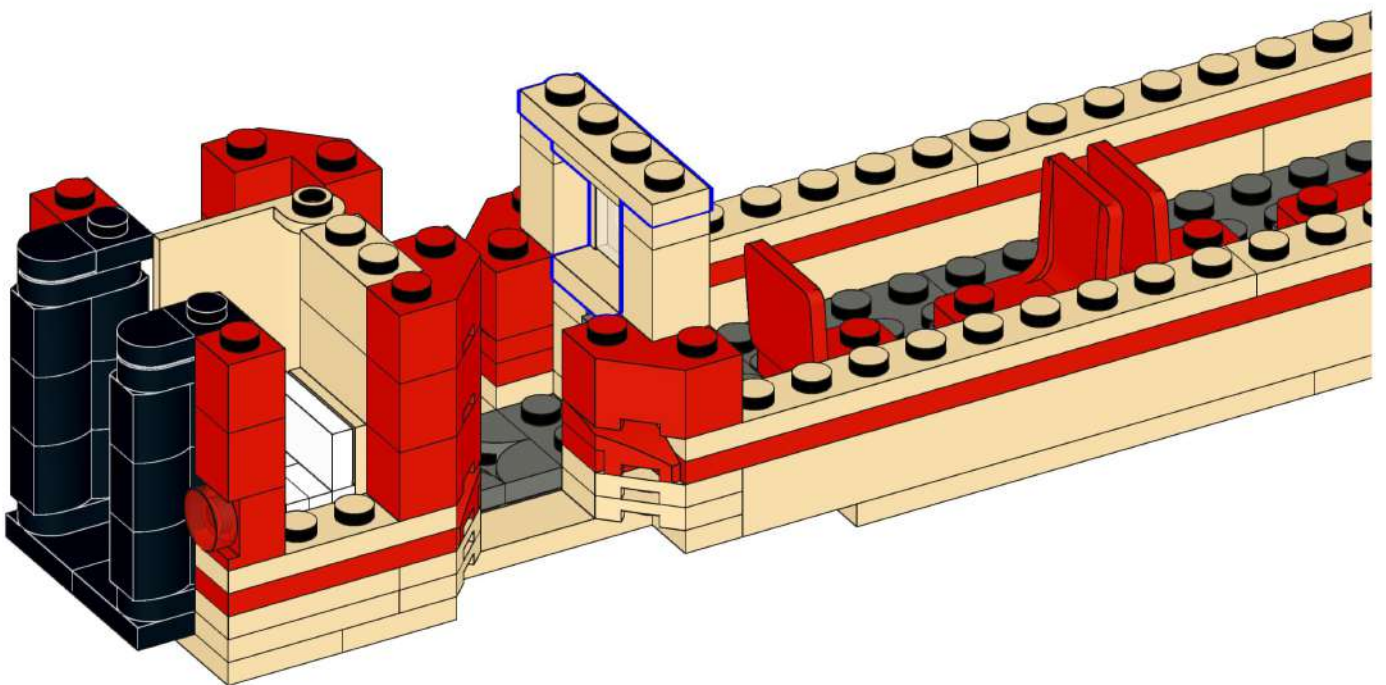

32



4x

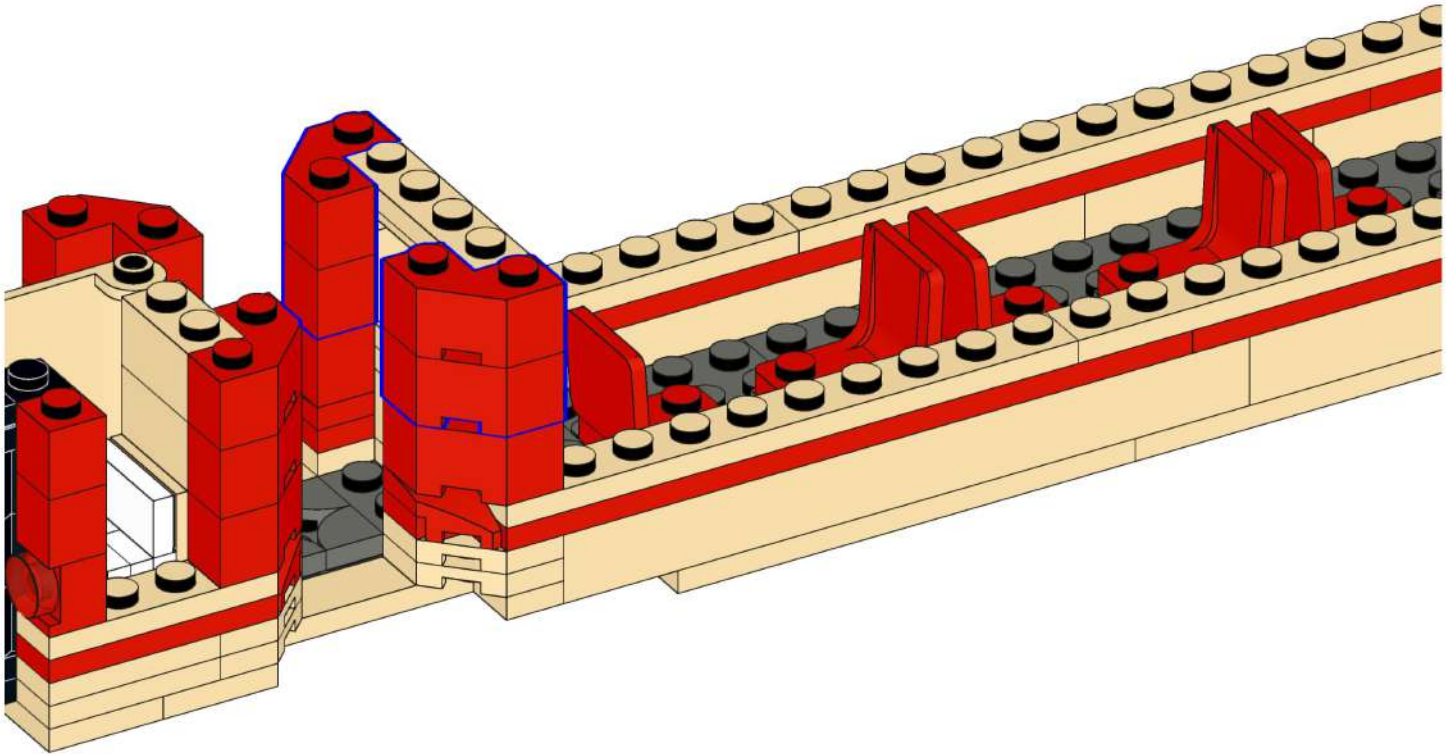

33



1x

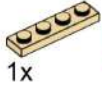

1x



4x



1x

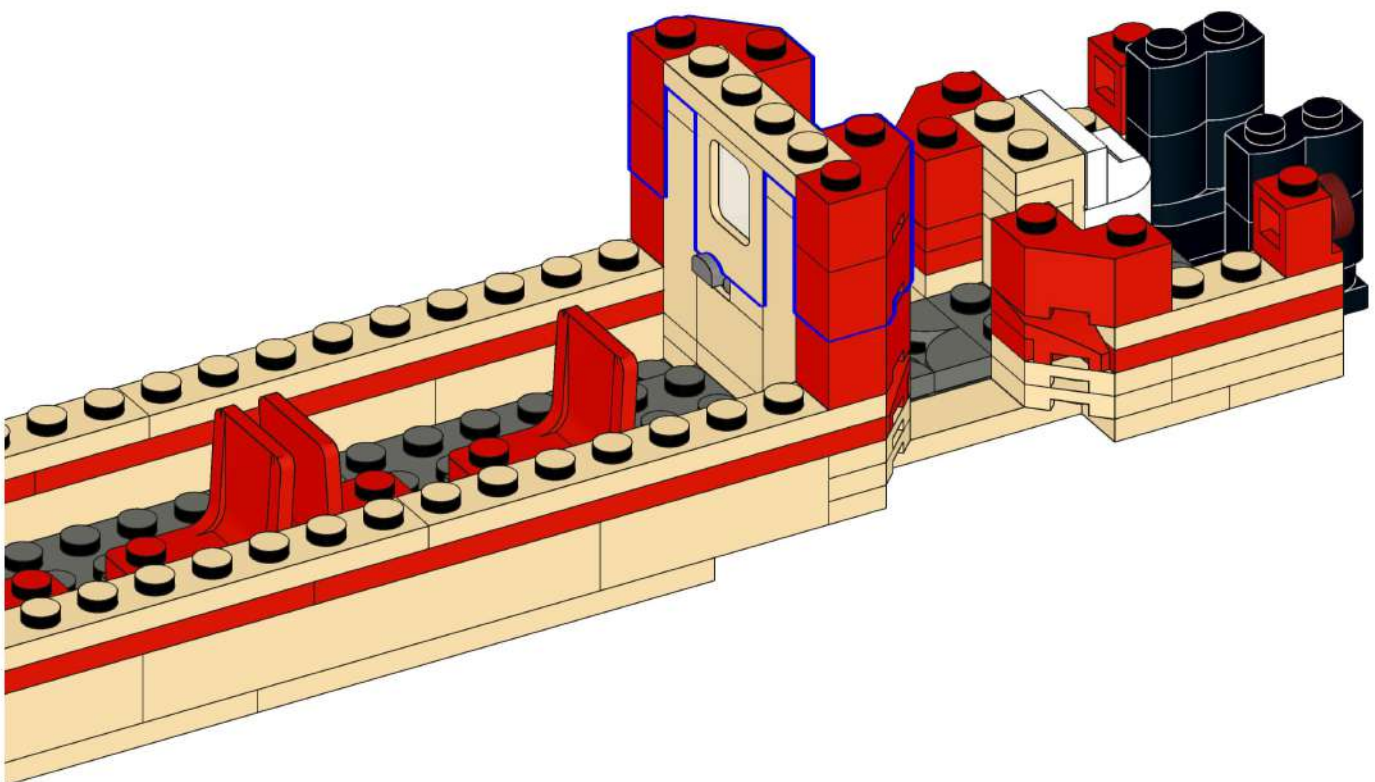

34

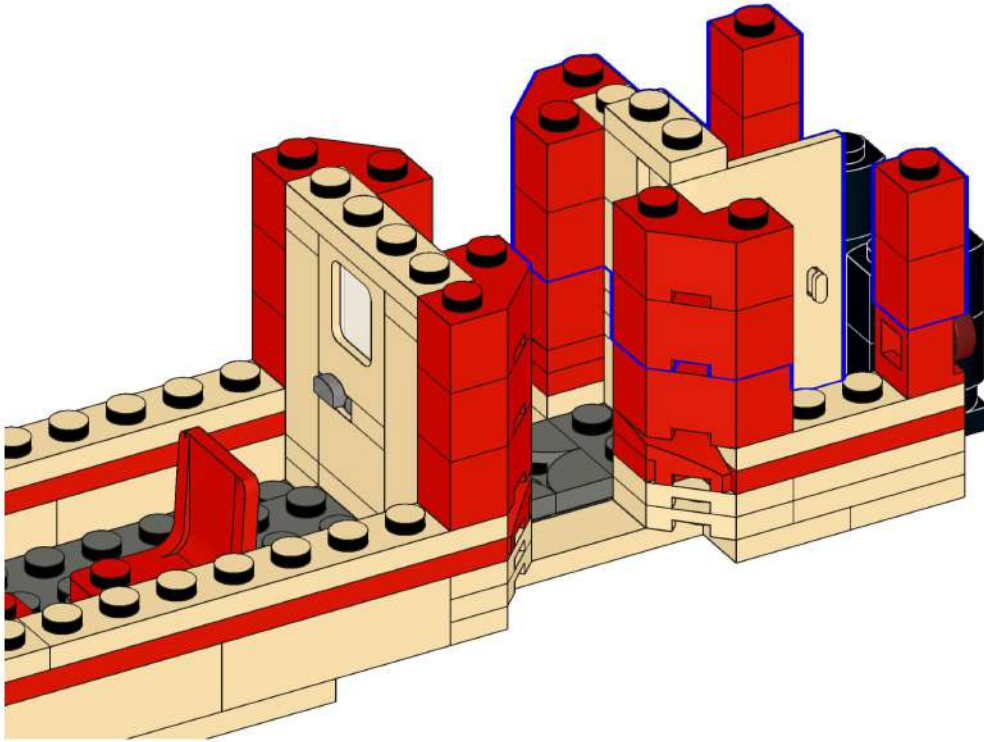
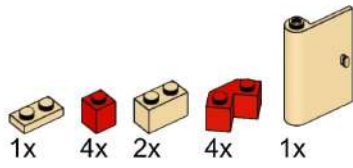

35

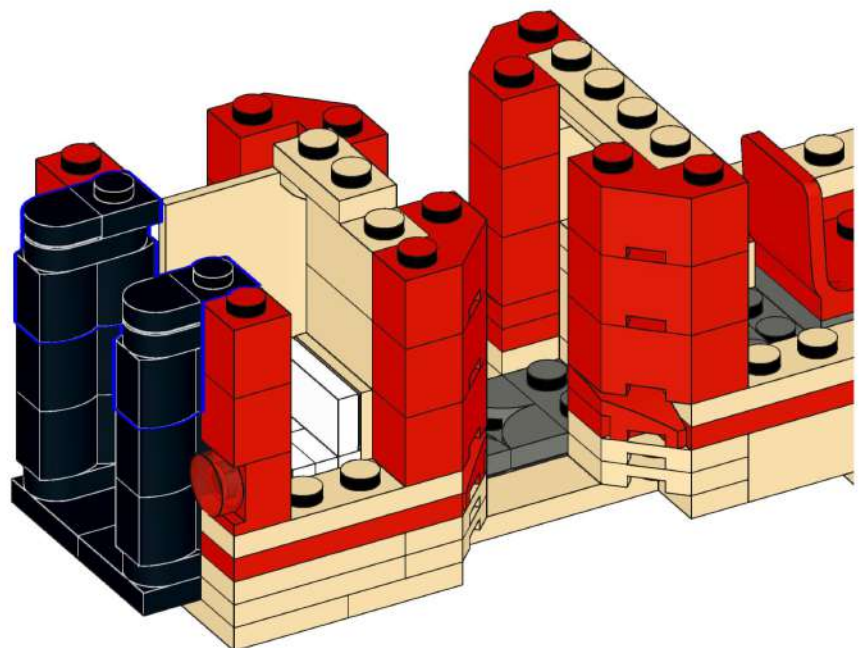

36



- 2x
- 2x
- 14x
- 4x
- 14x

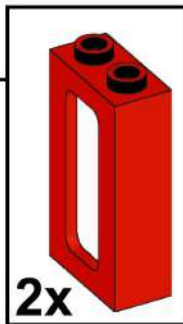
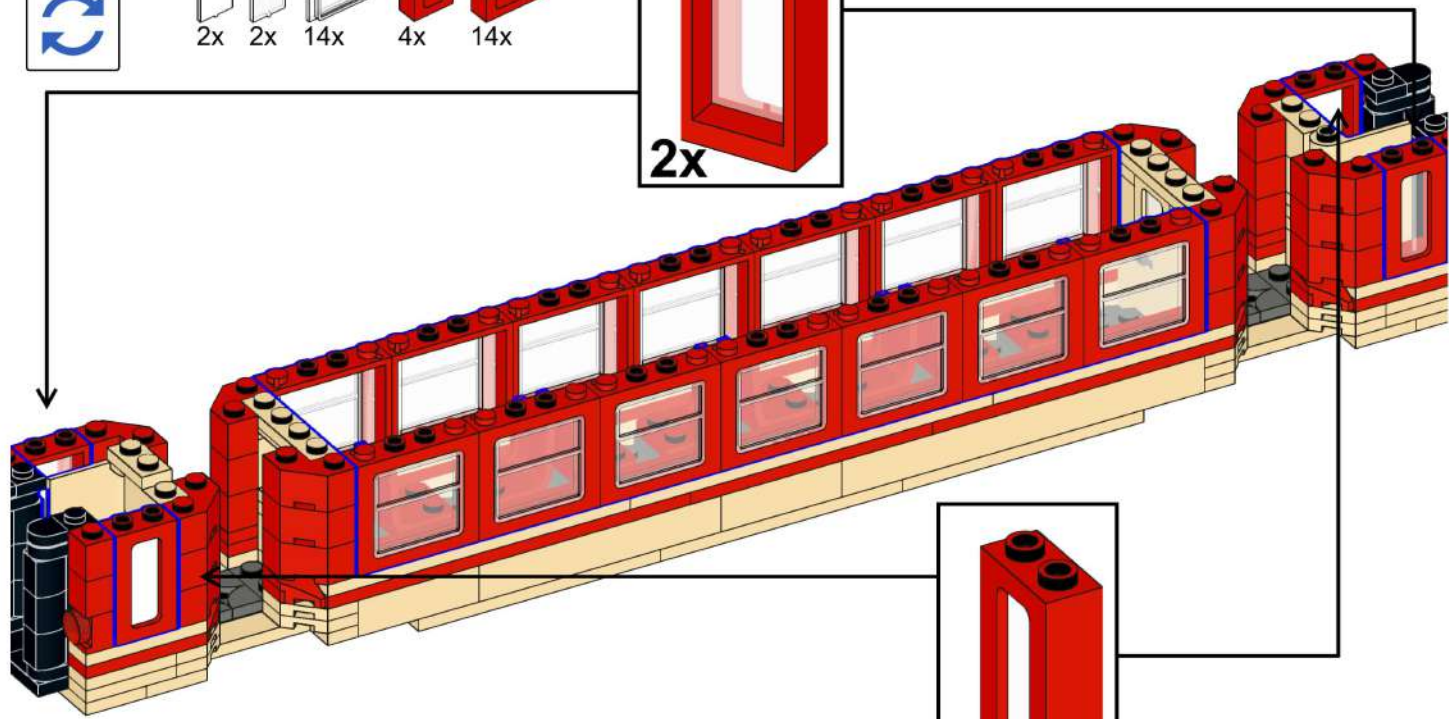
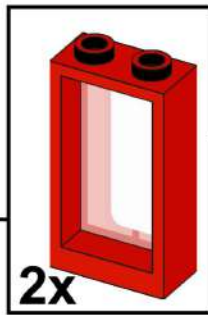

37

- 2x
- 1x
- 1x
- 1x

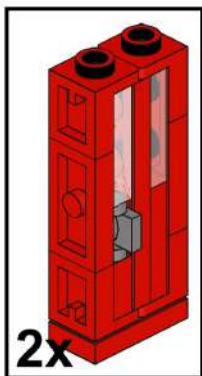
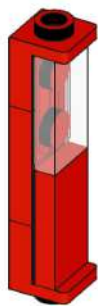

38



- 1x
- 1x
- 2x
- 1x
- 1x
- 1x

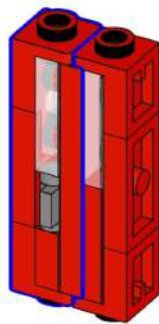

39

- 1x

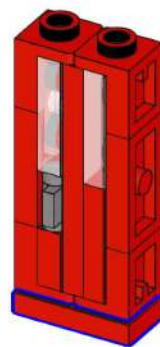

40



4x

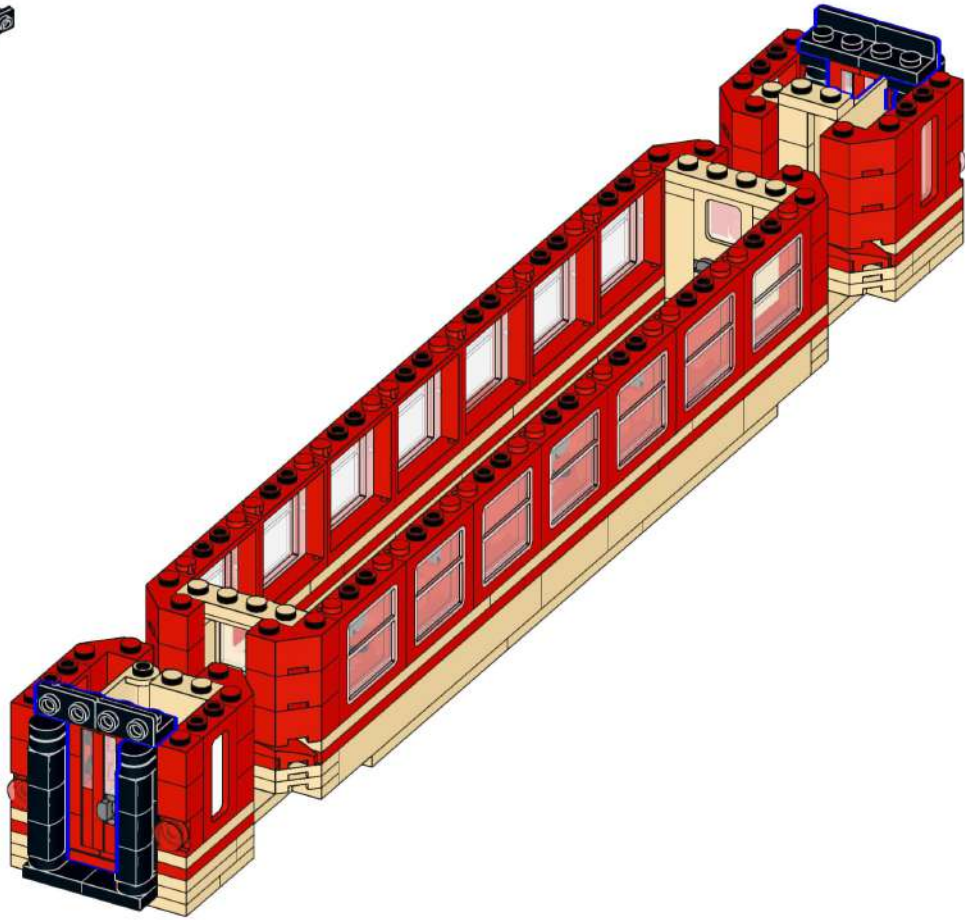

41



8x

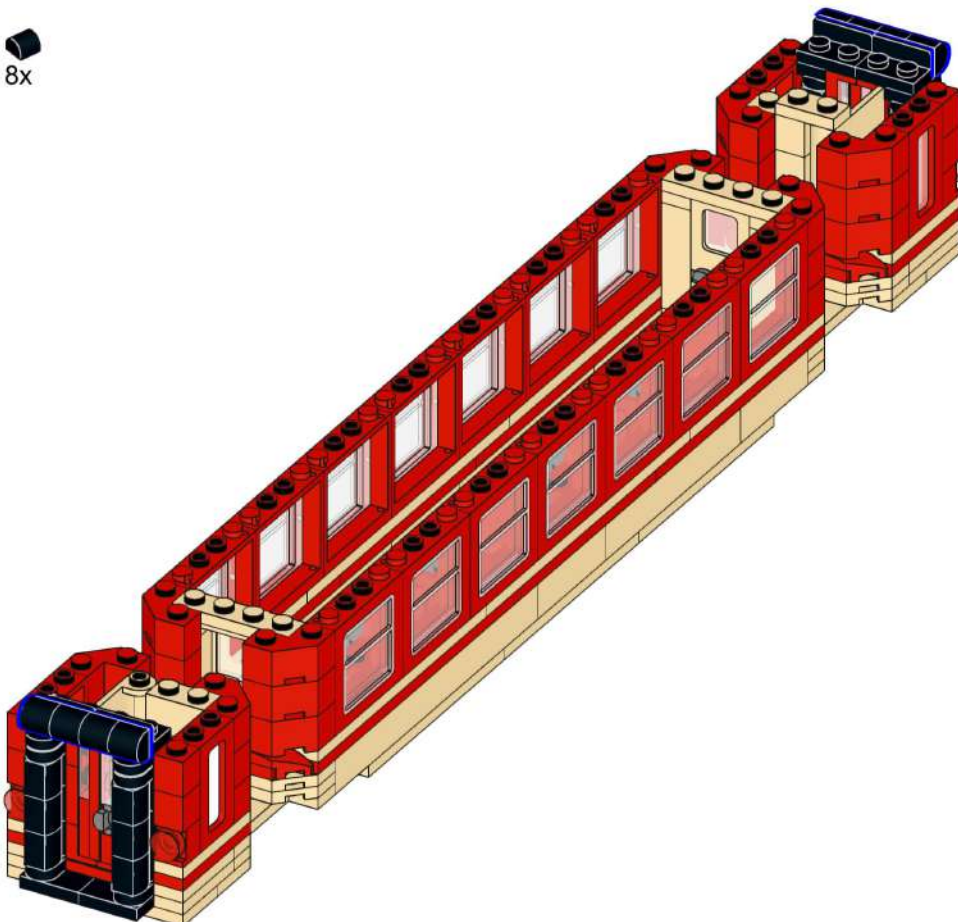

42

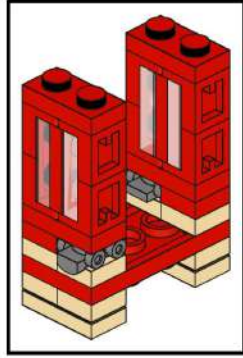
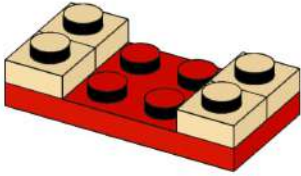
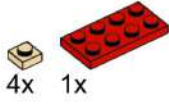

43

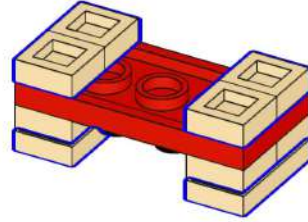

44

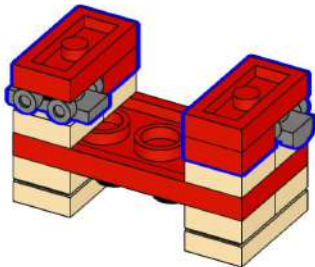
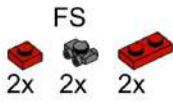

45

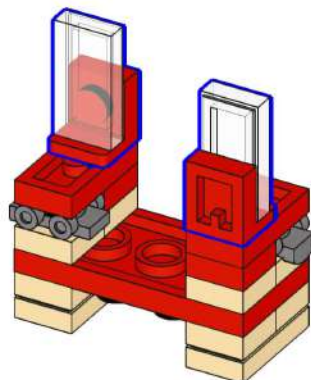

46

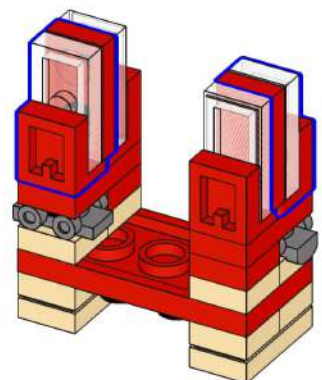
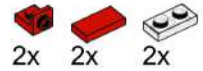

47

4x 

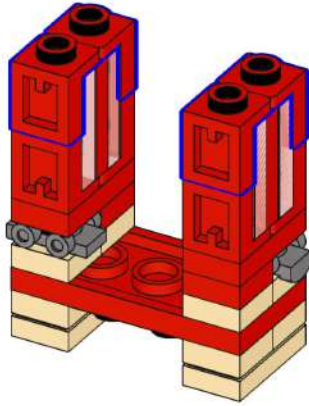



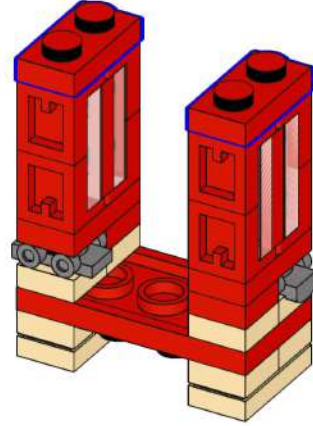

48

2x 



49



3x  1x  2x  2x 

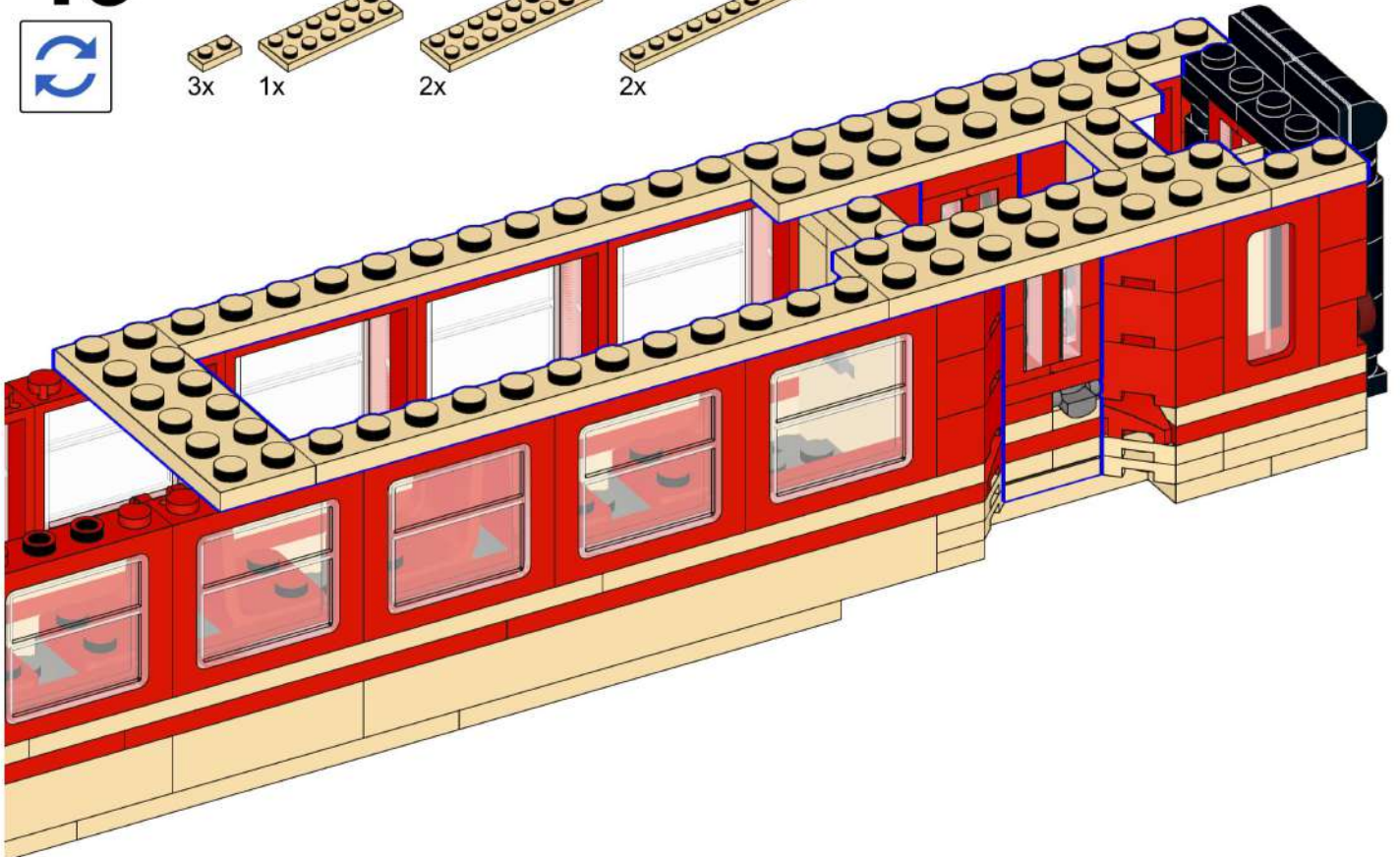

50

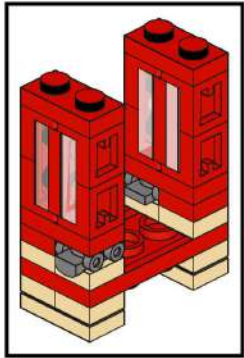
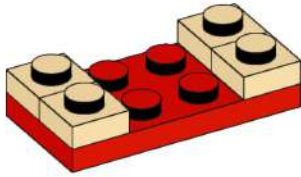
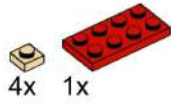

51

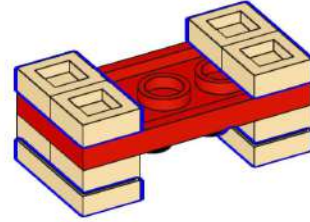
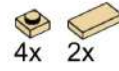

52

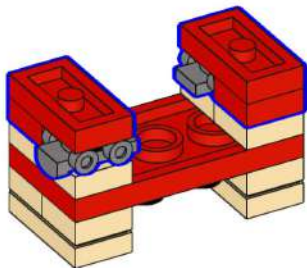
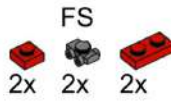

53

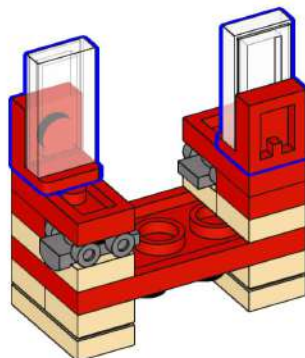

54

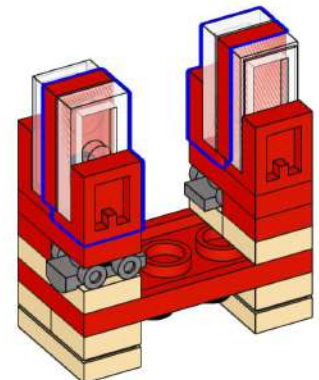
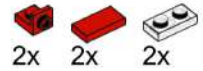

55



4x

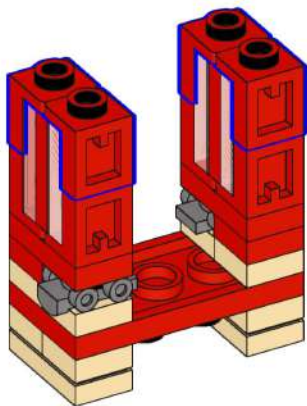

56



2x

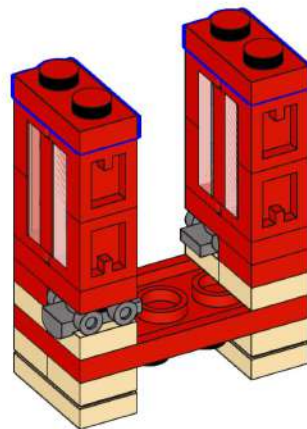

57



2x

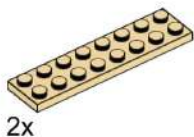

2x



2x

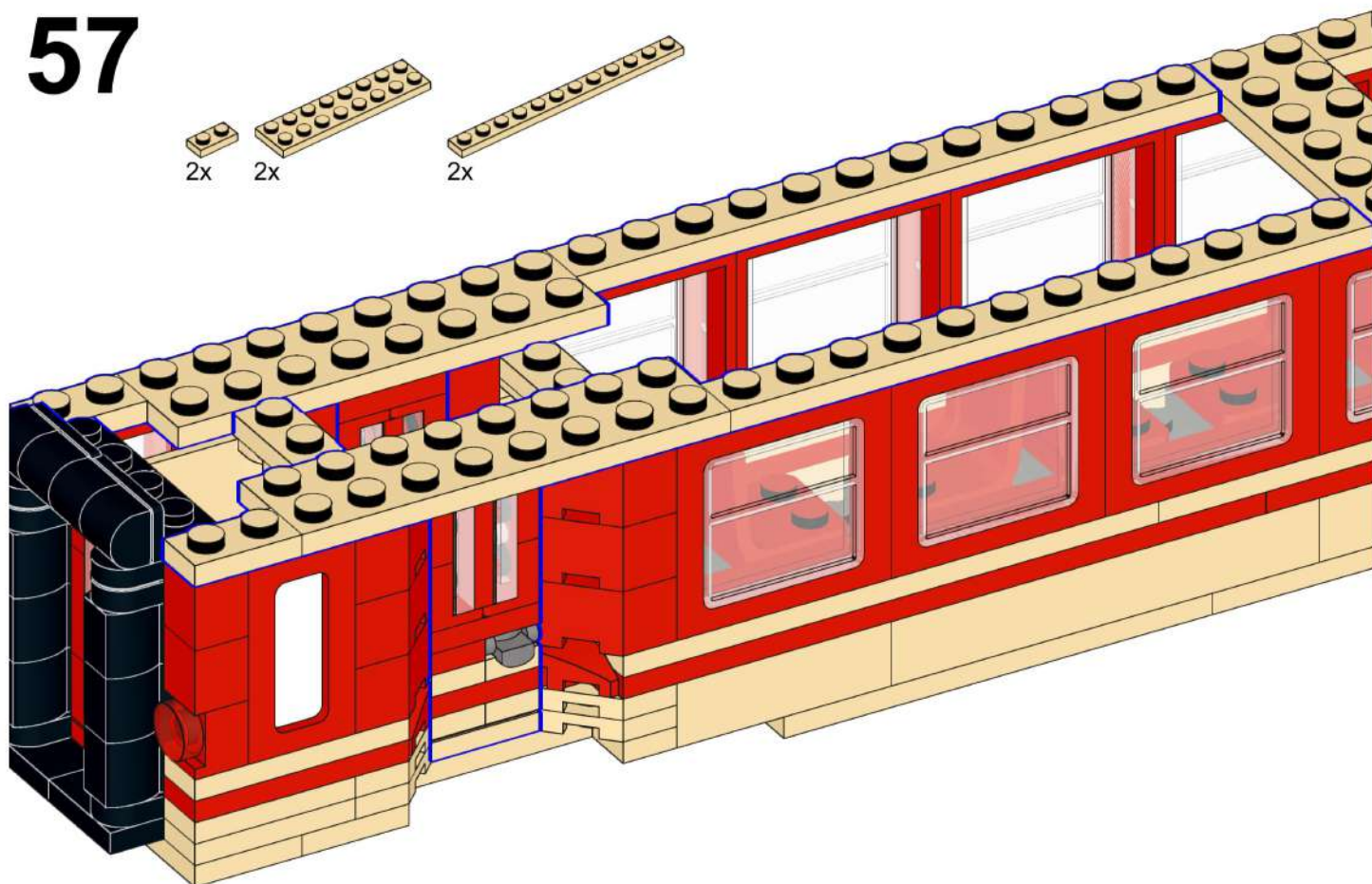

58

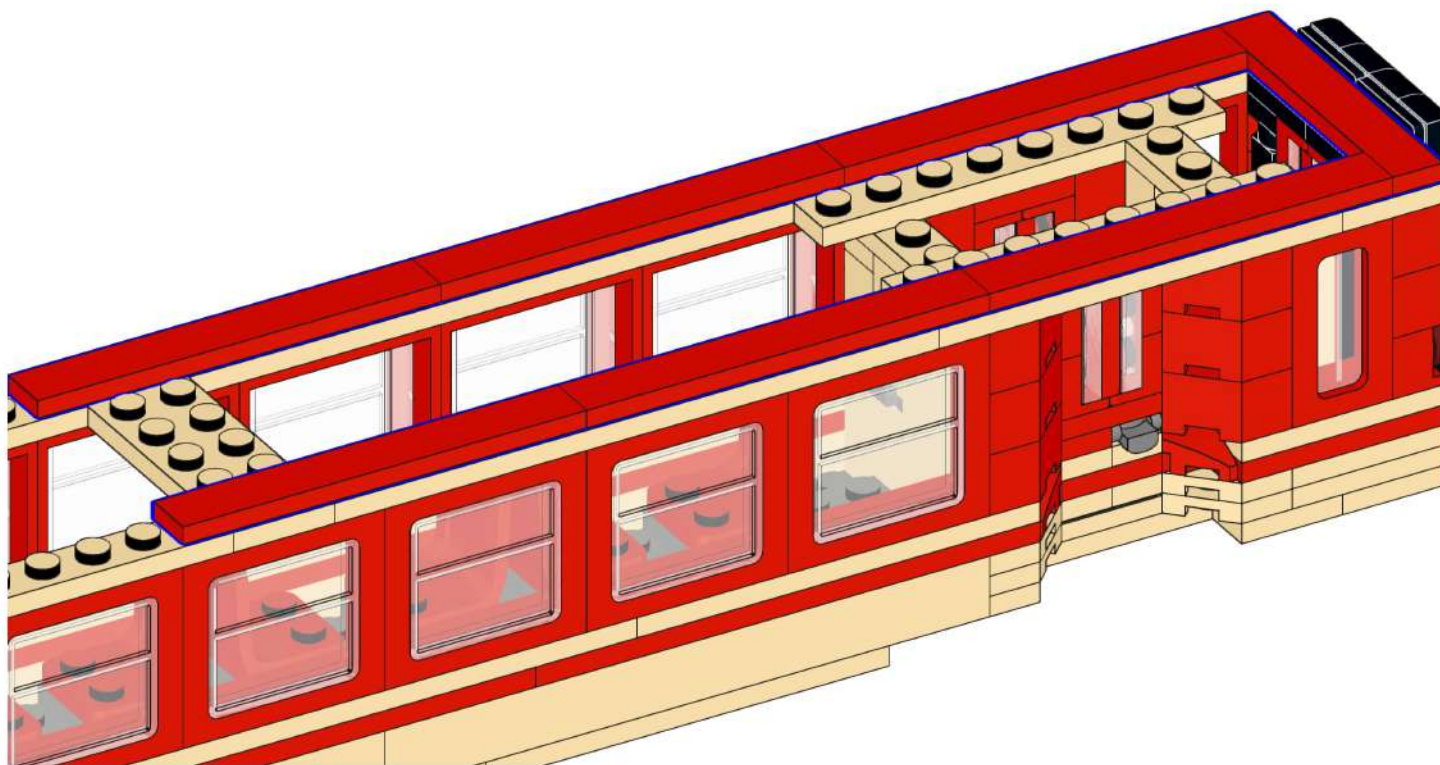
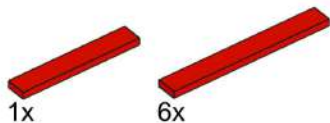

59

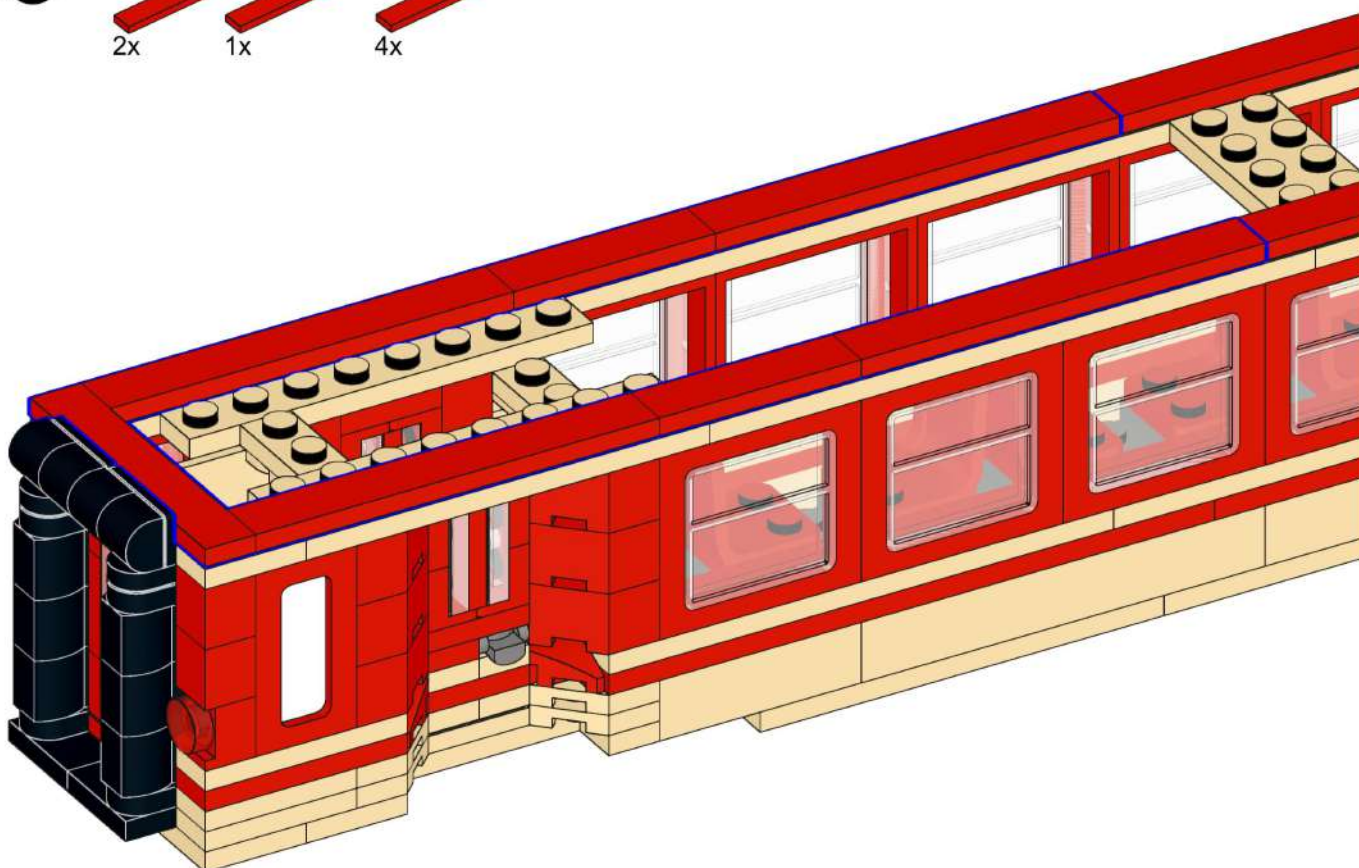
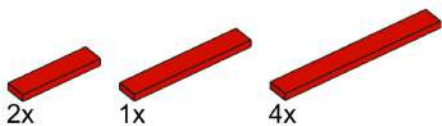

60

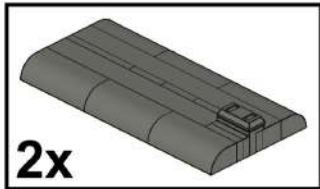
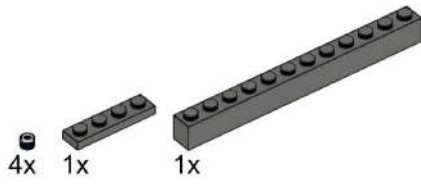

61

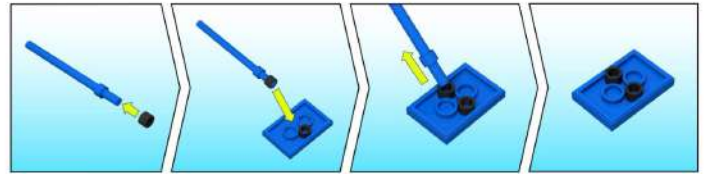
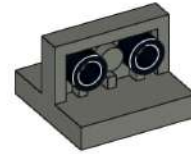
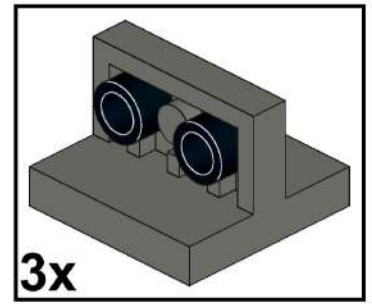
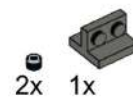

62

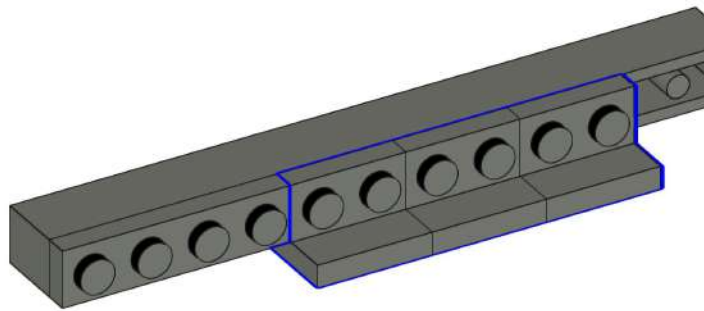

63

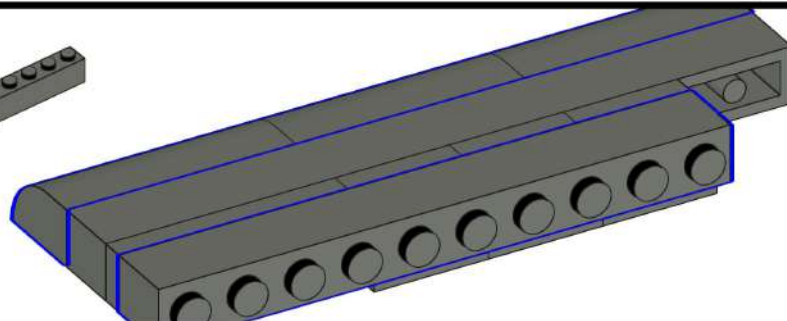
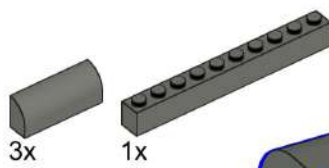

64

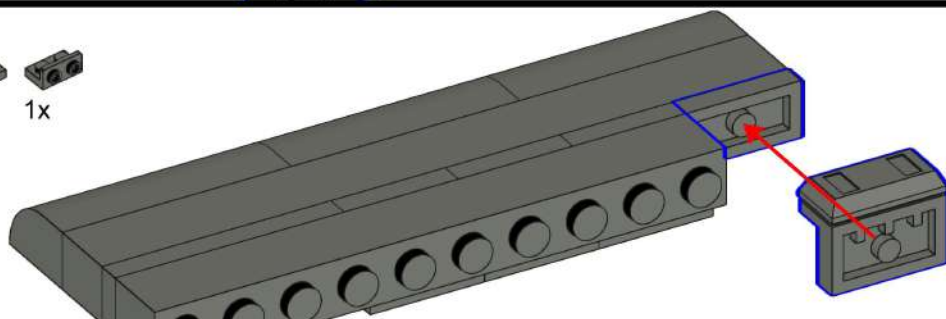

65

2x 2x

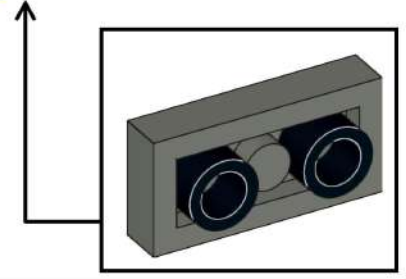

66

3x

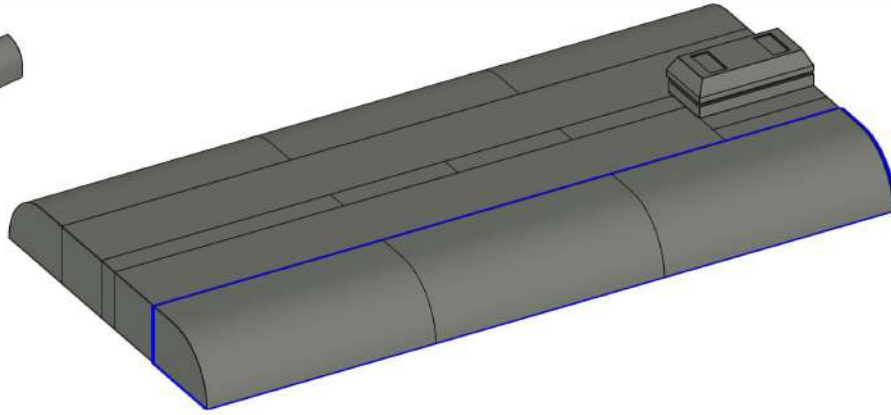

67



1x

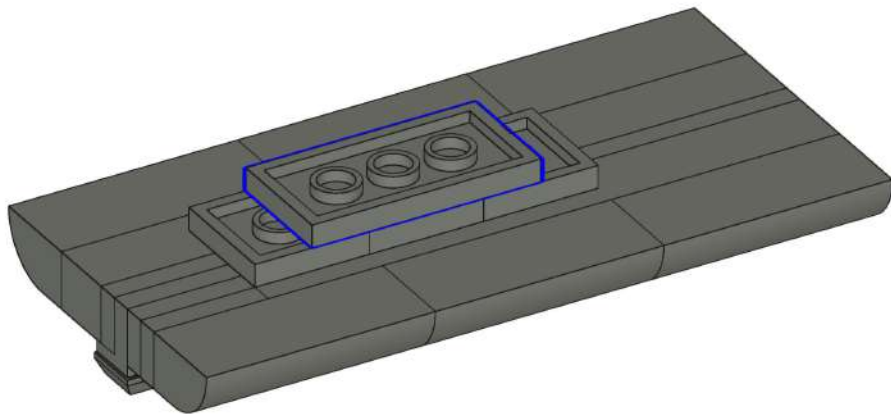

68

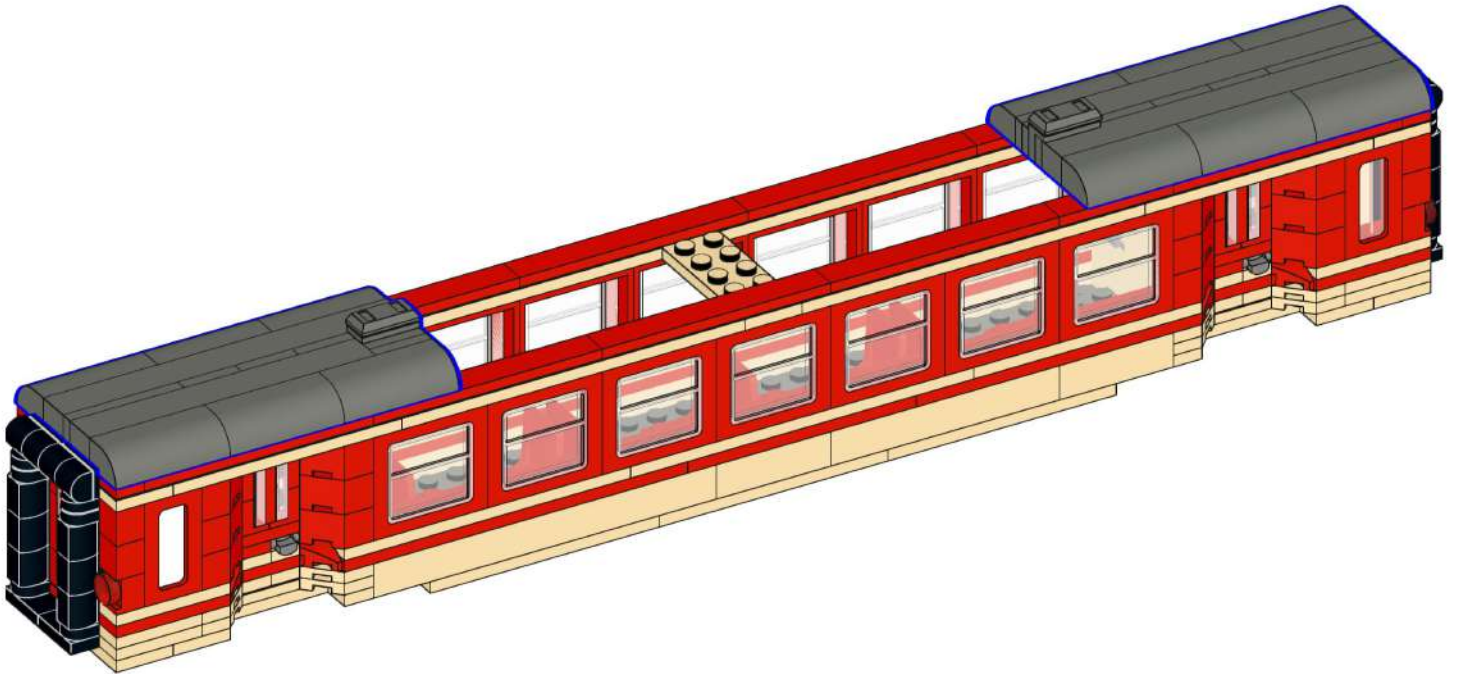

69



2x

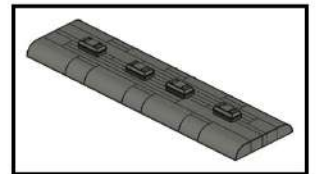
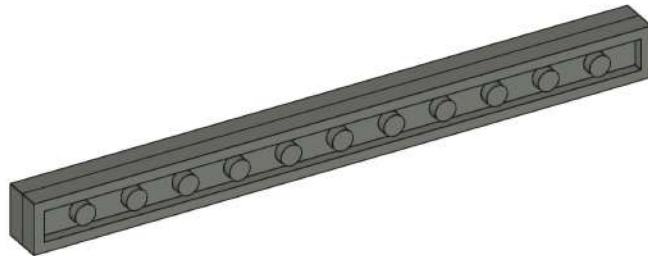

70

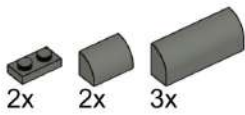

2x

2x

3x

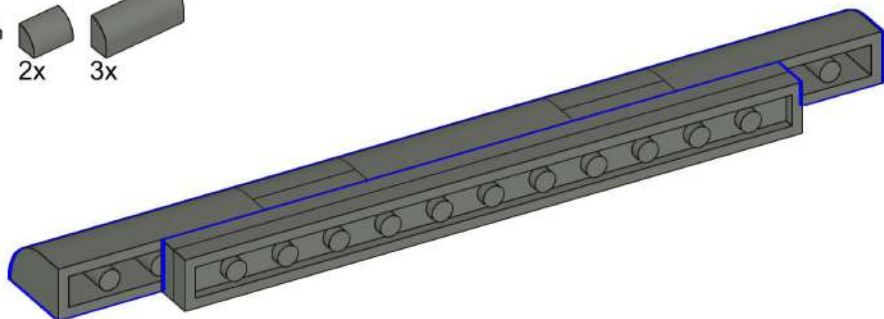

71

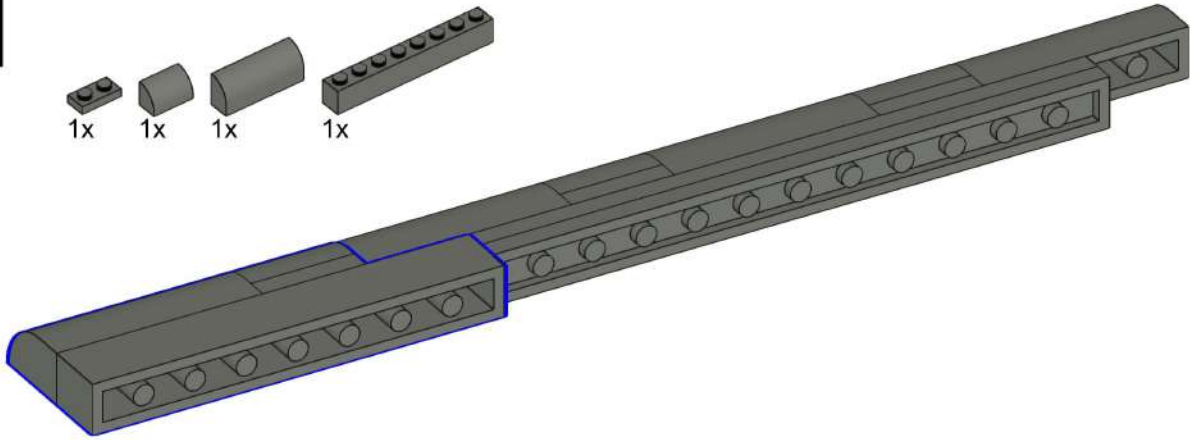
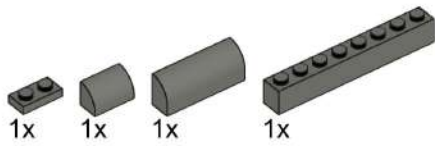

72

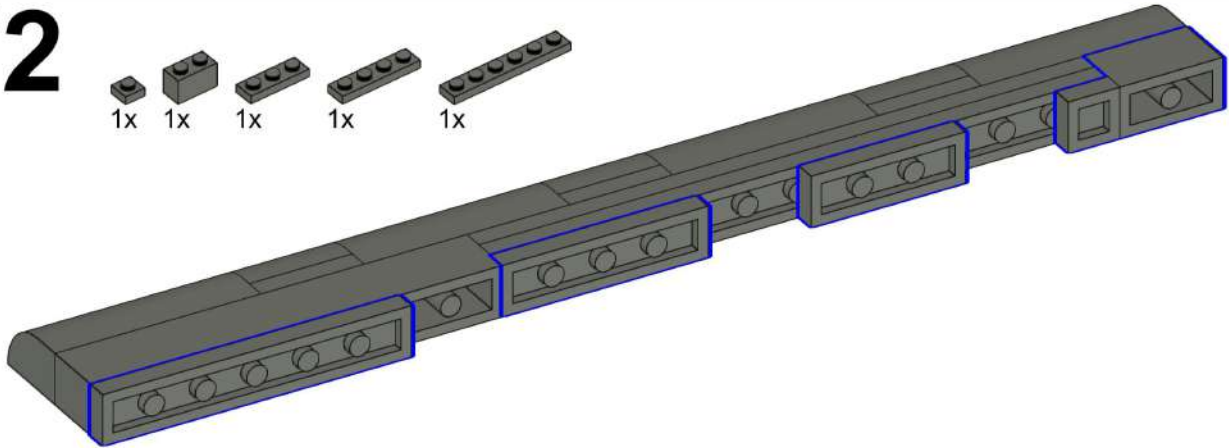
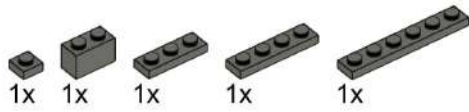

73

6x

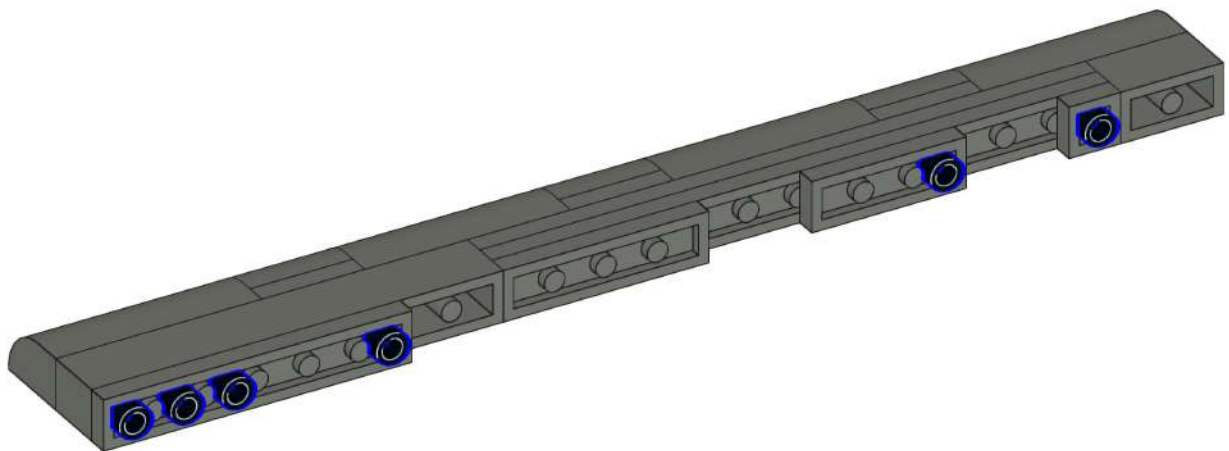

74

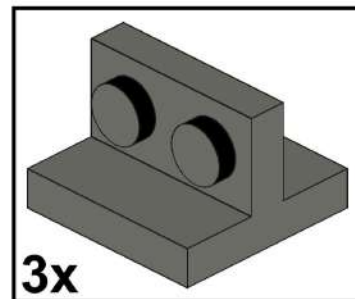
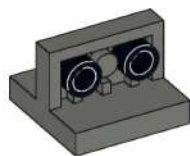
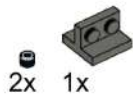

75

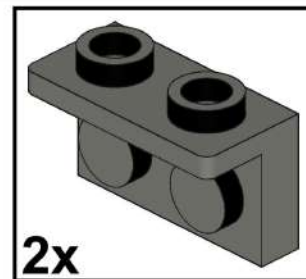

76

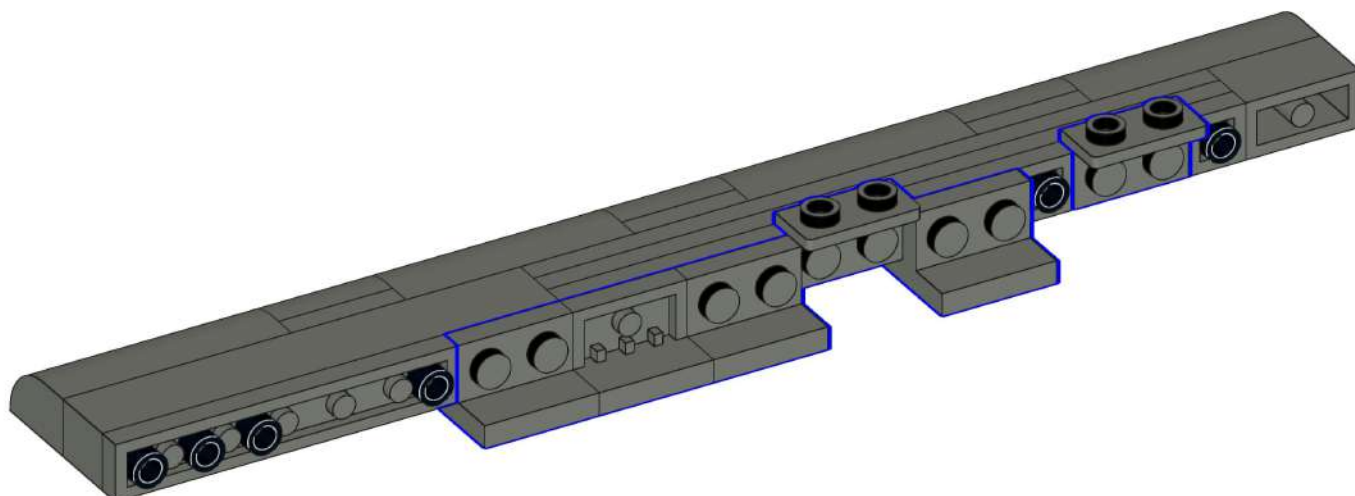

77

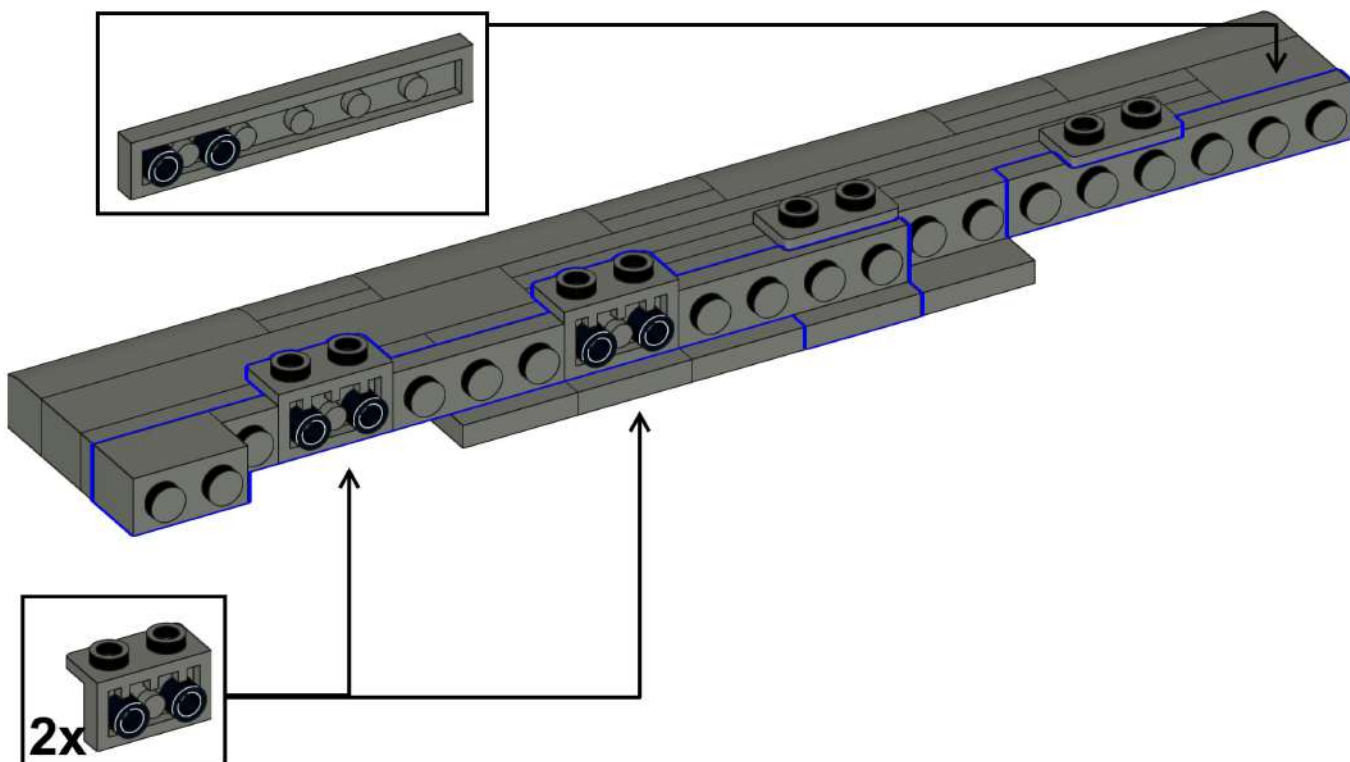
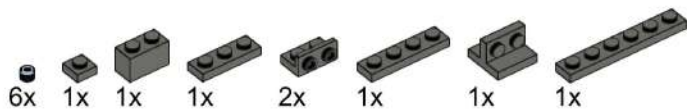

78

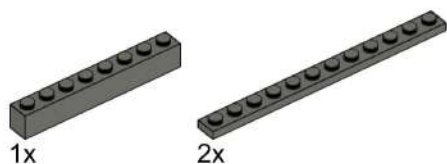

79

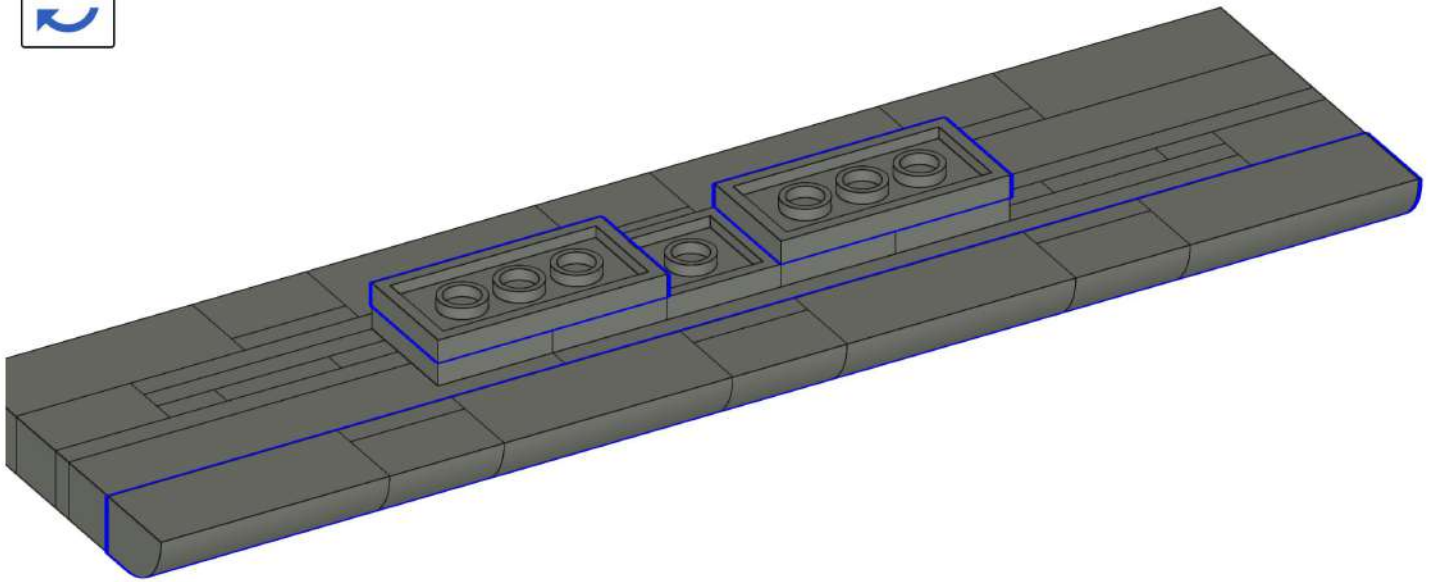
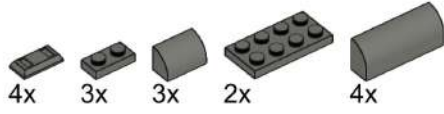

80

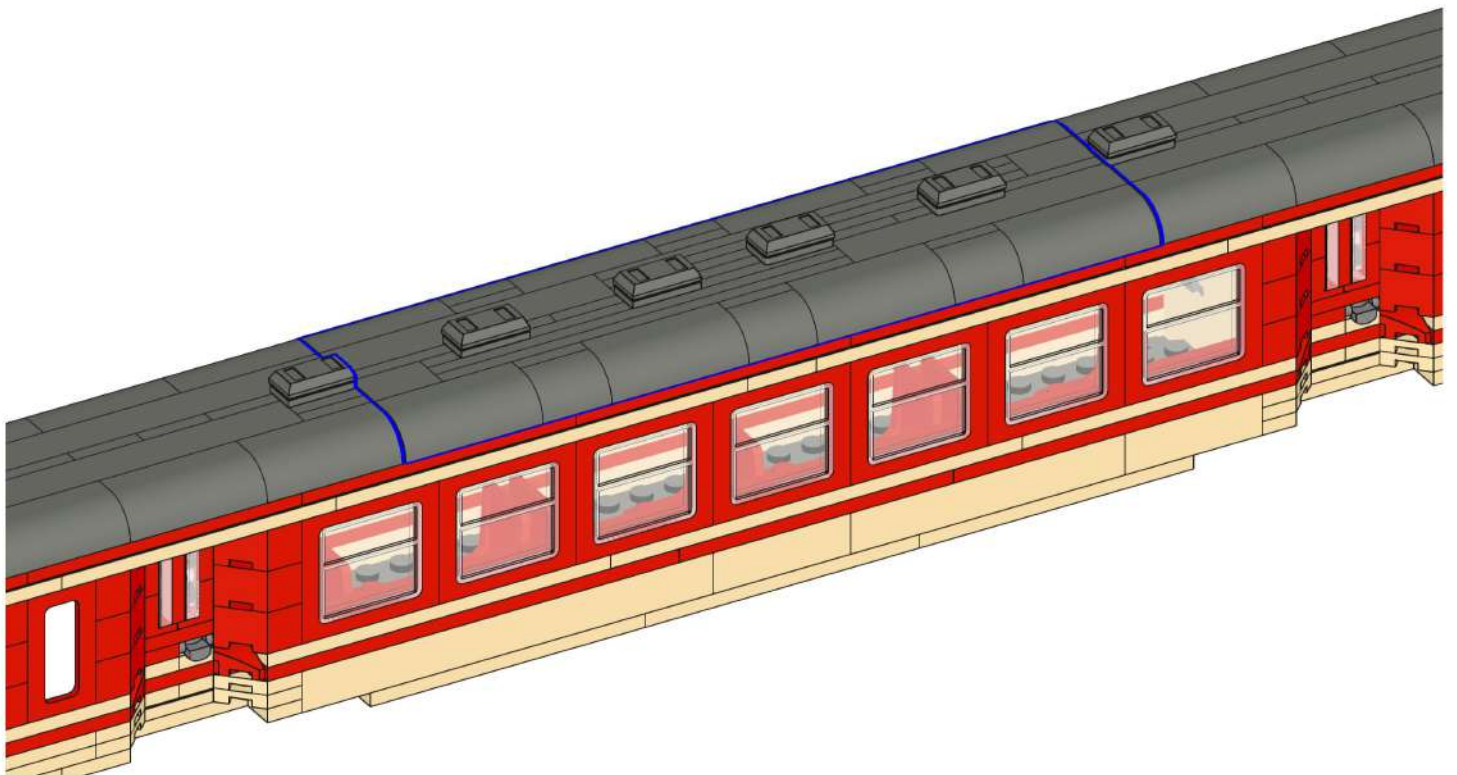

81

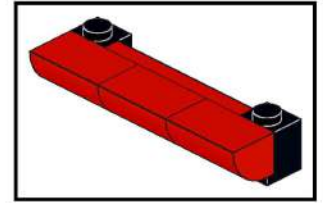
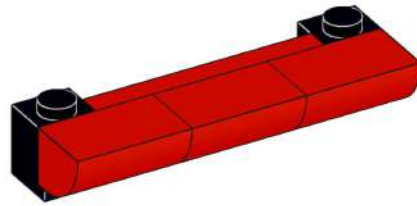
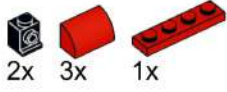

82

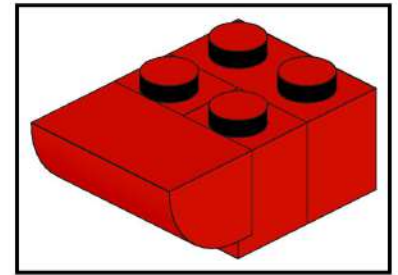
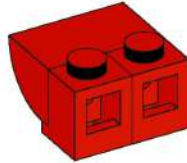
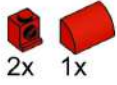

83

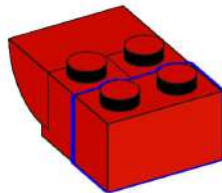

84

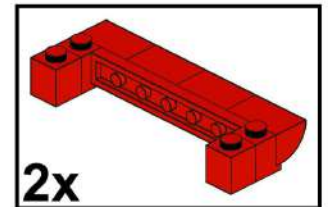
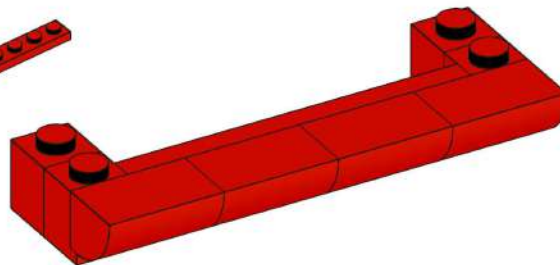
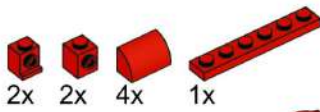

85

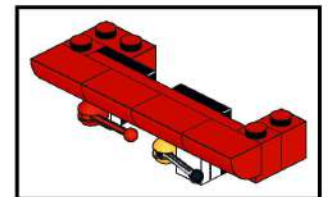
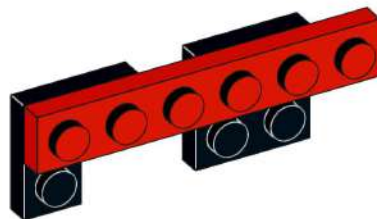
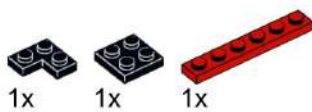

86

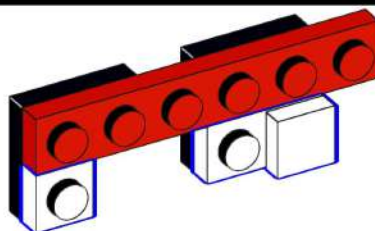
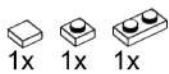

87

1x 1x 1x 1x

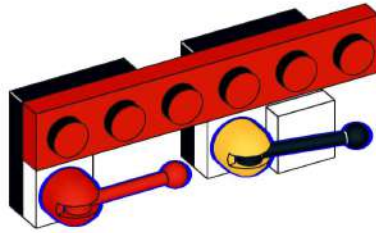

88

2x 1x 4x 1x

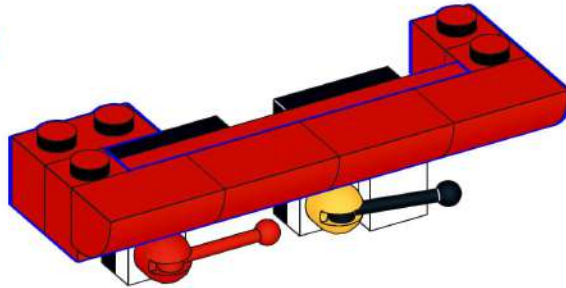

89

1x 1x 1x

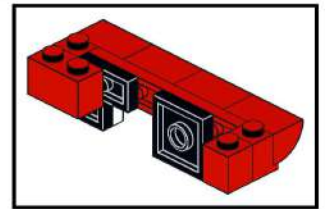
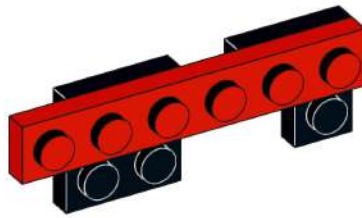

90

1x 1x 1x 1x 1x 1x 1x

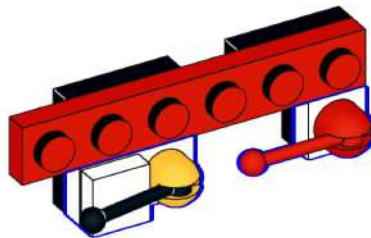

91

2x 1x 4x 1x

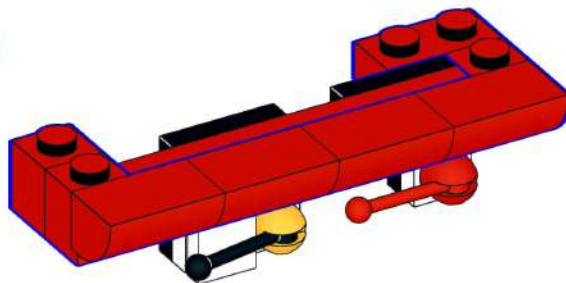

92

4x 1x 1x 1x

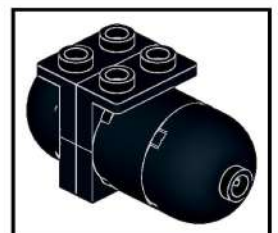
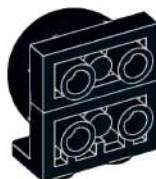

93

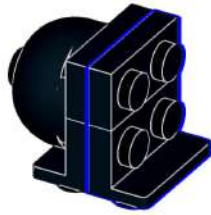

94

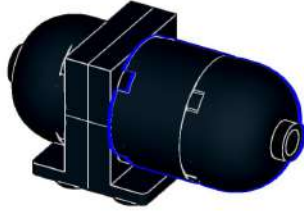

95

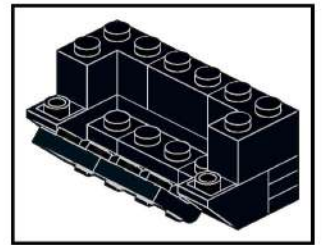
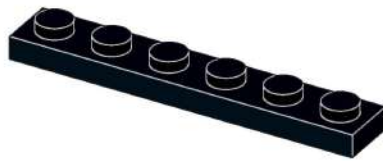

96

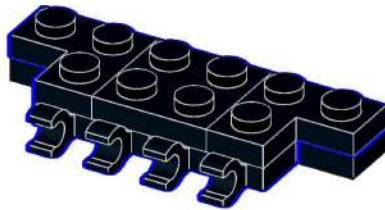

97

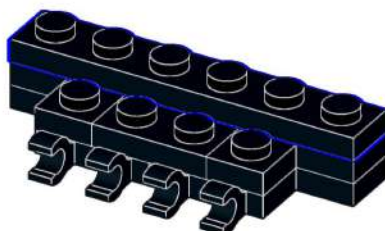

98

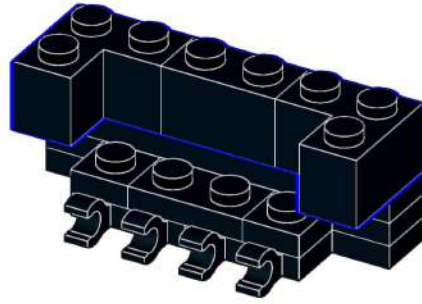
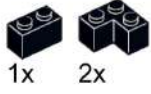

99

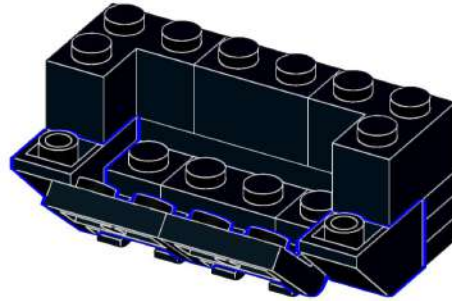

100

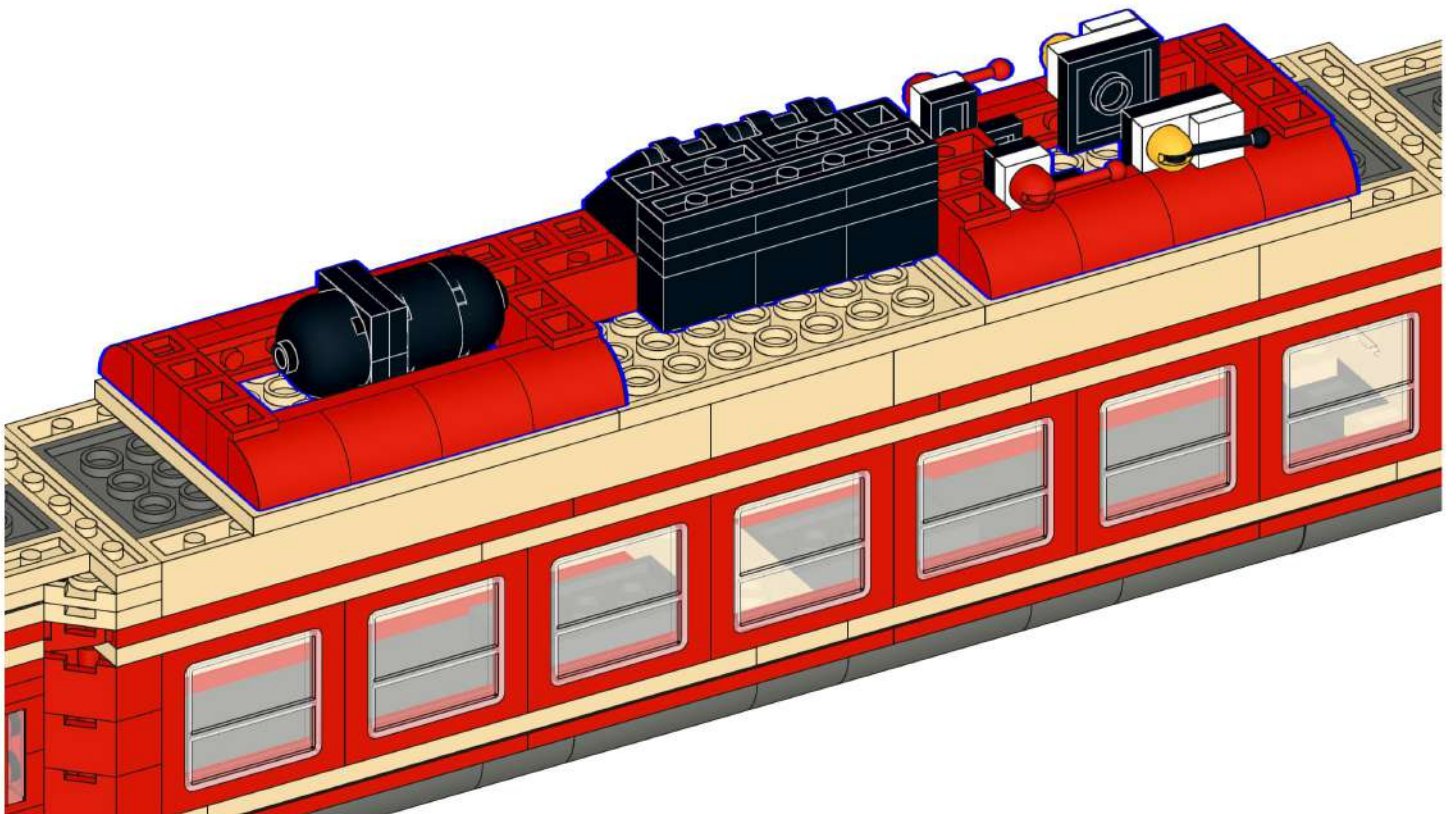

101

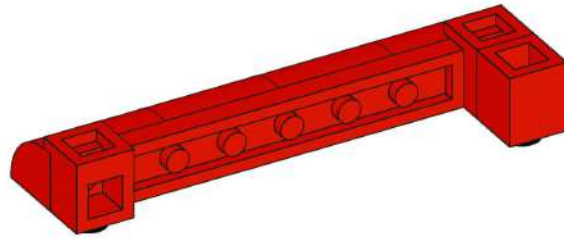
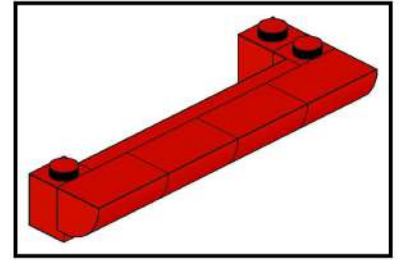
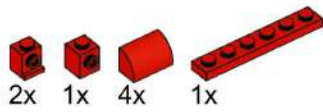

102



103

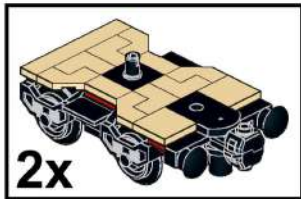
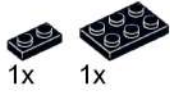

104

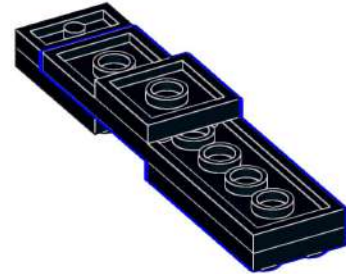

105

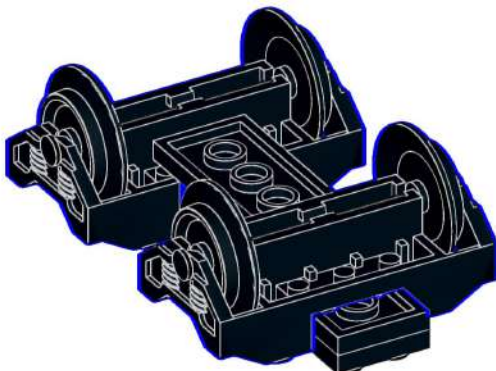
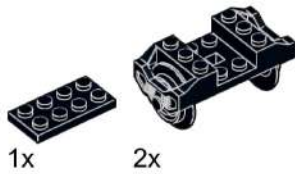

106

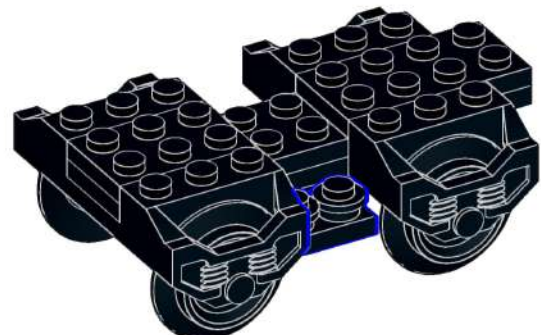
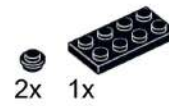

107

2x

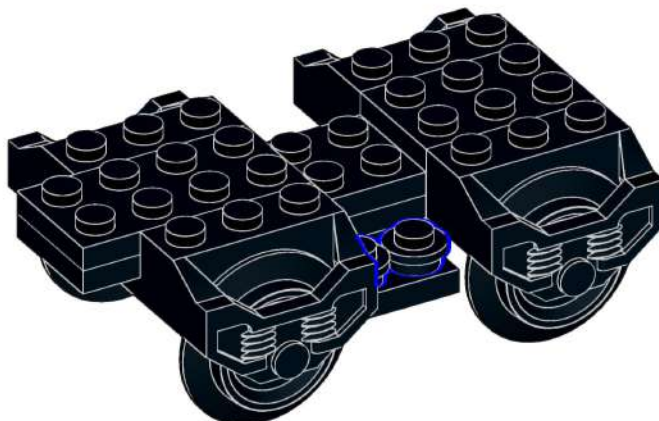

108

2x 2x 2x

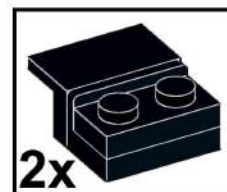
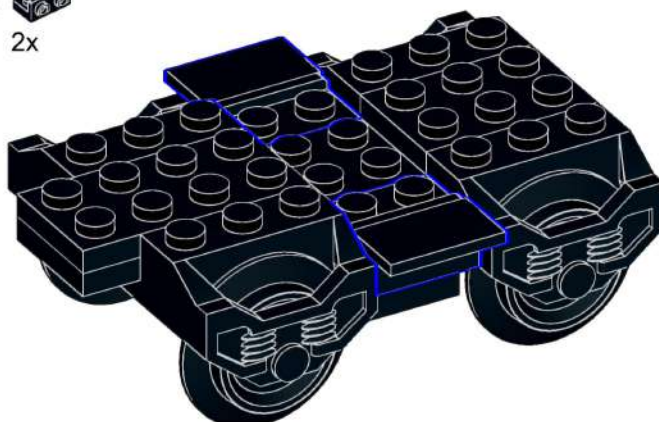

109

1x 1x

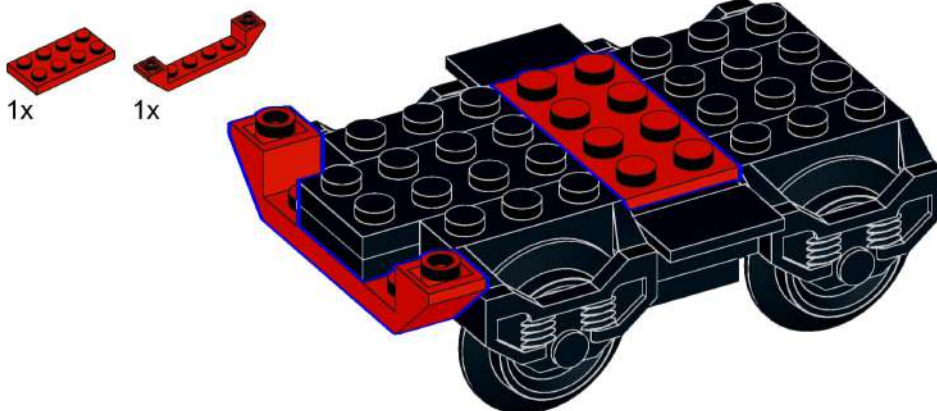

110

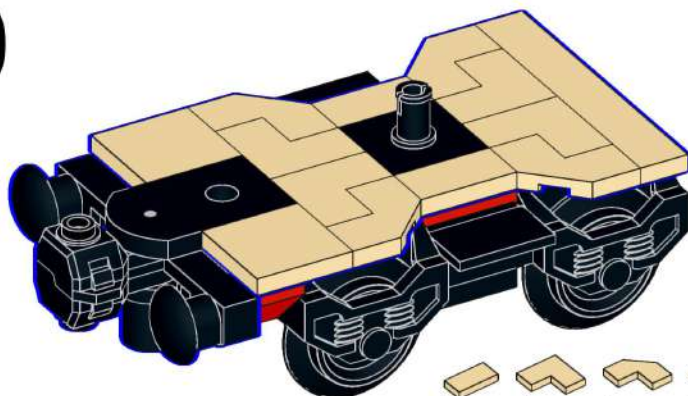

2x 4x 4x 2x 1x 1x 1x



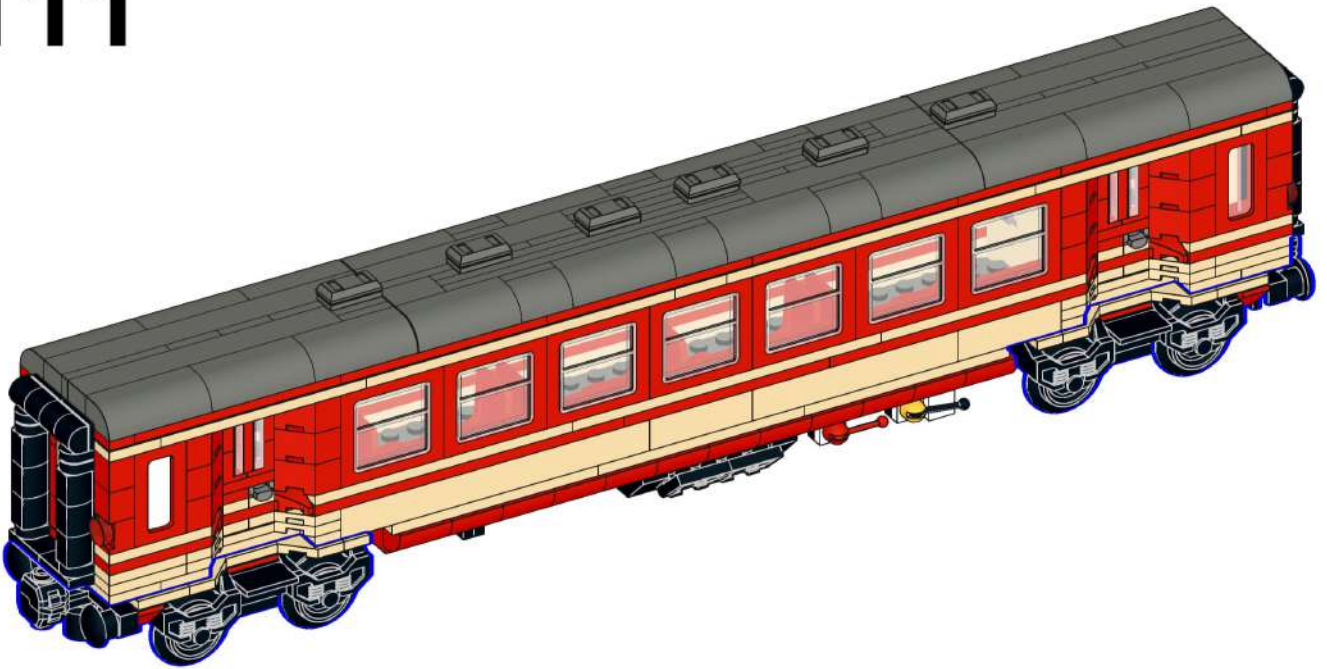

- | | | | | | | | |
|-----|--|--|-----|----|-----|--|-----|
| 50x | | | | 2x | | | |
| 4x | | | 2x | | 16x | | 2x |
| 8x | | | 2x | | 6x | | 20x |
| 4x | | | 1x | | 6x | | |
| 8x | | | 2x | 4x | | | 2x |
| 2x | | | 12x | | 6x | | |
| 2x | | | 1x | | 6x | | 2x |
| 2x | | | 2x | | 2x | | |
| 8x | | | 2x | | 2x | | 2x |
| 8x | | | 2x | | 8x | | |
| 4x | | | 6x | | 11x | | 4x |
| | | | 2x | | 2x | | |
| | | | 8x | | 2x | | |

